

MATHEMATICS

QUESTION BANK

for

CLASS – X

**CHAPTER WISE COVERAGE IN THE FORM
MCQ WORKSHEETS AND PRACTICE QUESTIONS**

Prepared by

M. S. KUMARSWAMY, TGT(MATHS)

M. Sc. Gold Medallist (Elect.), B. Ed.

Kendriya Vidyalaya GaCHIBOWLI

ISAMPAL
DEPUTY COMMISSIONER



केन्द्रीय विद्यालय संगठन, क्षेत्रीय कार्यालय,
के. कामराज मार्ग, बेंगलूर-560 042
KENDRIYA VIDYALAYA SANGATHAN
REGIONAL OFFICE
K. KAMARAJA ROAD, BANGALORE- 560042

F. DO-DC./2013-KVS(BGR)

Dated:05.09.2013

Dear Shri M.S.Kumarswamy,

It has been brought to my notice the good work done by you with regard to making question bank and worksheets for classes VI to X in Mathematics. I am pleased to look at your good work. Mathematics is one discipline which unfortunately and wrongly perceived as a phobia. May be lack of motivation from teachers and inadequate study habits of students is responsible for this state of affairs. Your work in this regard assumes a great significance. I hope your own students as well as students of other Vidyalayas will benefit by your venture. You may mail the material to all the Kendriya Vidyalayas of the region for their benefit. Keep up the good work.

May God bless!

Yours sincerely,

(Isampal)

Shri M.S.Kumarswamy
TGT (Maths)
Kendriya Vidyalaya
Donimalai

Copy to: the principals, Kendriya Vidyalayas, Bangalore Region with instructions to make use of the materials prepared by Mr. M.S.Kumarswamy being forwarded separately.

DEDICATED
TO
MY FATHER
LATE SHRI. M. S. MALLAYYA

INDEX

S. No.	Chapter	Page No.
	SYLLABUS	1 – 3
1	REAL NUMBERS	
	MCQ Worksheets – I to V	6 – 10
	PRACTICE QUESTIONS	11 – 16
2	POLYNOMIALS	
	MCQ Worksheets – I to IV	20 – 23
	PRACTICE QUESTIONS	24 – 31
3	LINEAR EQUATION IN TWO VARIABLES	
	MCQ Worksheets – I to III	35 – 39
	PRACTICE QUESTIONS	38 – 52
4	QUADRATIC EQUATIONS	
	MCQ Worksheets – I to IV	55 – 58
	Practice Questions	59 – 71
5	ARITHMETIC PROGRESSION	
	MCQ Worksheets – I to IV	74 – 78
	Practice Questions	79 – 86
6	TRIANGLES	
	MCQ Worksheets – I to III	89 – 93
	PRACTICE QUESTIONS	94 – 102
7	COORDINATE GEOMETRY	
	MCQ Worksheets – I to IV	105 – 109
	Practice Questions	110 – 121
8	TRIGONOMETRY	
	MCQ Worksheets – I – IV	125 – 129
	PRACTICE QUESTIONS	130 – 136
9	SOME APPLICATIONS TO TRIGONOMETRY	
	MCQ Worksheets – I to III	139 – 141
	Practice Questions	142 – 146
10	CIRCLES	
	MCQ Worksheets – I to III	151 – 156
	Practice Questions	157 – 165
11	CONSTRUCTIONS	
	MCQ Worksheet – I	169 – 170
	Practice Questions	171 – 172
12	AREAS RELATED TO CIRCLES	
	MCQ Worksheets – I to IV	174 – 178
	Practice Questions	179 – 192
13	SURFACE AREAS AND VOLUMES	
	MCQ Worksheets – I - VII	195 – 202
	Practice Questions	203 – 210
14	STATISTICS	
	MCQ Worksheets – I to V	214 – 219
	PRACTICE QUESTIONS	220 – 229
15	PROBABILITY	
	MCQ Worksheets – I – V	232 – 239
	Practice Questions	240 – 258

SYLLABUS
Course Structure
Class X

First Term	Marks : 80
UNITS	MARKS
I NUMBER SYSTEM	06
II ALGEBRA	20
III COORDINATE GEOMETRY	06
IV GEOMETRY	15
V TRIGONOMETRY	12
VI MENSURATION	10
VII STATISTICS AND PROBABILITY	11
TOTAL THEORY	80

UNIT I : NUMBER SYSTEMS

1. REAL NUMBERS

(15) Periods

Euclid's division lemma, Fundamental Theorem of Arithmetic - statements after reviewing work done earlier and after illustrating and motivating through examples, Proofs of results - irrationality of $\sqrt{2}, \sqrt{3}, \sqrt{5}$ decimal expansions of rational numbers in terms of terminating/non-terminating recurring decimals.

UNIT II : ALGEBRA

1. POLYNOMIALS

(7) Periods

Zeros of a polynomial. Relationship between zeros and coefficients of quadratic polynomials. Statement and simple problems on division algorithm for polynomials with real coefficients.

2. PAIR OF LINEAR EQUATIONS IN TWO VARIABLES

(15) Periods

Pair of linear equations in two variables and their graphical solution. Geometric representation of different possibilities of solutions/inconsistency.

Algebraic conditions for number of solutions. Solution of pair of linear equations in two variables algebraically - by substitution, by elimination and by cross multiplication. Simple situational problems must be included. Simple problems on equations reducible to linear equations may be included.

3. QUADRATIC EQUATIONS

(15) Periods

Standard form of a quadratic equation $ax^2 + bx + c = 0$, ($a \neq 0$). Solution of the quadratic equations (only real roots) by factorization and by using quadratic formula. Relationship between discriminant and nature of roots. Problems related to day to day activities to be incorporated. Situational problems based on quadratic equations related to day to day activities to be incorporated.

4. ARITHMETIC PROGRESSIONS

(8) Periods

Motivation for studying AP. Derivation of standard results of finding the n^{th} term and sum of first n terms and their application in solving daily life problems.

UNIT III : COORDINATE GEOMETRY

1. LINES (In two-dimensions)

(14) Periods

Review the concepts of coordinate geometry done earlier including graphs of linear equations. Distance between two points and section formula (internal). Area of a triangle.

UNIT IV : GEOMETRY

1. TRIANGLES

(15) Periods

Definitions, examples, counter examples of similar triangles.

1. (Prove) If a line is drawn parallel to one side of a triangle to intersect the other two sides in distinct points, the other two sides are divided in the same ratio.
2. (Motivate) If a line divides two sides of a triangle in the same ratio, the line is parallel to the third side.
3. (Motivate) If in two triangles, the corresponding angles are equal, their corresponding sides are proportional and the triangles are similar.
4. (Motivate) If the corresponding sides of two triangles are proportional, their corresponding angles are equal and the two triangles are similar.
5. (Motivate) If one angle of a triangle is equal to one angle of another triangle and the sides including these angles are proportional, the two triangles are similar.
6. (Motivate) If a perpendicular is drawn from the vertex of the right angle of a right triangle to the hypotenuse, the triangles on each side of the perpendicular are similar to the whole triangle and to each other.
7. (Prove) The ratio of the areas of two similar triangles is equal to the ratio of the squares on their corresponding sides.
8. (Prove) In a right triangle, the square on the hypotenuse is equal to the sum of the squares on the other two sides.
9. (Prove) In a triangle, if the square on one side is equal to sum of the squares on the other two sides, the angles opposite to the first side is a right triangle.

2. CIRCLES

(8) Periods

Tangents to a circle motivated by chords drawn from points coming closer and closer to the point.

1. (Prove) The tangent at any point of a circle is perpendicular to the radius through the point of contact.
2. (Prove) The lengths of tangents drawn from an external point to circle are equal.

3. CONSTRUCTIONS

(8) Periods

1. Division of a line segment in a given ratio (internally)
2. Tangent to a circle from a point outside it.
3. Construction of a triangle similar to a given triangle.

UNIT V : TRIGONOMETRY

1. INTRODUCTION TO TRIGONOMETRY

(10) Periods

Trigonometric ratios of an acute angle of a right-angled triangle. Proof of their existence (well defined); motivate the ratios, whichever are defined at 0° & 90° . Values (with proofs) of the trigonometric ratios of 30° , 45° & 60° . Relationships between the ratios.

2. TRIGONOMETRIC IDENTITIES

(15) Periods

Proof and applications of the identity $\sin^2 A + \cos^2 A = 1$. Only simple identities to be given. Trigonometric ratios of complementary angles.

3. HEIGHTS AND DISTANCES

(8) Periods

Simple and believable problems on heights and distances. Problems should not involve more than two right triangles. Angles of elevation / depression should be only 30° , 45° & 60°

UNIT VI : MENSURATION

1. AREAS RELATED TO CIRCLES

(12) Periods

Motivate the area of a circle; area of sectors and segments of a circle. Problems based on areas and perimeter / circumference of the above said plane figures. (In calculating area of segment of a circle, problems should be restricted to central angle of 60° , 90° & 120° only. Plane figures involving triangles, simple quadrilaterals and circle should be taken.)

2. SURFACE AREAS AND VOLUMES

(12) Periods

(i) Problems on finding surface areas and volumes of combinations of any two of the following: cubes, cuboids, spheres, hemispheres and right circular cylinders/cones. Frustum of a cone.

(ii) Problems involving converting one type of metallic solid into another and other mixed problems. (Problems with combination of not more than two different solids be taken.)

UNIT VII : STATISTICS AND PROBABILITY

1. STATISTICS

(18) Periods

Mean, median and mode of grouped data (bimodal situation to be avoided). Cumulative frequency graph.

2. PROBABILITY

(10) Periods

Classical definition of probability. Connection with probability as given in Class IX. Simple problems on single events, not using set notation.

INTERNAL ASSESSMENT

20 Marks

• Pen Paper Test and Multiple Assessment (5+5)

10 Marks

• Portfolio

05 Marks

• Lab Practical (Lab activities to be done from the prescribed books)

05 Marks

CLASS X : CHAPTER - 1 REAL NUMBERS

IMPORTANT FORMULAS & CONCEPTS

EUCLID'S DIVISION LEMMA

Given positive integers a and b , there exist unique integers q and r satisfying $a = bq + r$, where $0 \leq r < b$.

Here we call 'a' as dividend, 'b' as divisor, 'q' as quotient and 'r' as remainder.

\therefore Dividend = (Divisor x Quotient) + Remainder

If in Euclid's lemma $r = 0$ then b would be HCF of 'a' and 'b'.

NATURAL NUMBERS

Counting numbers are called natural numbers i.e. 1, 2, 3, 4, 5, are natural numbers.

WHOLE NUMBERS

All counting numbers/natural numbers along with 0 are called whole numbers i.e. 0, 1, 2, 3, 4, 5 are whole numbers.

INTEGERS

All natural numbers, negative of natural numbers and 0, together are called integers. i.e.

..... - 3, - 2, - 1, 0, 1, 2, 3, 4, are integers.

ALGORITHM

An **algorithm** is a series of well defined steps which gives a procedure for solving a type of problem.

LEMMA

A **lemma** is a proven statement used for proving another statement.

EUCLID'S DIVISION ALGORITHM

Euclid's division algorithm is a technique to compute the Highest Common Factor (HCF) of two given positive integers. Recall that the HCF of two positive integers a and b is the largest positive integer d that divides both a and b .

To obtain the HCF of two positive integers, say c and d , with $c > d$, follow the steps below:

Step 1 : Apply Euclid's division lemma, to c and d . So, we find whole numbers, q and r such that $c = dq + r$, $0 \leq r < d$.

Step 2 : If $r = 0$, d is the HCF of c and d . If $r \neq 0$ apply the division lemma to d and r .

Step 3 : Continue the process till the remainder is zero. The divisor at this stage will be the required HCF.

This algorithm works because $\text{HCF}(c, d) = \text{HCF}(d, r)$ where the symbol $\text{HCF}(c, d)$ denotes the HCF of c and d , etc.

The Fundamental Theorem of Arithmetic

Every composite number can be expressed (factorised) as a product of primes, and this factorisation is unique, apart from the order in which the prime factors occur.

The prime factorisation of a natural number is unique, except for the order of its factors.

- ❖ HCF is the highest common factor also known as GCD i.e. greatest common divisor.
- ❖ LCM of two numbers is their least common multiple.
- ❖ Property of HCF and LCM of two positive integers 'a' and 'b':

- $HCF(a,b) \times LCM(a,b) = a \times b$
- $LCM(a,b) = \frac{a \times b}{HCF(a,b)}$
- $HCF(a,b) = \frac{a \times b}{LCM(a,b)}$

PRIME FACTORISATION METHOD TO FIND HCF AND LCM

HCF(a, b) = Product of the smallest power of each common prime factor in the numbers.

LCM(a, b) = Product of the greatest power of each prime factor, involved in the numbers.

RATIONAL NUMBERS

The number in the form of $\frac{p}{q}$ where 'p' and 'q' are integers and $q \neq 0$, e.g. $\frac{2}{3}, \frac{3}{5}, \frac{5}{7}, \dots$

Every rational number can be expressed in decimal form and the decimal form will be either terminating or non-terminating repeating. e.g. $\frac{5}{2} = 2.5$ (Terminating), $\frac{2}{3} = 0.66666\dots$ or $0.\bar{6}$ (Non-terminating repeating).

IRRATIONAL NUMBERS

The numbers which are not rational are called irrational numbers. e.g. $\sqrt{2}, \sqrt{3}, \sqrt{5}, \dots$

- ❖ Let p be a prime number. If p divides a^2 , then p divides a , where a is a positive integer.
- ❖ If p is a positive integer which is not a perfect square, then \sqrt{p} is an irrational, e.g. $\sqrt{2}, \sqrt{5}, \sqrt{6}, \sqrt{8}, \dots$
- ❖ If p is prime, then \sqrt{p} is also an irrational.

RATIONAL NUMBERS AND THEIR DECIMAL EXPANSIONS

- Let x be a rational number whose decimal expansion terminates. Then x can be expressed in the form $\frac{p}{q}$ where p and q are coprime, and the prime factorisation of q is of the form $2^n 5^m$, where n, m are non-negative integers.
- Let $x = \frac{p}{q}$ be a rational number, such that the prime factorisation of q is of the form $2^n 5^m$, where n, m are non-negative integers. Then x has a decimal expansion which terminates.
- Let $x = \frac{p}{q}$ be a rational number, such that the prime factorisation of q is not of the form $2^n 5^m$, where n, m are non-negative integers. Then, x has a decimal expansion which is non-terminating repeating (recurring).
- ❖ The decimal form of irrational numbers is non-terminating and non-repeating.
- ❖ Those decimals which are non-terminating and non-repeating will be irrational numbers. e.g. $0.20200200020002\dots$ is a non-terminating and non-repeating decimal, so it is irrational.

MCQ WORKSHEET-I
CLASS X : CHAPTER - 1
REAL NUMBERS

1. A rational number between $\frac{3}{5}$ and $\frac{4}{5}$ is:
(a) $\frac{7}{5}$ (b) $\frac{7}{10}$ (c) $\frac{3}{10}$ (d) $\frac{4}{10}$
2. A rational number between $\frac{1}{2}$ and $\frac{3}{4}$ is:
(a) $\frac{2}{5}$ (b) $\frac{5}{8}$ (c) $\frac{4}{3}$ (d) $\frac{1}{4}$
3. Which one of the following is not a rational number:
(a) $\sqrt{2}$ (b) 0 (c) $\sqrt{4}$ (d) $\sqrt{-16}$
4. Which one of the following is an irrational number:
(a) $\sqrt{4}$ (b) $3\sqrt{8}$ (c) $\sqrt{100}$ (d) $-\sqrt{0.64}$
5. $3\frac{3}{8}$ in decimal form is:
(a) 3.35 (b) 3.375 (c) 33.75 (d) 337.5
6. $\frac{5}{6}$ in the decimal form is:
(a) $0.8\bar{3}$ (b) $0.8\bar{33}$ (c) $0.6\bar{3}$ (d) $0.6\bar{33}$
7. Decimal representation of rational number $\frac{8}{27}$ is:
(a) $0.2\bar{96}$ (b) $0.29\bar{6}$ (c) $0.2\bar{9}6$ (d) 0.296
8. $0.6666\dots$ in $\frac{p}{q}$ form is:
(a) $\frac{6}{99}$ (b) $\frac{2}{3}$ (c) $\frac{3}{5}$ (d) $\frac{1}{66}$
9. The value of $(\sqrt{5} + \sqrt{2})(\sqrt{5} - \sqrt{2})$ is:
(a) 10 (b) 7 (c) 3 (d) $\sqrt{3}$
10. $0.\bar{36}$ in $\frac{p}{q}$ form is:
(a) $\frac{6}{99}$ (b) $\frac{2}{3}$ (c) $\frac{3}{5}$ (d) none of these

MCQ WORKSHEET-II
CLASS X : CHAPTER - 1
REAL NUMBERS

1. $\sqrt{5}-3-2$ is
(a) a rational number (b) a natural number (c) equal to zero (d) an irrational number
2. Let $x = \frac{7}{20 \times 25}$ be a rational number. Then x has decimal expansion, which terminates:
(a) after four places of decimal (b) after three places of decimal
(c) after two places of decimal (d) after five places of decimal
3. The decimal expansion of $\frac{63}{72 \times 175}$ is
(a) terminating (b) non-terminating
(c) non termination and repeating (d) an irrational number
4. If HCF and LCM of two numbers are 4 and 9696, then the product of the two numbers is:
(a) 9696 (b) 24242 (c) 38784 (d) 4848
5. $(2 + \sqrt{3} + \sqrt{5})$ is :
(a) a rational number (b) a natural number (c) a integer number (d) an irrational number
6. If $\left(\frac{9}{7}\right)^3 \times \left(\frac{49}{81}\right)^{2x-6} = \left(\frac{7}{9}\right)^9$, the value of x is:
(a) 12 (b) 9 (c) 8 (d) 6
7. The number .211 2111 21111..... is a
(a) terminating decimal (b) non-terminating decimal
(c) non termination and non-repeating decimal (d) none of these
8. If $(m)^n = 32$ where m and n are positive integers, then the value of $(n)^{mn}$ is:
(a) 32 (b) 25 (c) 5^{10} (d) 5^{25}
9. The number $0.\overline{57}$ in the $\frac{p}{q}$ form $q \neq 0$ is
(a) $\frac{19}{35}$ (b) $\frac{57}{99}$ (c) $\frac{57}{95}$ (d) $\frac{19}{30}$
10. The number $0.\overline{57}$ in the $\frac{p}{q}$ form $q \neq 0$ is
(a) $\frac{26}{45}$ (b) $\frac{13}{27}$ (c) $\frac{57}{99}$ (d) $\frac{13}{29}$
11. Any one of the numbers a, a + 2 and a + 4 is a multiple of:
(a) 2 (b) 3 (c) 5 (d) 7
12. If p is a prime number and p divides k^2 , then p divides:
(a) $2k^2$ (b) k (c) 3k (d) none of these

MCQ WORKSHEET-III
CLASS X : CHAPTER - 1
REAL NUMBERS

1. π is
(a) a natural number (b) not a real number
(c) a rational number (d) an irrational number
2. The decimal expansion of π
(a) is terminating (b) is non terminating and recurring
(c) is non terminating and non recurring (d) does not exist.
3. Which of the following is not a rational number?
(a) $\sqrt{6}$ (b) $\sqrt{9}$ (c) $\sqrt{25}$ (d) $\sqrt{36}$
4. Which of the following is a rational number?
(a) $\sqrt{36}$ (b) $\sqrt{12}$ (c) $\sqrt{14}$ (d) $\sqrt{21}$
5. If a and b are positive integers, then $\text{HCF}(a, b) \times \text{LCM}(a, b) =$
(a) $a \times b$ (b) $a + b$ (c) $a - b$ (d) a/b
6. If the HCF of two numbers is 1, then the two numbers are called
(a) composite (b) relatively prime or co-prime
(c) perfect (d) irrational numbers
7. The decimal expansion of $\frac{93}{1500}$ will be
(a) terminating (b) non-terminating (c) non-terminating repeating
(d) non-terminating non-repeating.
8. $\sqrt{3}$ is
(a) a natural number (b) not a real number
(c) a rational number (d) an irrational number
9. The HCF of 52 and 130 is
(a) 52 (b) 130 (c) 26 (d) 13
10. For some integer q, every odd integer is of the form
(a) q (b) $q + 1$ (c) $2q$ (d) none of these
11. For some integer q, every even integer is of the form
(a) q (b) $q + 1$ (c) $2q$ (d) none of these
12. Euclid's division lemma state that for any positive integers a and b, there exist unique integers q and r such that $a = bq + r$ where r must satisfy
(a) $1 < r < b$ (b) $0 < r \leq b$ (c) $0 \leq r < b$ (d) $0 < r < b$

MCQ WORKSHEET-IV
CLASS X : CHAPTER - 1
REAL NUMBERS

1. A is a proven statement used for proving another statement.
(a) axiom (b) theorem (c) lemma (d) algorithm
2. The product of non-zero rational and an irrational number is
(a) always rational (b) always irrational (c) rational or irrational (d) one
3. The HCF of smallest composite number and the smallest prime number is
(a) 0 (b) 1 (c) 2 (d) 3
4. Given that $HCF(1152, 1664) = 128$ the $LCM(1152, 1664)$ is
(a) 14976 (b) 1664 (c) 1152 (d) none of these
5. The HCF of two numbers is 23 and their LCM is 1449. If one of the numbers is 161, then the other number is
(a) 23 (b) 207 (c) 1449 (d) none of these
6. Which one of the following rational number is a non-terminating decimal expansion:
(a) $\frac{33}{50}$ (b) $\frac{66}{180}$ (c) $\frac{6}{15}$ (d) $\frac{41}{1000}$
7. A number when divided by 61 gives 27 quotient and 32 as remainder is
(a) 1679 (b) 1664 (c) 1449 (d) none of these
8. The product of L.C.M and H.C.F. of two numbers is equal to
(a) Sum of numbers (b) Difference of numbers
(c) Product of numbers (d) Quotients of numbers
9. L.C.M. of two co-prime numbers is always
(a) product of numbers (b) sum of numbers
(c) difference of numbers (d) none
10. What is the H.C.F. of two consecutive even numbers
(a) 1 (b) 2 (c) 4 (d) 8
11. What is the H.C.F. of two consecutive odd numbers
(a) 1 (b) 2 (c) 4 (d) 8
12. The missing number in the following factor tree is
(a) 2 (b) 6 (c) 3 (d) 9

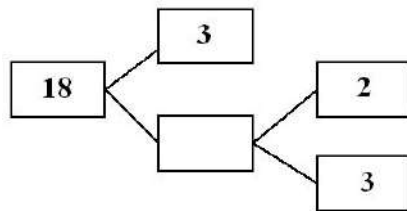

MCQ WORKSHEET-V
CLASS X : CHAPTER - 1
REAL NUMBERS

1. For some integer m , every even integer is of the form
(a) m (b) $m + 1$ (c) $2m$ (d) $2m + 1$
 2. For some integer q , every odd integer is of the form
(a) q (b) $q + 1$ (c) $2q$ (d) $2q + 1$
 3. $n^2 - 1$ is divisible by 8, if n is
(a) an integer (b) a natural number
(c) an odd integer (d) an even integer
 4. If the HCF of 65 and 117 is expressible in the form $65m - 117$, then the value of m is
(a) 4 (b) 2 (c) 1 (d) 3
 5. The largest number which divides 70 and 125, leaving remainders 5 and 8, respectively, is
(a) 13 (b) 65 (c) 875 (d) 1750
 6. If two positive integers a and b are written as $a = x^3y^2$ and $b = xy^3$; x, y are prime numbers, then HCF (a, b) is
(a) xy (b) xy^2 (c) x^3y^3 (d) x^2y^2
 7. If two positive integers p and q can be expressed as $p = ab^2$ and $q = a^3b$; a, b being prime numbers, then LCM (p, q) is
(a) ab (b) a^2b^2 (c) a^3b^2 (d) a^3b^3
 8. The product of a non-zero rational and an irrational number is
(a) always irrational (b) always rational
(c) rational or irrational (d) one
 9. The least number that is divisible by all the numbers from 1 to 10 (both inclusive) is
(a) 10 (b) 100 (c) 504 (d) 2520
 10. The decimal expansion of the rational number $\frac{14587}{1250}$ will terminate after:
(a) one decimal place (b) two decimal places
(c) three decimal places (d) four decimal places
 11. The decimal expansion of the rational number $\frac{33}{2^2 \cdot 5}$ will terminate after
(a) one decimal place (b) two decimal places
(c) three decimal places (d) more than 3 decimal places
-

PRACTICE QUESTIONS
CLASS X : CHAPTER - 1
REAL NUMBERS

1. Write whether every positive integer can be of the form $4q + 2$, where q is an integer. Justify your answer.
2. “The product of two consecutive positive integers is divisible by 2”. Is this statement true or false? Give reasons.
3. “The product of three consecutive positive integers is divisible by 6”. Is this statement true or false”? Justify your answer.
4. Write whether the square of any positive integer can be of the form $3m + 2$, where m is a natural number. Justify your answer.
5. A positive integer is of the form $3q + 1$, q being a natural number. Can you write its square in any form other than $3m + 1$, i.e., $3m$ or $3m + 2$ for some integer m ? Justify your answer.
6. Show that the square of an odd positive integer is of the form $8m + 1$, for some whole number m .
7. Show that the square of any positive integer is either of the form $4q$ or $4q + 1$ for some integer q .
8. Show that cube of any positive integer is of the form $4m$, $4m + 1$ or $4m + 3$, for some integer m .
9. Show that the square of any positive integer cannot be of the form $5q + 2$ or $5q + 3$ for any integer q .
10. Show that the square of any positive integer cannot be of the form $6m + 2$ or $6m + 5$ for any integer m .
11. Show that the square of any odd integer is of the form $4q + 1$, for some integer q .
12. If n is an odd integer, then show that $n^2 - 1$ is divisible by 8.
13. Prove that if x and y are both odd positive integers, then $x^2 + y^2$ is even but not divisible by 4.
14. Show that the square of an odd positive integer can be of the form $6q + 1$ or $6q + 3$ for some integer q .
15. Show that the cube of a positive integer of the form $6q + r$, q is an integer and $r = 0, 1, 2, 3, 4, 5$ is also of the form $6m + r$.
16. Prove that one and only one out of n , $n + 2$ and $n + 4$ is divisible by 3, where n is any positive integer.
17. Prove that one of any three consecutive positive integers must be divisible by 3.
18. For any positive integer n , prove that $n^3 - n$ is divisible by 6.
19. Show that one and only one out of n , $n + 4$, $n + 8$, $n + 12$ and $n + 16$ is divisible by 5, where n is any positive integer.

20. Show that the product of three consecutive natural numbers is divisible by 6.
21. Show that any positive odd integer is of the form $6q + 1$ or $6q + 3$ or $6q + 5$ where $q \in \mathbb{Z}$.
22. Show that any positive even integer is of the form $6q$ or $6q + 2$ or $6q + 4$ where $q \in \mathbb{Z}$.
23. If a and b are two odd positive integers such that $a > b$, then prove that one of the two numbers $\frac{a+b}{2}$ and $\frac{a-b}{2}$ is odd and the other is even.
24. Use Euclid's division lemma to show that the cube of any positive integer is of the form $9m$, $9m + 1$ or $9m + 8$.
25. Using Euclid's division algorithm to show that any positive odd integer is of the form $4q+1$ or $4q+3$, where q is some integer.
26. Use Euclid's division algorithm to find the HCF of 441, 567, 693.
27. Using Euclid's division algorithm, find the largest number that divides 1251, 9377 and 15628 leaving remainders 1, 2 and 3, respectively.
28. Using Euclid's division algorithm, find which of the following pairs of numbers are co-prime:
(i) 231, 396 (ii) 847, 2160
29. Show that 12^n cannot end with the digit 0 or 5 for any natural number n .
30. In a morning walk, three persons step off together and their steps measure 40 cm, 42 cm and 45 cm, respectively. What is the minimum distance each should walk so that each can cover the same distance in complete steps?
31. If $\text{LCM}(480, 672) = 3360$, find $\text{HCF}(480, 672)$.
32. Express 0.69 as a rational number in $\frac{p}{q}$ form.
33. Show that the number of the form 7^n , $n \in \mathbb{N}$ cannot have unit digit zero.
34. Using Euclid's Division Algorithm find the HCF of 9828 and 14742.
35. The numbers 525 and 3000 are both divisible only by 3, 5, 15, 25 and 75. What is $\text{HCF}(525, 3000)$? Justify your answer.
36. Explain why $3 \times 5 \times 7 + 7$ is a composite number.
37. Can two numbers have 18 as their HCF and 380 as their LCM? Give reasons.
38. Without actual division find whether the rational number $\frac{1323}{(6^3 \times 35^2)}$ has a terminating or a non-terminating decimal.

39. Without actually performing the long division, find if $\frac{987}{10500}$ will have terminating or non-terminating (repeating) decimal expansion. Give reasons for your answer.
40. A rational number in its decimal expansion is 327.7081. What can you say about the prime factors of q , when this number is expressed in the form $\frac{p}{q}$? Give reasons.
41. Find the HCF of 81 and 237 and express it as a linear combination of 81 and 237.
42. Find the HCF of 65 and 117 and express it in the form $65m + 117n$.
43. If the HCF of 210 and 55 is expressible in the form of $210x + 55y$, find y .
44. If d is the HCF of 56 and 72, find x, y satisfying $d = 56x + 72y$. Also show that x and y are not unique.
45. Express the HCF of 468 and 222 as $468x + 222y$ where x, y are integers in two different ways.
46. Express the HCF of 210 and 55 as $210x + 55y$ where x, y are integers in two different ways.
47. If the HCF of 408 and 1032 is expressible in the form of $1032m - 408x$, find m .
48. If the HCF of 657 and 963 is expressible in the form of $657n + 963x(-15)$, find n .
49. A sweet seller has 420 kaju burfis and 130 badam burfis she wants to stack them in such a way that each stack has the same number, and they take up the least area of the tray. What is the number of burfis that can be placed in each stack for this purpose?
50. Find the largest number which divides 245 and 1029 leaving remainder 5 in each case.
51. Find the largest number which divides 2053 and 967 and leaves a remainder of 5 and 7 respectively.
52. Two tankers contain 850 litres and 680 litres of kerosene oil respectively. Find the maximum capacity of a container which can measure the kerosene oil of both the tankers when used an exact number of times.
53. In a morning walk, three persons step off together. Their steps measure 80 cm, 85 cm and 90 cm respectively. What is the minimum distance each should walk so that all can cover the same distance in complete steps?
54. Find the least number which when divided by 12, 16, 24 and 36 leaves a remainder 7 in each case.
55. The length, breadth and height of a room are 825 cm, 675 cm and 450 cm respectively. Find the longest tape which can measure the three dimensions of the room exactly.
56. Determine the smallest 3-digit number which is exactly divisible by 6, 8 and 12.
57. Determine the greatest 3-digit number exactly divisible by 8, 10 and 12.
58. The traffic lights at three different road crossings change after every 48 seconds, 72 seconds and 108 seconds respectively. If they change simultaneously at 7 a.m., at what time will they change simultaneously again?

59. Three tankers contain 403 litres, 434 litres and 465 litres of diesel respectively. Find the maximum capacity of a container that can measure the diesel of the three containers exact number of times.
60. Find the least number which when divided by 6, 15 and 18 leave remainder 5 in each case.
61. Find the smallest 4-digit number which is divisible by 18, 24 and 32.
62. Renu purchases two bags of fertiliser of weights 75 kg and 69 kg. Find the maximum value of weight which can measure the weight of the fertiliser exact number of times.
63. In a seminar, the number, the number of participants in Hindi, English and Mathematics are 60, 84 and 108, respectively. Find the minimum number of rooms required if in each room the same number of participants are to be seated and all of them being in the same subject.
64. 144 cartons of Coke cans and 90 cartons of Pepsi cans are to be stacked in a canteen. If each stack is of the same height and is to contain cartons of the same drink, what would be the greatest number of cartons each stack would have?
65. A merchant has 120 litres of oil of one kind, 180 litres of another kind and 240 litres of third kind. He wants to sell the oil by filling the three kinds of oil in tins of equal capacity. What would be the greatest capacity of such a tin?
66. Express each of the following positive integers as the product of its prime factors: (i) 3825 (ii) 5005 (iii) 7429
67. Express each of the following positive integers as the product of its prime factors: (i) 140 (ii) 156 (iii) 234
68. There is circular path around a sports field. Priya takes 18 minutes to drive one round of the field, while Ravish takes 12 minutes for the same. Suppose they both start at the same point and at the same time and go in the same direction. After how many minutes will they meet again at the starting point?
69. In a morning walk, three persons step off together and their steps measure 80 cm, 85 cm and 90 cm, respectively. What is the minimum distance each should walk so that each can cover the same distance in complete steps?
70. A circular field has a circumference of 360 km. Three cyclists start together and can cycle 48, 60 and 72 km a day, round the field. When will they meet again?
71. Find the smallest number which leaves remainders 8 and 12 when divided by 28 and 32 respectively.
72. Find the smallest number which when increased by 17 is exactly divisible by 520 and 468.
73. Find the greatest numbers that will divide 445, 572 and 699 leaving remainders 4, 5 and 6 respectively.
74. Find the greatest number which divides 2011 and 2423 leaving remainders 9 and 5 respectively
75. Find the greatest number which divides 615 and 963 leaving remainder 6 in each case.
76. Find the greatest number which divides 285 and 1249 leaving remainders 9 and 7 respectively.

77. Find the largest possible positive integer that will divide 398, 436, and 542 leaving remainder 7, 11, 15 respectively.
78. If d is the HCF of 30, 72, find the value of x & y satisfying $d = 30x + 72y$.
79. State Euclid's Division Lemma.
80. State the Fundamental theorem of Arithmetic.
81. Given that $\text{HCF}(306, 657) = 9$, find the $\text{LCM}(306, 657)$.
82. Why the number 4^n , where n is a natural number, cannot end with 0?
83. Why is $5 \times 7 \times 11 + 7$ is a composite number?
84. Explain why $7 \times 11 + 13 + 13$ and $7 \times 6 \times 5 \times 4 \times 3 \times 2 \times 1 + 5$ are composite numbers.
85. In a school there are two sections – section A and section B of class X. There are 32 students in section A and 36 students in section B. Determine the minimum number of books required for their class library so that they can be distributed equally among students of section A or section B.
86. Determine the number nearest 110000 but greater than 100000 which is exactly divisible by each of 8, 15 and 21.
87. Three sets of English, Hindi and Mathematics books have to be stacked in such a way that all the books are stored topic wise and the height of each stack is the same. The number of English books is 96, the number of Hindi books is 240 and the number of Mathematics books is 336. Assuming that the books are of the same thickness, determine the number of stacks of English, Hindi and Mathematics books.
88. Using Euclid's division algorithm, find the HCF of 2160 and 3520.
89. Find the HCF and LCM of 144, 180 and 192 by using prime factorization method.
90. Find the missing numbers in the following factorization:

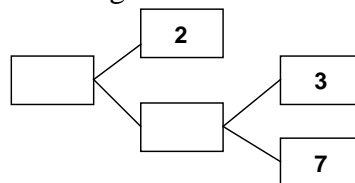

91. Find the HCF and LCM of 17, 23 and 37 by using prime factorization method.
92. If $\text{HCF}(6, a) = 2$ and $\text{LCM}(6, a) = 60$ then find the value of a .
93. If remainder of $\frac{(5m+1)(5m+3)(5m+4)}{5}$ is a natural number then find it.
94. A rational number $\frac{p}{q}$ has a non-terminating repeating decimal expansion. What can you say about q ?

95. If $\frac{278}{2^m m}$ has a terminating decimal expansion and m is a positive integer such that $2 < m < 9$, then find the value of m .
96. Write the condition to be satisfied by q so that a rational number $\frac{p}{q}$ has a terminating expression.
97. If a and b are positive integers. Show that $\sqrt{2}$ always lies between $\frac{a}{b}$ and $\frac{a^2 - 2b^2}{b(a+b)}$.
98. Find two rational number and two irrational number between $\sqrt{2}$ and $\sqrt{3}$.
99. Prove that $5 - 2\sqrt{3}$ is an irrational number.
100. Prove that $15 + 17\sqrt{3}$ is an irrational number.
101. Prove that $\frac{2\sqrt{3}}{5}$ is an irrational number.
102. Prove that $7 + 3\sqrt{2}$ is an irrational number.
103. Prove that $2 + 3\sqrt{5}$ is an irrational number.
104. Prove that $\sqrt{2} + \sqrt{3}$ is an irrational number.
105. Prove that $\sqrt{3} + \sqrt{5}$ is an irrational number.
106. Prove that $7 - 2\sqrt{3}$ is an irrational number.
107. Prove that $3 - \sqrt{5}$ is an irrational number.
108. Prove that $\sqrt{2}$ is an irrational number.
109. Prove that $7 - \sqrt{5}$ is an irrational number
110. Show that there is no positive integer 'n' for which $\sqrt{n-1} + \sqrt{n+1}$ is rational.
-

CLASS X : CHAPTER - 2

POLYNOMIALS

IMPORTANT FORMULAS & CONCEPTS

An algebraic expression of the form $p(x) = a_0 + a_1x + a_2x^2 + a_3x^3 + \dots + a_nx^n$, where $a \neq 0$, is called a polynomial in variable x of degree n .

Here, $a_0, a_1, a_2, a_3, \dots, a_n$ are real numbers and each power of x is a non-negative integer.

e.g. $3x^2 - 5x + 2$ is a polynomial of degree 2.

$3\sqrt{x} + 2$ is not a polynomial.

➤ If $p(x)$ is a polynomial in x , the highest power of x in $p(x)$ is called **the degree of the polynomial** $p(x)$. For example, $4x + 2$ is a polynomial in the variable x of degree 1, $2y^2 - 3y + 4$ is a polynomial in the variable y of degree 2,

- ❖ A polynomial of degree 0 is called a constant polynomial.
- ❖ A polynomial $p(x) = ax + b$ of degree 1 is called a linear polynomial.
- ❖ A polynomial $p(x) = ax^2 + bx + c$ of degree 2 is called a quadratic polynomial.
- ❖ A polynomial $p(x) = ax^3 + bx^2 + cx + d$ of degree 3 is called a cubic polynomial.
- ❖ A polynomial $p(x) = ax^4 + bx^3 + cx^2 + dx + e$ of degree 4 is called a bi-quadratic polynomial.

VALUE OF A POLYNOMIAL AT A GIVEN POINT $x = k$

If $p(x)$ is a polynomial in x , and if k is any real number, then the value obtained by replacing x by k in $p(x)$, is called **the value of $p(x)$ at $x = k$** , and is denoted by $p(k)$.

ZERO OF A POLYNOMIAL

A real number k is said to be a **zero of a polynomial $p(x)$** , if $p(k) = 0$.

- ❖ Geometrically, the zeroes of a polynomial $p(x)$ are precisely the x -coordinates of the points, where the graph of $y = p(x)$ intersects the x -axis.
- ❖ A quadratic polynomial can have at most 2 zeroes and a cubic polynomial can have at most 3 zeroes.
- ❖ In general, a polynomial of degree 'n' has at the most 'n' zeroes.

RELATIONSHIP BETWEEN ZEROES & COEFFICIENTS OF POLYNOMIALS

Type of Polynomial	General form	No. of zeroes	Relationship between zeroes and coefficients
Linear	$ax + b, a \neq 0$	1	$k = -\frac{b}{a}$, i.e. $k = -\frac{\text{Constant term}}{\text{Coefficient of } x}$
Quadratic	$ax^2 + bx + c, a \neq 0$	2	Sum of zeroes $(\alpha + \beta) = -\frac{\text{Coefficient of } x}{\text{Coefficient of } x^2} = -\frac{b}{a}$ Product of zeroes $(\alpha\beta) = \frac{\text{Constant term}}{\text{Coefficient of } x^2} = \frac{c}{a}$
Cubic	$ax^3 + bx^2 + cx + d, a \neq 0$	3	Sum of zeroes $(\alpha + \beta + \gamma) = -\frac{\text{Coefficient of } x^2}{\text{Coefficient of } x^3} = -\frac{b}{a}$ Product of sum of zeroes taken two at a time $(\alpha\beta + \beta\gamma + \gamma\alpha) = \frac{\text{Coefficient of } x}{\text{Coefficient of } x^3} = \frac{c}{a}$ Product of zeroes $(\alpha\beta\gamma) = -\frac{\text{Constant term}}{\text{Coefficient of } x^3} = -\frac{d}{a}$

❖ A quadratic polynomial whose zeroes are α and β is given by $p(x) = x^2 - (\alpha + \beta)x + \alpha\beta$
 i.e. $x^2 - (\text{Sum of zeroes})x + (\text{Product of zeroes})$

❖ A cubic polynomial whose zeroes are α, β and γ is given by

$$p(x) = x^3 - (\alpha + \beta + \gamma)x^2 + (\alpha\beta + \beta\gamma + \gamma\alpha)x - \alpha\beta\gamma$$

The zeroes of a quadratic polynomial $ax^2 + bx + c, a \neq 0$, are precisely the x -coordinates of the points where the parabola representing $y = ax^2 + bx + c$ intersects the x -axis.

In fact, for any quadratic polynomial $ax^2 + bx + c, a \neq 0$, the graph of the corresponding equation $y = ax^2 + bx + c$ has one of the two shapes either open upwards like \cup or open downwards like \cap depending on whether $a > 0$ or $a < 0$. (These curves are called **parabolas**.)

The following three cases can be happen about the graph of quadratic polynomial $ax^2 + bx + c$:

Case (i) : Here, the graph cuts x -axis at two distinct points A and A'. The x -coordinates of A and A' are the **two zeroes** of the quadratic polynomial $ax^2 + bx + c$ in this case

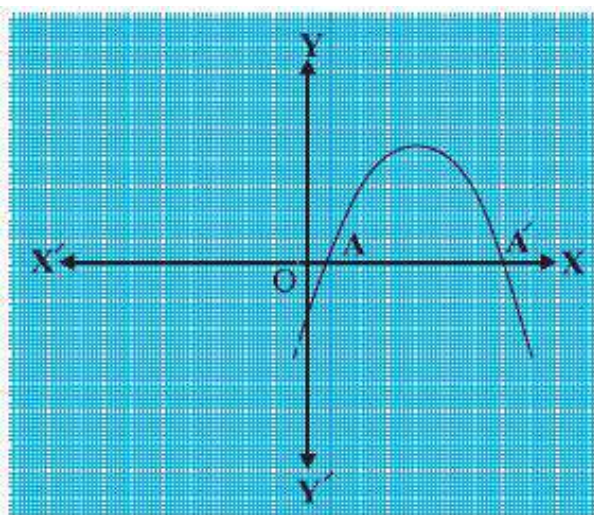

(i)
 $a > 0$

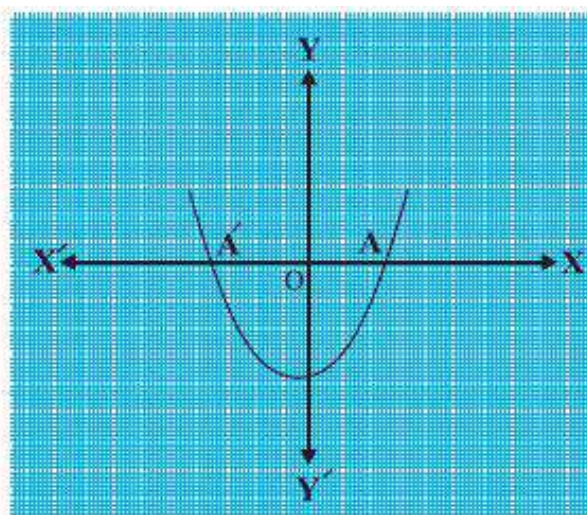

(ii)
 $a < 0$

Case (ii) : Here, the graph cuts the x -axis at exactly one point, i.e., at two coincident points. So, the two points A and A' of Case (i) coincide here to become one point A. The x -coordinate of A is the **only zero** for the quadratic polynomial $ax^2 + bx + c$ in this case.

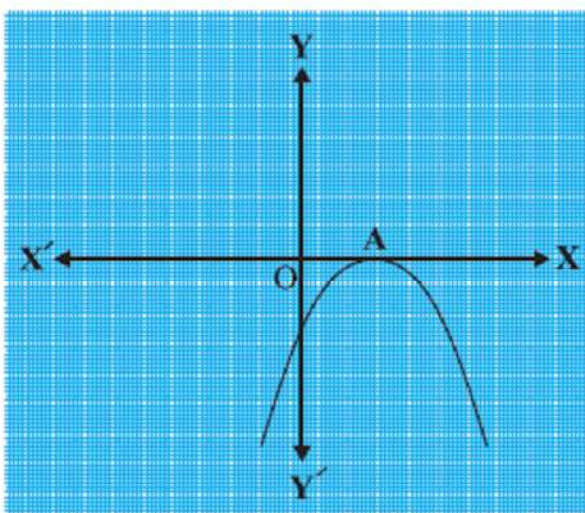

(i)
 $a > 0$

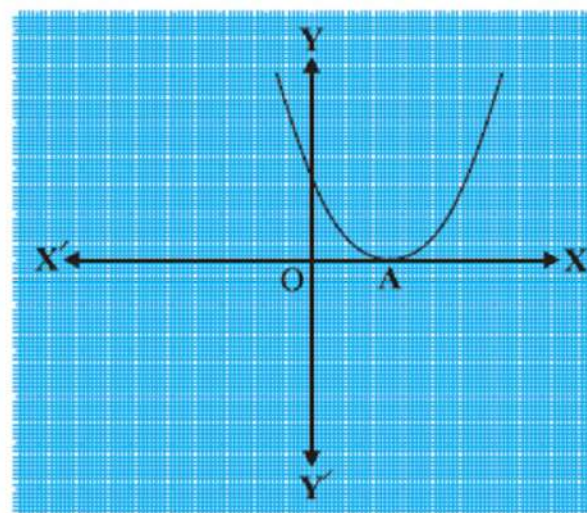

(ii)
 $a < 0$

Case (iii) : Here, the graph is either completely above the x -axis or completely below the x -axis. So, it does not cut the x -axis at any point. So, the quadratic polynomial $ax^2 + bx + c$ has **no zero** in this case.

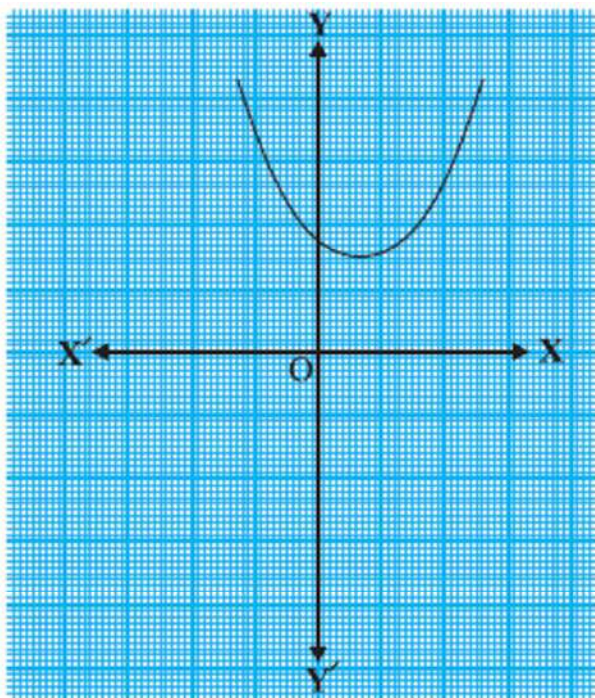

(i)
 $a > 0$

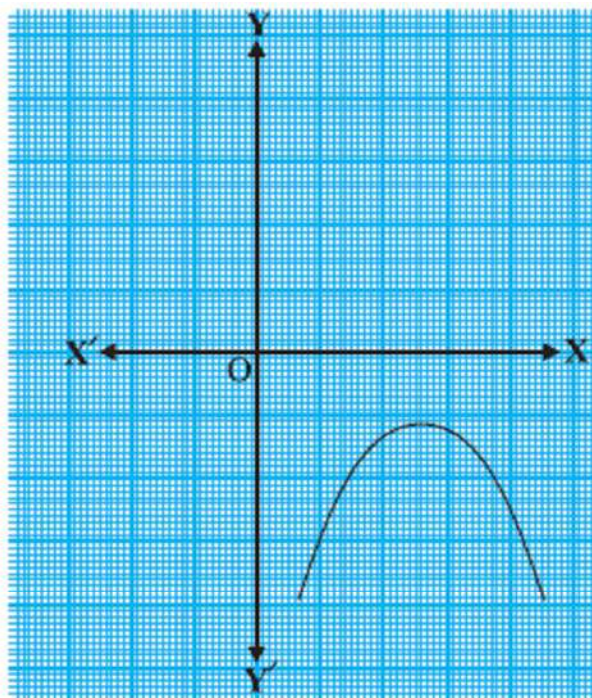

(ii)
 $a < 0$

DIVISION ALGORITHM FOR POLYNOMIALS

If $p(x)$ and $g(x)$ are any two polynomials with $g(x) \neq 0$, then we can find polynomials $q(x)$ and $r(x)$ such that $p(x) = g(x) \times q(x) + r(x)$,
where $r(x) = 0$ or degree of $r(x) <$ degree of $g(x)$.

- ❖ If $r(x) = 0$, then $g(x)$ is a factor of $p(x)$.
- ❖ Dividend = Divisor \times Quotient + Remainder

MCQ WORKSHEET-I
CLASS X : CHAPTER - 2
POLYNOMIALS

1. The value of k for which (-4) is a zero of the polynomial $x^2 - x - (2k + 2)$ is
 (a) 3 (b) 9 (c) 6 (d) -1

2. If the zeroes of the quadratic polynomial $ax^2 + bx + c$, $c \neq 0$ are equal, then

- (a) c and a have opposite sign (b) c and b have opposite sign
 (c) c and a have the same sign (d) c and b have the same sign

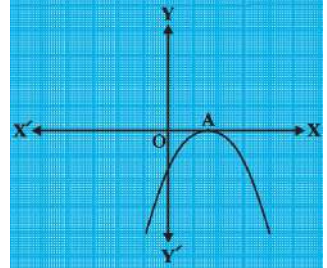

3. The number of zeroes of the polynomial from the graph is

- (a) 0 (b) 1 (c) 2 (d) 3

4. If one of the zero of the quadratic polynomial $x^2 + 3x + k$ is 2, then the value of k is

- (a) 10 (b) -10 (c) 5 (d) -5

5. A quadratic polynomial whose zeroes are -3 and 4 is

- (a) $x^2 - x + 12$ (b) $x^2 + x + 12$ (c) $2x^2 + 2x - 24$. (d) none of the above.

6. The relationship between the zeroes and coefficients of the quadratic polynomial $ax^2 + bx + c$

- is (a) $\alpha + \beta = \frac{c}{a}$ (b) $\alpha + \beta = \frac{-b}{a}$ (c) $\alpha + \beta = \frac{-c}{a}$ (d) $\alpha + \beta = \frac{b}{a}$

7. The zeroes of the polynomial $x^2 + 7x + 10$ are

- (a) 2 and 5 (b) -2 and 5 (c) -2 and -5 (d) 2 and -5

8. The relationship between the zeroes and coefficients of the quadratic polynomial $ax^2 + bx + c$

- is (a) $\alpha . \beta = \frac{c}{a}$ (b) $\alpha . \beta = \frac{-b}{a}$ (c) $\alpha . \beta = \frac{-c}{a}$ (d) $\alpha . \beta = \frac{b}{a}$

9. The zeroes of the polynomial $x^2 - 3$ are

- (a) 2 and 5 (b) -2 and 5 (c) -2 and -5 (d) none of the above

10. The number of zeroes of the polynomial from the graph is

- (a) 0 (b) 1 (c) 2 (d) 3

11. A quadratic polynomial whose sum and product of zeroes are -3 and 2 is

- (a) $x^2 - 3x + 2$ (b) $x^2 + 3x + 2$ (c) $x^2 + 2x - 3$. (d) $x^2 + 2x + 3$.

12. The zeroes of the quadratic polynomial $x^2 + kx + k$, $k \neq 0$,

- (a) cannot both be positive (b) cannot both be negative
 (c) are always unequal (d) are always equal

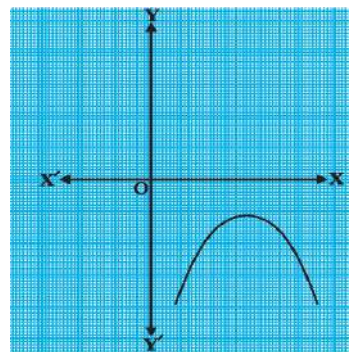

.....

MCQ WORKSHEET-II
CLASS X : CHAPTER - 2
POLYNOMIALS

1. If α, β are the zeroes of the polynomials $f(x) = x^2 + x + 1$, then $\frac{1}{\alpha} + \frac{1}{\beta}$
(a) 0 (b) 1 (c) -1 (d) none of these
2. If one of the zero of the polynomial $f(x) = (k^2 + 4)x^2 + 13x + 4k$ is reciprocal of the other then $k =$
(a) 2 (b) 1 (c) -1 (d) -2
3. If α, β are the zeroes of the polynomials $f(x) = 4x^2 + 3x + 7$, then $\frac{1}{\alpha} + \frac{1}{\beta}$
(a) $\frac{7}{3}$ (b) $\frac{-7}{3}$ (c) $\frac{3}{7}$ (d) $\frac{-3}{7}$
4. If the sum of the zeroes of the polynomial $f(x) = 2x^3 - 3kx^2 + 4x - 5$ is 6, then value of k is
(a) 2 (b) 4 (c) -2 (d) -4
5. The zeroes of a polynomial $p(x)$ are precisely the x -coordinates of the points, where the graph of $y = p(x)$ intersects the
(a) x - axis (b) y - axis (c) origin (d) none of the above
6. If α, β are the zeroes of the polynomials $f(x) = x^2 - p(x + 1) - c$, then $(\alpha + 1)(\beta + 1) =$
(a) $c - 1$ (b) $1 - c$ (c) c (d) $1 + c$
7. A quadratic polynomial can have at most zeroes
(a) 0 (b) 1 (c) 2 (d) 3
8. A cubic polynomial can have at most zeroes.
(a) 0 (b) 1 (c) 2 (d) 3
9. Which are the zeroes of $p(x) = x^2 - 1$:
(a) 1, -1 (b) -1, 2 (c) -2, 2 (d) -3, 3
10. Which are the zeroes of $p(x) = (x - 1)(x - 2)$:
(a) 1, -2 (b) -1, 2 (c) 1, 2 (d) -1, -2
11. Which of the following is a polynomial?
(a) $x^2 - 5x + 3$
(b) $\sqrt{x} + \frac{1}{\sqrt{x}}$
(c) $x^{3/2} - x + x^{1/2}$
(d) $x^{1/2} + x + 10$
12. Which of the following is not a polynomial?
(a) $\sqrt{3}x^2 - 2\sqrt{3}x + 3$
(b) $\frac{3}{2}x^3 - 5x^2 - \frac{1}{\sqrt{2}}x - 1$
(c) $x + \frac{1}{x}$
(d) $5x^2 - 3x + \sqrt{2}$

MCQ WORKSHEET-III
CLASS X : CHAPTER - 2
POLYNOMIALS

1. If α, β are the zeroes of the polynomials $f(x) = x^2 + 5x + 8$, then $\alpha + \beta$
(a) 5 (b) -5 (c) 8 (d) none of these
 2. If α, β are the zeroes of the polynomials $f(x) = x^2 + 5x + 8$, then $\alpha.\beta$
(a) 0 (b) 1 (c) -1 (d) none of these
 3. On dividing $x^3 + 3x^2 + 3x + 1$ by $x + \pi$ we get remainder:
(a) $-\pi^3 + 3\pi^2 - 3\pi + 1$
(b) $\pi^3 - 3\pi^2 + 3\pi + 1$
(c) $-\pi^3 - 3\pi^2 - 3\pi - 1$
(d) $-\pi^3 + 3\pi^2 - 3\pi - 1$
 4. The zero of $p(x) = 9x + 4$ is:
(a) $\frac{4}{9}$ (b) $\frac{9}{4}$ (c) $-\frac{4}{9}$ (d) $-\frac{9}{4}$
 5. On dividing $x^3 + 3x^2 + 3x + 1$ by $5 + 2x$ we get remainder:
(a) $\frac{8}{27}$ (b) $-\frac{8}{27}$ (c) $-\frac{27}{8}$ (d) $\frac{27}{8}$
 6. A quadratic polynomial whose sum and product of zeroes are -3 and 4 is
(a) $x^2 - 3x + 12$ (b) $x^2 + 3x + 12$ (c) $2x^2 + x - 24$. (d) none of the above.
 7. A quadratic polynomial whose zeroes are $\frac{3}{5}$ and $-\frac{1}{2}$ is
(a) $10x^2 - x - 3$ (b) $10x^2 + x - 3$ (c) $10x^2 - x + 3$ (d) none of the above.
 8. A quadratic polynomial whose sum and product of zeroes are 0 and 5 is
(a) $x^2 - 5$ (b) $x^2 + 5$ (c) $x^2 + x - 5$. (d) none of the above.
 9. A quadratic polynomial whose zeroes are 1 and -3 is
(a) $x^2 - 2x - 3$ (b) $x^2 + 2x - 3$ (c) $x^2 - 2x + 3$ (d) none of the above.
 10. A quadratic polynomial whose sum and product of zeroes are -5 and 6 is
(a) $x^2 - 5x - 6$ (b) $x^2 + 5x - 6$ (c) $x^2 + 5x + 6$ (d) none of the above.
 11. Which are the zeroes of $p(x) = x^2 + 3x - 10$:
(a) 5, -2 (b) -5, 2 (c) -5, -2 (d) none of these
 12. Which are the zeroes of $p(x) = 6x^2 - 7x - 3$:
(a) 5, -2 (b) -5, 2 (c) -5, -2 (d) none of these
 13. Which are the zeroes of $p(x) = x^2 + 7x + 12$:
(a) 4, -3 (b) -4, 3 (c) -4, -3 (d) none of these
-

MCQ WORKSHEET-IV
CLASS X : CHAPTER - 2
POLYNOMIALS

1. The degree of the polynomial whose graph is given below:
(a) 1 (b) 2 (c) ≥ 3 (d) cannot be fixed
2. If the sum of the zeroes of the polynomial $3x^2 - kx + 6$ is 3, then the value of k is:
(a) 3 (b) -3 (c) 6 (d) 9
3. The other two zeroes of the polynomial $x^3 - 8x^2 + 19x - 12$ if its one zeroes is $x = 1$ are:
(a) 3, -4 (b) -3, -4 (c) -3, 4 (d) 3, 4
4. The quadratic polynomial, the sum and product of whose zeroes are -3 and 2 is:
(a) $x^2 - 3x + 2$ (b) $x^2 + 3x - 2$ (c) $x^2 + 3x + 2$ (d) none of the these.
5. The third zero of the polynomial, if the sum and product of whose zeroes are -3 and 2 is:
(a) 7 (b) -7 (c) 14 (d) -14
6. If $\sqrt{\frac{5}{3}}$ and $-\sqrt{\frac{5}{3}}$ are two zeroes of the polynomial $3x^4 + 6x^3 - 2x^2 - 10x - 5$, then its other two zeroes are:
(a) -1, -1 (b) 1, -1 (c) 1, 1 (d) 3, -3
7. If $a - b$, a and $a + b$ are zeroes of the polynomial $x^3 - 3x^2 + x + 1$ the value of $(a + b)$ is
(a) $1 \pm \sqrt{2}$ (b) $-1 + \sqrt{2}$ (c) $-1 - \sqrt{2}$ (d) 3
8. A real numbers a is called a zero of the polynomial $f(x)$, then
(a) $f(a) = -1$ (b) $f(a) = 1$ (c) $f(a) = 0$ (d) $f(a) = -2$
9. Which of the following is a polynomial:
(a) $x^2 + \frac{1}{x}$ (b) $2x^2 - 3\sqrt{x} + 1$ (c) $x^2 + x^{-2} + 7$ (d) $3x^2 - 3x + 1$
10. The product and sum of zeroes of the quadratic polynomial $ax^2 + bx + c$ respectively are:
(a) $\frac{b}{a}, \frac{c}{a}$ (b) $\frac{c}{a}, \frac{b}{a}$ (c) $\frac{c}{b}, 1$ (d) $\frac{c}{a}, \frac{-b}{a}$
11. The quadratic polynomial, sum and product of whose zeroes are 1 and -12 respectively is
(a) $x^2 - x - 12$ (b) $x^2 + x - 12$ (c) $x^2 - 12x + 1$ (d) $x^2 - 12x - 1$.
12. If the product of two of the zeroes of the polynomial $2x^3 - 9x^2 + 13x - 6$ is 2, the third zero of the polynomial is:
(a) -1 (b) -2 (c) $\frac{3}{2}$ (d) $-\frac{3}{2}$

PRACTICE QUESTIONS
CLASS X : CHAPTER - 2
POLYNOMIALS

1. If $p(x) = 3x^3 - 2x^2 + 6x - 5$, find $p(2)$.
2. Draw the graph of the polynomial $f(x) = x^2 - 2x - 8$.
3. Draw the graph of the polynomial $f(x) = 3 - 2x - x^2$.
4. Draw the graph of the polynomial $f(x) = -3x^2 + 2x - 1$.
5. Draw the graph of the polynomial $f(x) = x^2 - 6x + 9$.
6. Draw the graph of the polynomial $f(x) = x^3$.
7. Draw the graph of the polynomial $f(x) = x^3 - 4x$.
8. Draw the graph of the polynomial $f(x) = x^3 - 2x^2$.
9. Draw the graph of the polynomial $f(x) = -4x^2 + 4x - 1$.
10. Draw the graph of the polynomial $f(x) = 2x^2 - 4x + 5$.
11. Find the quadratic polynomial whose zeroes are $2 + \sqrt{3}$ and $2 - \sqrt{3}$.
12. Find the quadratic polynomial whose zeroes are $\frac{3 - \sqrt{3}}{5}$ and $\frac{3 + \sqrt{3}}{5}$.
13. Find a quadratic polynomial whose sum and product of zeroes are $\sqrt{2}$ and 3 respectively.
14. Find the zeroes of the polynomial $mx^2 + (m + n)x + n$.
15. If m and n are zeroes of the polynomial $3x^2 + 11x - 4$, find the value of $\frac{m}{n} + \frac{n}{m}$.
16. If a and b are zeroes of the polynomial $x^2 - x - 6$, then find a quadratic polynomial whose zeroes are $(3a + 2b)$ and $(2a + 3b)$.
17. If p and q are zeroes of the polynomial $t^2 - 4t + 3$, show that $\frac{1}{p} + \frac{1}{q} - 2pq + \frac{14}{3} = 0$.
18. If $(x - 6)$ is a factor of $x^3 + ax^2 + bx - b = 0$ and $a - b = 7$, find the values of a and b .
19. If 2 and -3 are the zeroes of the polynomial $x^2 + (a + 1)x + b$, then find the value of a and b .
20. Obtain all zeroes of polynomial $f(x) = 2x^4 + x^3 - 14x^2 - 19x - 6$ if two of its zeroes are -2 and -1 .
21. Find all the zeroes of the polynomial $2x^3 - 4x - x^2 + 2$, if two of its zeroes are $\sqrt{2}$ and $-\sqrt{2}$.
22. Find all the zeroes of the polynomial $x^4 - 3x^3 + 6x - 4$, if two of its zeroes are $\sqrt{2}$ and $-\sqrt{2}$.
23. Find all the zeroes of the polynomial $2x^4 - 9x^3 + 5x^2 + 3x - 1$, if two of its zeroes are $2 + \sqrt{3}$ and $2 - \sqrt{3}$.

24. Find all the zeroes of the polynomial $2x^4 + 7x^3 - 19x^2 - 14x + 30$, if two of its zeroes are $\sqrt{2}$ and $-\sqrt{2}$.
25. Find all the zeroes of the polynomial $x^3 + 3x^2 - 2x - 6$, if two of its zeroes are $\sqrt{2}$ and $-\sqrt{2}$.
26. Find all the zeroes of the polynomial $2x^3 - x^2 - 5x - 2$, if two of its zeroes are -1 and 2 .
27. Find all the zeroes of the polynomial $x^3 + 3x^2 - 5x - 15$, if two of its zeroes are $\sqrt{5}$ and $-\sqrt{5}$.
28. Find all the zeroes of the polynomial $x^3 - 4x^2 - 3x + 12$, if two of its zeroes are $\sqrt{3}$ and $-\sqrt{3}$.
29. Find all the zeroes of the polynomial $2x^3 + x^2 - 6x - 3$, if two of its zeroes are $\sqrt{3}$ and $-\sqrt{3}$.
30. Find all the zeroes of the polynomial $x^4 + x^3 - 34x^2 - 4x + 120$, if two of its zeroes are 2 and -2 .
31. If the polynomial $6x^4 + 8x^3 + 17x^2 + 21x + 7$ is divided by another polynomial $3x^2 + 4x + 1$, the remainder comes out to be $(ax + b)$, find a and b .
32. If the polynomial $x^4 + 2x^3 + 8x^2 + 12x + 18$ is divided by another polynomial $x^2 + 5$, the remainder comes out to be $px + q$, find the value of p and q .
33. Find the zeroes of a polynomial $x^3 - 5x^2 - 16x + 80$, if its two zeroes are equal in magnitude but opposite in sign.
34. If two zeroes of the polynomial $x^4 + 3x^3 - 20x^2 - 6x + 36$ are $\sqrt{2}$ and $-\sqrt{2}$, find the other zeroes of the polynomial.
35. On dividing $x^3 - 3x^2 + x + 2$ by a polynomial $g(x)$, the quotient and remainder were $x - 2$ and $-2x + 4$ respectively. Find $g(x)$.
36. If the product of zeroes of the polynomial $ax^2 - 6x - 6$ is 4 , find the value of 'a'.
37. If one zero of the polynomial $(a^2 + 9)x^2 + 13x + 6a$ is reciprocal of the other. Find the value of a .
38. Write a quadratic polynomial, sum of whose zeroes is $2\sqrt{3}$ and their product is 2 .
39. Find a polynomial whose zeroes are 2 and -3 .
40. Find the zeroes of the quadratic polynomial $x^2 + 5x + 6$ and verify the relationship between the zeroes and the coefficients.
41. Find the sum and product of zeroes of $p(x) = 2(x^2 - 3) + x$.
42. Find a quadratic polynomial, the sum of whose zeroes is 4 and one zero is 5 .
43. Find the zeroes of the polynomial $p(x) = \sqrt{2}x^2 - 3x - 2\sqrt{2}$.
44. If α and β are the zeroes of $2x^2 + 5(x - 2)$, then find the product of α and β .
45. Find a quadratic polynomial, the sum and product of whose zeroes are 5 and 3 respectively.

46. Find the zeroes of the quadratic polynomial $f(x) = ax^2 + (b^2 - ac)x - bc$ and verify the relationship between the zeroes and its coefficients.
47. Find the zeroes of the following polynomials by factorisation method and verify the relations between the zeroes and the coefficients of the polynomials:
- $4x^2 - 3x - 1$
 - $3x^2 + 4x - 4$
 - $5t^2 + 12t + 7$
 - $t^3 - 2t^2 - 15t$
 - $2x^2 + \frac{7}{2}x + \frac{3}{4}$
 - $4x^2 + 5\sqrt{2}x - 3$
 - $2s^2 - (1 + 2\sqrt{2})s + \sqrt{2}$
 - $v^2 + 4\sqrt{3}v - 15$
 - $y^2 + \frac{3}{2}\sqrt{5}y - 5$
 - $7y^2 - \frac{11}{3}y - \frac{2}{3}$
48. Find the zeroes of the quadratic polynomial $6x^2 - 7x - 3$ and verify the relationship between the zeroes and the coefficients.
49. Find the zeroes of the polynomial $x^2 + \frac{1}{6}x - 2$, and verify the relation between the coefficients and the zeroes of the polynomial.
50. Find the zeroes of the quadratic polynomial $x^2 + 5x + 6$ and verify the relationship between the zeroes and the coefficients.
51. Find a quadratic polynomial, the sum and product of whose zeroes are $\sqrt{2}$ and $-\frac{3}{2}$, respectively. Also find its zeroes.
52. If one zero of the quadratic polynomial $x^2 + 3x + k$ is 2, then find the value of k
53. Given that two of the zeroes of the cubic polynomial $ax^3 + bx^2 + cx + d$ are 0, find the third zero.
54. Given that one of the zeroes of the cubic polynomial $ax^3 + bx^2 + cx + d$ is zero, then find the product of the other two zeroes.
55. If one of the zeroes of the cubic polynomial $x^3 + ax^2 + bx + c$ is -1 , then the product of the other two zeroes

Answer the Questions from 28 to 32 and justify:

56. Can $x^2 - 1$ be the quotient on division of $x^6 + 2x^3 + x - 1$ by a polynomial in x of degree 5?
57. What will the quotient and remainder be on division of $ax^2 + bx + c$ by $px^3 + qx^2 + rx + s$, $p \neq 0$?
58. If on division of a polynomial $p(x)$ by a polynomial $g(x)$, the degree of quotient is zero, what is the relation between the degrees of $p(x)$ and $g(x)$?

59. If on division of a non-zero polynomial $p(x)$ by a polynomial $g(x)$, the remainder is zero, what is the relation between the degrees of $p(x)$ and $g(x)$?
60. Can the quadratic polynomial $x^2 + kx + k$ have equal zeroes for some odd integer $k > 1$?
61. If one of the zeroes of the quadratic polynomial $(k-1)x^2 + kx + 1$ is -3 , then the value of k
62. If the zeroes of the quadratic polynomial $x^2 + (a+1)x + b$ are 2 and -3 , then find the value of a and b .
63. If α and β are zeroes of the quadratic polynomial $x^2 - (k+6)x + 2(2k-1)$. Find the value of k if $\alpha + \beta = \frac{1}{2}\alpha\beta$.
64. Obtain all the zeroes of $3x^4 + 6x^3 - 2x^2 - 10x + 5$, if two of its zeroes are $\sqrt{\frac{5}{3}}$ and $-\sqrt{\frac{5}{3}}$.
65. Obtain all the zeroes of $x^4 - 7x^3 + 17x^2 - 17x + 6$, if two of its zeroes are 3 and 1.
66. Obtain all the zeroes of $x^4 - 7x^2 + 12$, if two of its zeroes are $\sqrt{3}$ and $-\sqrt{3}$.
67. Two zeroes of the cubic polynomial $ax^3 + 3x^2 - bx - 6$ are -1 and -2 . Find the 3rd zero and value of a and b .
68. α , β and γ are the zeroes of cubic polynomial $x^3 + px^2 + qx + 2$ such that $\alpha \cdot \beta + 1 = 0$. Find the value of $2p + q + 5$.
69. Find the number of zeroes in each of the following:

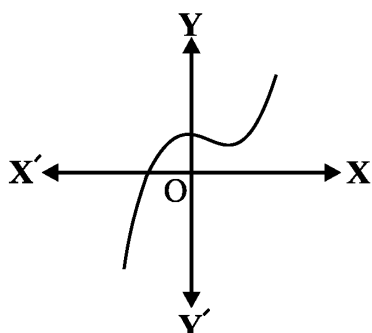

(i)

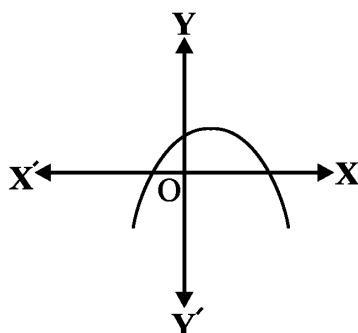

(ii)

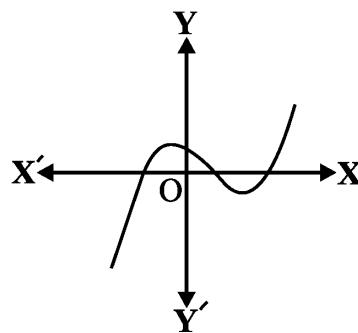

(iii)

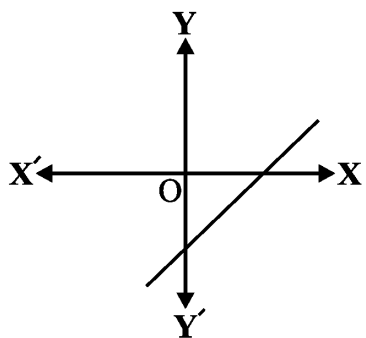

(iv)

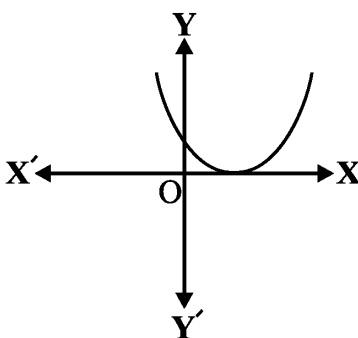

(v)

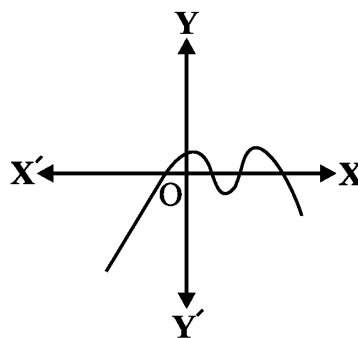

(vi)

70. If the remainder on division of $x^3 + 2x^2 + kx + 3$ by $x - 3$ is 21, find the quotient and the value of k . Hence, find the zeroes of the cubic polynomial $x^3 + 2x^2 + kx - 18$.
71. Find the zeroes of the polynomial $f(x) = x^3 - 5x^2 - 16x + 80$, if its two zeroes are equal in magnitude but opposite in sign.
72. Find the zeroes of the polynomial $f(x) = x^3 - 5x^2 - 2x + 24$, if it is given that the product of two zeroes is 12.
73. Find the zeroes of the polynomial $f(x) = x^3 - px^2 + qx - r$, if it is given that the sum of two zeroes is zero.
74. If the zeroes of the polynomial $x^3 - 3x^2 + x + 1$ are $a - b, a, a + b$, find a and b .
75. If the zeroes of the polynomial $2x^3 - 15x^2 + 37x - 30$ are $a - b, a, a + b$, find all the zeroes.
76. If the zeroes of the polynomial $x^3 - 12x^2 + 39x - 28$ are $a - b, a, a + b$, find all the zeroes.
77. If the polynomial $x^4 - 6x^3 + 16x^2 - 25x + 10$ is divided by another polynomial $x^2 - 2x + k$, the remainder comes out to be $x + a$, find k and a .
78. If the polynomial $6x^4 + 8x^3 - 5x^2 + ax + b$ is exactly divisible by the polynomial $2x^2 - 5$, then find the values of a and b .
79. Find a cubic polynomial with the sum, sum of the product of its zeroes taken two at a time, and the product of its zeroes as 2, -7 , -14 respectively.
80. Find a cubic polynomial with the sum, sum of the product of its zeroes taken two at a time, and the product of its zeroes as 3, -1 , -3 respectively.
81. Find a cubic polynomial whose zeroes are 3, $\frac{1}{2}$ and -1 .
82. Find a cubic polynomial whose zeroes are -2 , -3 and -1 .
83. Find a cubic polynomial whose zeroes are 3, 5 and -2 .
84. Verify that 5, -2 and $\frac{1}{3}$ are the zeroes of the cubic polynomial $p(x) = 3x^3 - 10x^2 - 27x + 10$ and verify the relation between its zeroes and coefficients.
85. Verify that 3, -2 and 1 are the zeroes of the cubic polynomial $p(x) = x^3 - 2x^2 - 5x + 6$ and verify the relation between its zeroes and coefficients.
86. Verify that the numbers given alongside of the cubic polynomials below are their zeroes. Also verify the relationship between the zeroes and the coefficients in each case:
 (i) $2x^3 + x^2 - 5x + 2$; $\frac{1}{2}, 1, -2$ (ii) $x^3 - 4x^2 + 5x - 2$; 2, 1, 1
87. Find the quotient and remainder when $4x^3 + 2x^2 + 5x - 6$ is divided by $2x^2 + 3x + 1$.
88. On dividing $x^4 - 5x + 6$ by a polynomial $g(x)$, the quotient and remainder were $-x^2 - 2$ and $-5x + 10$ respectively. Find $g(x)$.
89. Given that $\sqrt{2}$ is a zero of the cubic polynomial $6x^3 + \sqrt{2}x^2 - 10x - 4\sqrt{2}$, find its other two zeroes.

90. Given that the zeroes of the cubic polynomial $x^3 - 6x^2 + 3x + 10$ are of the form $a, a + b, a + 2b$ for some real numbers a and b , find the values of a and b as well as the zeroes of the given polynomial.
91. For which values of a and b , are the zeroes of $q(x) = x^3 + 2x^2 + a$ also the zeroes of the polynomial $p(x) = x^5 - x^4 - 4x^3 + 3x^2 + 3x + b$? Which zeroes of $p(x)$ are not the zeroes of $q(x)$?
92. Find k so that $x^2 + 2x + k$ is a factor of $2x^4 + x^3 - 14x^2 + 5x + 6$. Also find all the zeroes of the two polynomials.
93. Given that $x - \sqrt{5}$ is a factor of the cubic polynomial $x^3 - 3\sqrt{5}x + 13x - 3\sqrt{5}$, find all the zeroes of the polynomial.
94. For each of the following, find a quadratic polynomial whose sum and product respectively of the zeroes are as given. Also find the zeroes of these polynomials by factorisation.
- (i) $\frac{-8}{3}, \frac{4}{3}$ (ii) $\frac{21}{8}, \frac{5}{16}$
- (iii) $-2\sqrt{3}, -9$ (iv) $\frac{-3}{2\sqrt{5}}, -\frac{1}{2}$
95. If α and β are the zeroes of the quadratic polynomial $f(x) = x^2 - 3x - 2$, then find a quadratic polynomial whose zeroes are $\frac{1}{2\alpha + \beta}$ and $\frac{1}{2\beta + \alpha}$.
96. If α and β are the zeroes of the quadratic polynomial $f(x) = 2x^2 - 5x + 7$, then find a quadratic polynomial whose zeroes are $2\alpha + 3\beta$ and $2\beta + 3\alpha$.
97. If α and β are the zeroes of the quadratic polynomial $f(x) = x^2 - 1$, then find a quadratic polynomial whose zeroes are $\frac{2\alpha}{\beta}$ and $\frac{2\beta}{\alpha}$.
98. If α and β are the zeroes of the quadratic polynomial $f(x) = 6x^2 + x - 2$, then find the value of
- (i) $\alpha - \beta$ (ii) $\alpha^2 + \beta^2$ (iii) $\alpha^4 + \beta^4$ (iv) $\alpha\beta^2 + \alpha^2\beta$
- (v) $\frac{1}{\alpha} + \frac{1}{\beta}$ (vi) $\frac{1}{\alpha} + \frac{1}{\beta} - \alpha\beta$ (vii) $\frac{1}{\alpha} - \frac{1}{\beta}$ (viii) $\alpha^3 + \beta^3$
- (ix) $\frac{\alpha}{\beta} + \frac{\beta}{\alpha}$ (x) $\frac{\alpha^2}{\beta} + \frac{\beta^2}{\alpha}$ (xi) $\frac{\alpha}{\beta} + \frac{\beta}{\alpha} + 2\left(\frac{1}{\alpha} + \frac{1}{\beta}\right) + 3\alpha\beta$
- (xii) $\alpha^4\beta^3 + \alpha^3\beta^4$ (xiii) $\frac{1}{\alpha} + \frac{1}{\beta} - 2\alpha\beta$ (xiv) $\frac{\alpha^2}{\beta^2} + \frac{\beta^2}{\alpha^2}$
99. If α and β are the zeroes of the quadratic polynomial $f(x) = 4x^2 - 5x - 1$, then find the value of
- (i) $\alpha - \beta$ (ii) $\alpha^2 + \beta^2$ (iii) $\alpha^4 + \beta^4$ (iv) $\alpha\beta^2 + \alpha^2\beta$
- (v) $\frac{1}{\alpha} + \frac{1}{\beta}$ (vi) $\frac{1}{\alpha} + \frac{1}{\beta} - \alpha\beta$ (vii) $\frac{1}{\alpha} - \frac{1}{\beta}$ (viii) $\alpha^3 + \beta^3$
- (ix) $\frac{\alpha}{\beta} + \frac{\beta}{\alpha}$ (x) $\frac{\alpha^2}{\beta} + \frac{\beta^2}{\alpha}$ (xi) $\frac{\alpha}{\beta} + \frac{\beta}{\alpha} + 2\left(\frac{1}{\alpha} + \frac{1}{\beta}\right) + 3\alpha\beta$
- (xii) $\alpha^4\beta^3 + \alpha^3\beta^4$ (xiii) $\frac{1}{\alpha} + \frac{1}{\beta} - 2\alpha\beta$ (xiv) $\frac{\alpha^2}{\beta^2} + \frac{\beta^2}{\alpha^2}$

- 100.** If α and β are the zeroes of the quadratic polynomial $f(x) = x^2 + x - 2$, then find the value of
- (i) $\alpha - \beta$ (ii) $\alpha^2 + \beta^2$ (iii) $\alpha^4 + \beta^4$ (iv) $\alpha\beta^2 + \alpha^2\beta$
- (v) $\frac{1}{\alpha} + \frac{1}{\beta}$ (vi) $\frac{1}{\alpha} + \frac{1}{\beta} - \alpha\beta$ (vii) $\frac{1}{\alpha} - \frac{1}{\beta}$ (viii) $\alpha^3 + \beta^3$
- (ix) $\frac{\alpha}{\beta} + \frac{\beta}{\alpha}$ (x) $\frac{\alpha^2}{\beta} + \frac{\beta^2}{\alpha}$ (xi) $\frac{\alpha}{\beta} + \frac{\beta}{\alpha} + 2\left(\frac{1}{\alpha} + \frac{1}{\beta}\right) + 3\alpha\beta$
- (xii) $\alpha^4\beta^3 + \alpha^3\beta^4$ (xiii) $\frac{1}{\alpha} + \frac{1}{\beta} - 2\alpha\beta$ (xiv) $\frac{\alpha^2}{\beta^2} + \frac{\beta^2}{\alpha^2}$
- 101.** If α and β are the zeroes of the quadratic polynomial $f(x) = x^2 - 5x + 4$, then find the value of
- (i) $\alpha - \beta$ (ii) $\alpha^2 + \beta^2$ (iii) $\alpha^4 + \beta^4$ (iv) $\alpha\beta^2 + \alpha^2\beta$
- (v) $\frac{1}{\alpha} + \frac{1}{\beta}$ (vi) $\frac{1}{\alpha} + \frac{1}{\beta} - \alpha\beta$ (vii) $\frac{1}{\alpha} - \frac{1}{\beta}$ (viii) $\alpha^3 + \beta^3$
- (ix) $\frac{\alpha}{\beta} + \frac{\beta}{\alpha}$ (x) $\frac{\alpha^2}{\beta} + \frac{\beta^2}{\alpha}$ (xi) $\frac{\alpha}{\beta} + \frac{\beta}{\alpha} + 2\left(\frac{1}{\alpha} + \frac{1}{\beta}\right) + 3\alpha\beta$
- (xii) $\alpha^4\beta^3 + \alpha^3\beta^4$ (xiii) $\frac{1}{\alpha} + \frac{1}{\beta} - 2\alpha\beta$ (xiv) $\frac{\alpha^2}{\beta^2} + \frac{\beta^2}{\alpha^2}$
- 102.** If α and β are the zeroes of the quadratic polynomial $f(x) = x^2 - 2x + 3$, then find a quadratic polynomial whose zeroes are $\alpha + 2$ and $\beta + 2$
- 103.** If α and β are the zeroes of the quadratic polynomial $f(x) = 3x^2 - 4x + 1$, then find a quadratic polynomial whose zeroes are $\frac{\alpha^2}{\beta}$ and $\frac{\beta^2}{\alpha}$.
- 104.** If α and β are the zeroes of the quadratic polynomial $f(x) = x^2 - 2x + 3$, then find a quadratic polynomial whose zeroes are $\frac{\alpha - 1}{\alpha + 1}$ and $\frac{\beta - 1}{\beta + 1}$.
- 105.** If α and β are the zeroes of the quadratic polynomial $f(x) = x^2 - p(x + 1) - c$, show that $(\alpha + 1)(\beta + 1) = 1 - c$.
- 106.** If α and β are the zeroes of the quadratic polynomial such that $\alpha + \beta = 24$ and $\alpha - \beta = 8$, find a quadratic polynomial having α and β as its zeroes.
- 107.** If sum of the squares of zeroes of the quadratic polynomial $f(x) = x^2 - 8x + k$ is 40, find the value of k .
- 108.** If α and β are the zeroes of the quadratic polynomial $f(x) = kx^2 + 4x + 4$ such that $\alpha^2 + \beta^2 = 24$, find the value of k .
- 109.** If α and β are the zeroes of the quadratic polynomial $f(x) = 2x^2 + 5x + k$ such that $\alpha^2 + \beta^2 + \alpha\beta = \frac{21}{4}$, find the value of k .
- 110.** What must be subtracted from $8x^4 + 14x^3 - 2x^2 + 7x - 8$ so that the resulting polynomial is exactly divisible by $4x^2 + 3x - 2$.
- 111.** What must be subtracted from $4x^4 + 2x^3 - 2x^2 + x - 1$ so that the resulting polynomial is exactly divisible by $x^2 + 2x - 3$.

- 112.** Find all the zeroes of the polynomial $x^4 - 6x^3 - 26x^2 + 138x - 35$, if two of its zeroes are $2 + \sqrt{3}$ and $2 - \sqrt{3}$.
- 113.** Find the values of a and b so that $x^4 + x^3 + 8x^2 + ax + b$ is divisible by $x^2 + 1$.
- 114.** If the polynomial $f(x) = x^4 - 6x^3 + 16x^2 - 25x + 10$ is divided by another polynomial $x^2 - 2x + k$, the remainder comes out to be $x + a$, find k and a.
- 115.** If α and β are the zeroes of the quadratic polynomial $f(x) = x^2 - 2x - 8$, then find the value of
- (i) $\alpha - \beta$ (ii) $\alpha^2 + \beta^2$ (iii) $\alpha^4 + \beta^4$ (iv) $\alpha\beta^2 + \alpha^2\beta$
- (v) $\frac{1}{\alpha} + \frac{1}{\beta}$ (vi) $\frac{1}{\alpha} + \frac{1}{\beta} - \alpha\beta$ (vii) $\frac{1}{\alpha} - \frac{1}{\beta}$ (viii) $\alpha^3 + \beta^3$
- (ix) $\frac{\alpha}{\beta} + \frac{\beta}{\alpha}$ (x) $\frac{\alpha^2}{\beta} + \frac{\beta^2}{\alpha}$ (xi) $\frac{\alpha}{\beta} + \frac{\beta}{\alpha} + 2\left(\frac{1}{\alpha} + \frac{1}{\beta}\right) + 3\alpha\beta$
- (xii) $\alpha^4\beta^3 + \alpha^3\beta^4$ (xiii) $\frac{1}{\alpha} + \frac{1}{\beta} - 2\alpha\beta$ (xiv) $\frac{\alpha^2}{\beta^2} + \frac{\beta^2}{\alpha^2}$
-

CLASS X : CHAPTER - 3
PAIR OF LINEAR EQUATIONS IN TWO VARIABLES

IMPORTANT FORMULAS & CONCEPTS

- ❖ An equation of the form $ax + by + c = 0$, where a, b and c are real numbers ($a \neq 0, b \neq 0$), is called a linear equation in two variables x and y .
- ❖ The numbers a and b are called the coefficients of the equation $ax + by + c = 0$ and the number c is called the constant of the equation $ax + by + c = 0$.

Two linear equations in the same two variables are called a pair of linear equations in two variables. The most general form of a pair of linear equations is

$$a_1x + b_1y + c_1 = 0$$

$$a_2x + b_2y + c_2 = 0$$

where $a_1, a_2, b_1, b_2, c_1, c_2$ are real numbers, such that $a_1^2 + b_1^2 \neq 0, a_2^2 + b_2^2 \neq 0$.

CONSISTENT SYSTEM

A system of simultaneous linear equations is said to be consistent, if it has at least one solution.

INCONSISTENT SYSTEM

A system of simultaneous linear equations is said to be inconsistent, if it has no solution.

METHOD TO SOLVE A PAIR OF LINEAR EQUATION OF TWO VARIABLES

A pair of linear equations in two variables can be represented, and solved, by the:

- (i) graphical method (ii) algebraic method

GRAPHICAL METHOD OF SOLUTION OF A PAIR OF LINEAR EQUATIONS

The graph of a pair of linear equations in two variables is represented by two lines.

1. If the lines intersect at a point, then that point gives the unique solution of the two equations. In this case, the pair of equations is **consistent**.

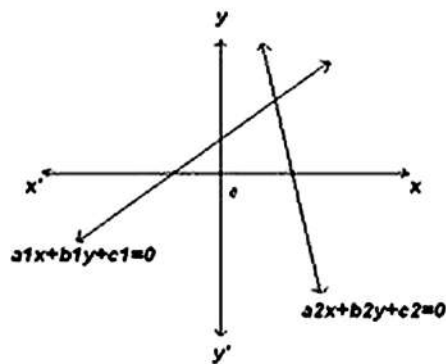

2. If the lines coincide, then there are infinitely many solutions — each point on the line being a solution. In this case, the pair of equations is **dependent (consistent)**.

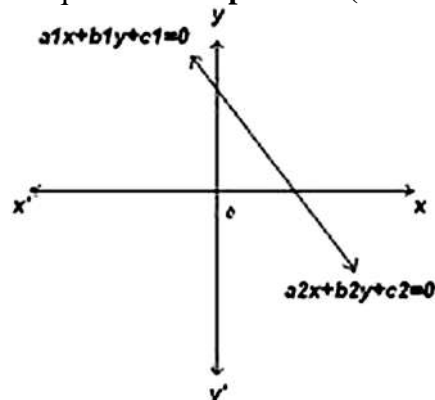

3. If the lines are parallel, then the pair of equations has no solution. In this case, the pair of equations is **inconsistent**.

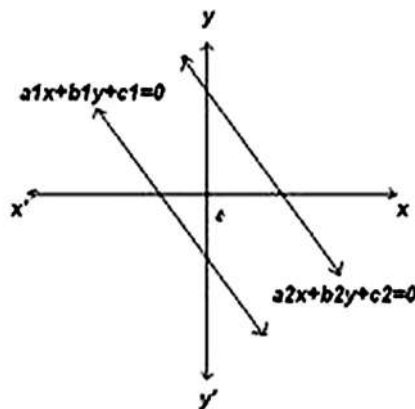

Algebraic interpretation of pair of linear equations in two variables

The pair of linear equations represented by these lines $a_1x + b_1y + c_1 = 0$ and $a_2x + b_2y + c_2 = 0$

1. If $\frac{a_1}{a_2} \neq \frac{b_1}{b_2}$ then the pair of linear equations has exactly one solution.
2. If $\frac{a_1}{a_2} = \frac{b_1}{b_2} = \frac{c_1}{c_2}$ then the pair of linear equations has infinitely many solutions.
3. If $\frac{a_1}{a_2} = \frac{b_1}{b_2} \neq \frac{c_1}{c_2}$ then the pair of linear equations has no solution.

S. No.	Pair of lines	Compare the ratios	Graphical representation	Algebraic interpretation
1	$a_1x + b_1y + c_1 = 0$ $a_2x + b_2y + c_2 = 0$	$\frac{a_1}{a_2} \neq \frac{b_1}{b_2}$	Intersecting lines	Unique solution (Exactly one solution)
2	$a_1x + b_1y + c_1 = 0$ $a_2x + b_2y + c_2 = 0$	$\frac{a_1}{a_2} = \frac{b_1}{b_2} = \frac{c_1}{c_2}$	Coincident lines	Infinitely many solutions
3	$a_1x + b_1y + c_1 = 0$ $a_2x + b_2y + c_2 = 0$	$\frac{a_1}{a_2} = \frac{b_1}{b_2} \neq \frac{c_1}{c_2}$	Parallel lines	No solution

ALGEBRAIC METHODS OF SOLVING A PAIR OF LINEAR EQUATIONS

Substitution Method

Following are the steps to solve the pair of linear equations by substitution method:

$$a_1x + b_1y + c_1 = 0 \dots \text{(i) and}$$

$$a_2x + b_2y + c_2 = 0 \dots \text{(ii)}$$

Step 1: We pick either of the equations and write one variable in terms of the other

$$y = -\frac{a_1}{b_1}x - \frac{c_1}{b_1} \dots \text{(iii)}$$

Step 2: Substitute the value of x in equation (i) from equation (iii) obtained in step 1.

Step 3: Substituting this value of y in equation (iii) obtained in step 1, we get the values of x and y.

Elimination Method

Following are the steps to solve the pair of linear equations by elimination method:

Step 1: First multiply both the equations by some suitable non-zero constants to make the coefficients of one variable (either x or y) numerically equal.

Step 2: Then add or subtract one equation from the other so that one variable gets eliminated.

- ❖ If you get an equation in one variable, go to Step 3.
- ❖ If in Step 2, we obtain a true statement involving no variable, then the original pair of equations has infinitely many solutions.

- ❖ If in Step 2, we obtain a false statement involving no variable, then the original pair of equations has no solution, i.e., it is inconsistent.

Step 3: Solve the equation in one variable (x or y) so obtained to get its value.

Step 4: Substitute this value of x (or y) in either of the original equations to get the value of the other variable.

Cross - Multiplication Method

Let the pair of linear equations be:

$$a_1x + b_1y + c_1 = 0 \dots (1) \text{ and}$$

$$a_2x + b_2y + c_2 = 0 \dots (2)$$

$$\frac{x}{b_1c_2 - b_2c_1} = \frac{y}{c_1a_2 - c_2a_1} = \frac{1}{a_1b_2 - a_2b_1} \dots\dots\dots (3)$$

$$\Rightarrow x = \frac{b_1c_2 - b_2c_1}{a_1b_2 - a_2b_1} \text{ and } y = \frac{c_1a_2 - c_2a_1}{a_1b_2 - a_2b_1}$$

In remembering the above result, the following diagram may be helpful :

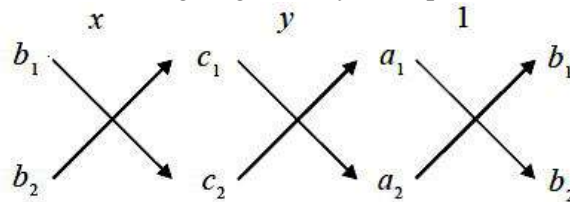

The arrows between the two numbers indicate that they are to be multiplied and the second product is to be subtracted from the first.

For solving a pair of linear equations by this method, we will follow the following steps :

Step 1 : Write the given equations in the form (1) and (2).

Step 2 : Taking the help of the diagram above, write Equations as given in (3).

Step 3 : Find x and y, provided $a_1b_2 - a_2b_1 \neq 0$

Step 2 above gives you an indication of why this method is called the **cross-multiplication method**.

MCQ WORKSHEET-I
CLASS X : CHAPTER - 3
PAIR OF LINEAR EQUATIONS IN TWO VARIABLES

1. The pair of equations $y = 0$ and $y = -7$ has
 (a) one solution (b) two solution (c) infinitely many solutions (d) no solution
2. The pair of equations $x = a$ and $y = b$ graphically represents the lines which are
 (a) parallel (b) intersecting at (a, b)
 (c) coincident (d) intersecting at (b, a)
3. The value of c for which the pair of equations $cx - y = 2$ and $6x - 2y = 3$ will have infinitely many solutions is
 (a) 3 (b) -3 (c) -12 (d) no value
4. When lines l_1 and l_2 are coincident, then the graphical solution system of linear equation have
 (a) infinite number of solutions (b) unique solution
 (c) no solution (d) one solution
5. When lines l_1 and l_2 are parallel, then the graphical solution system of linear equation have
 (a) infinite number of solutions (b) unique solution
 (c) no solution (d) one solution
6. The coordinates of the vertices of triangle formed between the lines and y-axis from the graph is
 (a) $(0, 5)$, $(0, 0)$ and $(6.5, 0)$ (b) $(4, 2)$, $(0, 0)$ and $(6.5, 0)$
 (c) $(4, 2)$, $(0, 0)$ and $(0, 5)$ (d) none of these
7. Five years ago Nuri was thrice old as Sonu. Ten years later, Nuri will be twice as old as Sonu. The present age, in years, of Nuri and Sonu are respectively
 (a) 50 and 20 (b) 60 and 30 (c) 70 and 40 (d) 40 and 10
8. The pair of equations $5x - 15y = 8$ and $3x - 9y = 24/5$ has
 (a) infinite number of solutions (b) unique solution
 (c) no solution (d) one solution
9. The pair of equations $x + 2y + 5 = 0$ and $-3x - 6y + 1 = 0$ have
 (a) infinite number of solutions (b) unique solution
 (c) no solution (d) one solution
10. The sum of the digits of a two digit number is 9. If 27 is added to it, the digits of the numbers get reversed. The number is
 (a) 36 (b) 72 (c) 63 (d) 25

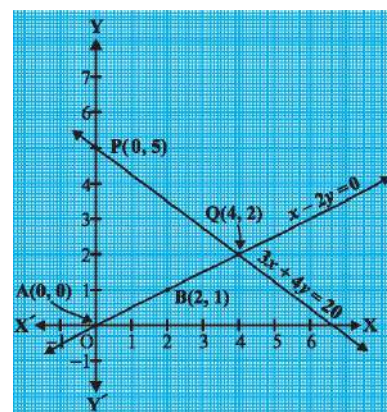

MCQ WORKSHEET-II
CLASS X : CHAPTER - 3
PAIR OF LINEAR EQUATIONS IN TWO VARIABLES

1. If a pair of equation is consistent, then the lines will be
(a) parallel (b) always coincident
(c) always intersecting (d) intersecting or coincident
2. The solution of the equations $x + y = 14$ and $x - y = 4$ is
(a) $x = 9$ and $y = 5$ (b) $x = 5$ and $y = 9$ (c) $x = 7$ and $y = 7$ (d) $x = 10$ and $y = 4$
3. The sum of the numerator and denominator of a fraction is 12. If the denominator is increased by b^3 , the fraction becomes $\frac{1}{2}$, then the fraction
(a) $\frac{4}{7}$ (b) $\frac{5}{7}$ (c) $\frac{6}{7}$ (d) $\frac{3}{7}$
4. The value of k for which the system of equations $x - 2y = 3$ and $3x + ky = 1$ has a unique solution is
(a) $k = -6$ (b) $k \neq -6$ (c) $k = 0$ (d) no value
5. If a pair of equation is inconsistent, then the lines will be
(a) parallel (b) always coincident
(c) always intersecting (d) intersecting or coincident
6. The value of k for which the system of equations $2x + 3y = 5$ and $4x + ky = 10$ has infinite many solution is
(a) $k = -3$ (b) $k \neq -3$ (c) $k = 0$ (d) none of these
7. The value of k for which the system of equations $kx - y = 2$ and $6x - 2y = 3$ has a unique solution is
(a) $k = -3$ (b) $k \neq -3$ (c) $k = 0$ (d) $k \neq 0$
8. Sum of two numbers is 35 and their difference is 13, then the numbers are
(a) 24 and 12 (b) 24 and 11 (c) 12 and 11 (d) none of these
9. The solution of the equations $0.4x + 0.3y = 1.7$ and $0.7x - 0.2y = 0.8$ is
(a) $x = 1$ and $y = 2$ (b) $x = 2$ and $y = 3$ (c) $x = 3$ and $y = 4$ (d) $x = 5$ and $y = 4$
10. The solution of the equations $x + 2y = 1.5$ and $2x + y = 1.5$ is
(a) $x = 1$ and $y = 1$ (b) $x = 1.5$ and $y = 1.5$ (c) $x = 0.5$ and $y = 0.5$ (d) none of these
11. The value of k for which the system of equations $x + 2y = 3$ and $5x + ky + 7 = 0$ has no solution is
(a) 10 (b) 6 (c) 3 (d) 1
12. The value of k for which the system of equations $3x + 5y = 0$ and $kx + 10y = 0$ has a non-zero solution is
(a) 0 (b) 2 (c) 6 (d) 8



MCQ WORKSHEET-II
CLASS X : CHAPTER - 3
PAIR OF LINEAR EQUATIONS IN TWO VARIABLES

1. Sum of two numbers is 50 and their difference is 10, then the numbers are
(a) 30 and 20 (b) 24 and 14 (c) 12 and 2 (d) none of these
 2. The sum of the digits of a two-digit number is 12. The number obtained by interchanging its digit exceeds the given number by 18, then the number is
(a) 72 (b) 75 (c) 57 (d) none of these
 3. The sum of a two-digit number and the number obtained by interchanging its digit is 99. If the digits differ by 3, then the number is
(a) 36 (b) 33 (c) 66 (d) none of these
 4. Seven times a two-digit number is equal to four times the number obtained by reversing the order of its digit. If the difference between the digits is 3, then the number is
(a) 36 (b) 33 (c) 66 (d) none of these
 5. A two-digit number is 4 more than 6 times the sum of its digits. If 18 is subtracted from the number, the digits are reversed, then the number is
(a) 36 (b) 46 (c) 64 (d) none of these
 6. The sum of two numbers is 1000 and the difference between their squares is 25600, then the numbers are
(a) 616 and 384 (b) 628 and 372 (c) 564 and 436 (d) none of these
 7. Five years ago, A was thrice as old as B and ten years later A shall be twice as old as B, then the present age of A is
(a) 20 (b) 50 (c) 30 (d) none of these
 8. The sum of thrice the first and the second is 142 and four times the first exceeds the second by 138, then the numbers are
(a) 40 and 20 (b) 40 and 22 (c) 12 and 22 (d) none of these
 9. The sum of twice the first and thrice the second is 92 and four times the first exceeds seven times the second by 2, then the numbers are
(a) 25 and 20 (b) 25 and 14 (c) 14 and 22 (d) none of these
 10. The difference between two numbers is 14 and the difference between their squares is 448, then the numbers are
(a) 25 and 9 (b) 22 and 9 (c) 23 and 9 (d) none of these
 11. The solution of the system of linear equations $\frac{x}{a} + \frac{y}{b} = a + b$; $\frac{x}{a^2} + \frac{y}{b^2} = 2$ are
(a) $x = a$ and $y = b$ (b) $x = a^2$ and $y = b^2$ (c) $x = 1$ and $y = 1$ (d) none of these
 12. The solution of the system of linear equations $2(ax - by) + (a + 4b) = 0$; $2(bx + ay) + (b - 4a) = 0$ are
(a) $x = a$ and $y = b$ (b) $x = -1$ and $y = -1$ (c) $x = 1$ and $y = 1$ (d) none of these
-

MCQ WORKSHEET-III
CLASS X : CHAPTER - 3
PAIR OF LINEAR EQUATIONS IN TWO VARIABLES

1. The pair of equations $3x + 4y = 18$ and $4x + \frac{16}{3}y = 24$ has
(a) infinite number of solutions (b) unique solution
(c) no solution (d) cannot say anything
2. If the pair of equations $2x + 3y = 7$ and $kx + \frac{9}{2}y = 12$ have no solution, then the value of k is:
(a) $\frac{2}{3}$ (b) -3 (c) 3 (d) $\frac{3}{2}$
3. The equations $x - y = 0.9$ and $\frac{11}{x+y} = 2$ have the solution:
(a) $x = 5$ and $y = a$ (b) $x = 3, 2$ and $y = 2, 3$ (c) $x = 3$ and $y = 2$ (d) none of these
4. If $bx + ay = a^2 + b^2$ and $ax - by = 0$, then the value of $x - y$ equals:
(a) $a - b$ (b) $b - a$ (c) $a^2 - b^2$ (d) $b^2 + a^2$.
5. If $2x + 3y = 0$ and $4x - 3y = 0$, then $x + y$ equals:
(a) 0 (b) -1 (c) 1 (d) 2
6. If $\sqrt{ax} - \sqrt{by} = b - a$ and $\sqrt{bx} - \sqrt{ay} = 0$, then the value of x, y is:
(a) $a + b$ (b) $a - b$ (c) \sqrt{ab} (d) $-\sqrt{ab}$
7. If $\frac{2}{x} + \frac{3}{y} = 13$ and $\frac{5}{x} - \frac{4}{y} = -2$, then $x + y$ equals:
(a) $\frac{1}{6}$ (b) $-\frac{1}{6}$ (c) $\frac{5}{6}$ (d) $-\frac{5}{6}$
8. If $31x + 43y = 117$ and $43x + 31y = 105$, then value of $x - y$ is:
(a) $\frac{1}{3}$ (b) -3 (c) 3 (d) $-\frac{1}{3}$
9. If $19x - 17y = 55$ and $17x - 19y = 53$, then the value of $x - y$ is:
(a) $\frac{1}{3}$ (b) -3 (c) 3 (d) 5
10. If $\frac{x}{2} + y = 0.8$ and $\frac{7}{\left(x + \frac{y}{2}\right)} = 10$, then the value of $x + y$ is:
(a) 1 (b) -0.8 (c) 0.6 (d) 0.5
11. If $(6, k)$ is a solution of the equation $3x + y - 22 = 0$, then the value of k is:
(a) 4 (b) -4 (c) 3 (d) -3

12. If $3x - 5y = 1$, $\frac{2x}{x-y} = 4$, then the value of $x + y$ is

- (a) $\frac{1}{3}$ (b) -3 (c) 3 (d) $-\frac{1}{3}$

13. If $3x + 2y = 13$ and $3x - 2y = 5$, then the value of $x + y$ is:

- (a) 5 (b) 3 (c) 7 (d) none of these

14. If the pair of equations $2x + 3y = 5$ and $5x + \frac{15}{2}y = k$ represent two coincident lines, then the value of k is:

- (a) -5 (b) $\frac{-25}{2}$ (c) $\frac{25}{2}$ (d) $\frac{-5}{2}$

15. Rs. 4900 were divided among 150 children. If each girl gets Rs. 50 and a boy gets Rs. 25, then the number of boys is:

- (a) 100 (b) 102 (c) 104 (d) 105

PRACTICE QUESTIONS
CLASS X : CHAPTER - 3
PAIR OF LINEAR EQUATIONS IN TWO VARIABLES
SOLVING EQUATIONS

Solve for x and y:

1. $11x + 15y + 23 = 0$; $7x - 2y - 20 = 0$.

2. $2x + y = 7$; $4x - 3y + 1 = 0$.

3. $23x - 29y = 98$; $29x - 23y = 110$.

4. $2x + 5y = \frac{8}{3}$; $3x - 2y = \frac{5}{6}$.

5. $4x - 3y = 8$; $6x - y = \frac{29}{3}$.

6. $2x - \frac{3}{4}y = 3$; $5x = 2y + 7$.

7. $2x - 3y = 13$; $7x - 2y = 20$.

8. $3x - 5y - 19 = 0$; $-7x + 3y + 1 = 0$.

9. $2x - 3y + 8 = 0$; $x - 4y + 7 = 0$.

10. $x + y = 5xy$; $3x + 2y = 13xy$; $x \neq 0, y \neq 0$.

11. $152x - 378y = -74$; $-378x + 152y = -604$.

12. $47x + 31y = 63$; $31x + 47y = 15$.

13. $71x + 37y = 253$; $37x + 71y = 287$.

14. $37x + 43y = 123$; $43x + 37y = 117$.

15. $217x + 131y = 913$; $131x + 217y = 827$.

16. $41x - 17y = 99$; $17x - 41y = 75$.

17. $\frac{5}{x} + 6y = 13$; $\frac{3}{x} + 4y = 7$, $x \neq 0$

18. $\frac{2}{x} + \frac{3}{y} = \frac{9}{xy}$; $\frac{4}{x} + \frac{9}{y} = \frac{21}{xy}$ ($x \neq 0, y \neq 0$)

19. $\frac{5}{x} - \frac{3}{y} = 1$; $\frac{3}{2x} + \frac{2}{3y} = 5$ ($x \neq 0, y \neq 0$)

20. $\frac{1}{7x} + \frac{1}{6y} = 3$; $\frac{1}{2x} - \frac{1}{3y} = 5$ ($x \neq 0, y \neq 0$)

21. $\frac{3}{x} - \frac{1}{y} + 9 = 0$; $\frac{2}{x} + \frac{3}{y} = 5$ ($x \neq 0, y \neq 0$)
22. $2x - \frac{3}{y} = 9$; $3x + \frac{7}{y} = 2$, $y \neq 0$
23. $x + \frac{6}{y} = 6$; $3x - \frac{8}{y} = 5$, $y \neq 0$
24. $\frac{4}{x} + 5y = 7$; $\frac{3}{x} + 4y = 5$, $x \neq 0$
25. $\frac{x}{3} + \frac{y}{4} = 11$; $\frac{5x}{6} - \frac{y}{3} + 7 = 0$
26. $\frac{x+y-8}{2} = \frac{x+2y-14}{3} = \frac{3x+y-12}{11}$
27. $\frac{x+y}{xy} = 2$; $\frac{x-y}{xy} = 6$, $x \neq 0, y \neq 0$.
28. $\frac{xy}{x+y} = \frac{6}{5}$; $\frac{xy}{y-x} = 6$; $x+y \neq 0, y-x \neq 0$.
29. $\frac{3x+9y}{xy} = 11$; $\frac{6x+3y}{xy} = 7$, $x \neq 0, y \neq 0$.
30. $\frac{x+1}{2} + \frac{y-1}{3} = 8$; $\frac{x-1}{3} + \frac{y+1}{2} = 9$.
31. $\frac{5}{x-1} + \frac{1}{y-2} = 2$; $\frac{6}{x-1} - \frac{3}{y-2} = 1$, $x \neq 1$ and $y \neq 2$.
32. $\frac{2x+5y}{xy} = 6$; $\frac{4x-5y}{xy} = -3$, $x \neq 0$ and $y \neq 0$
33. $\frac{1}{2(2x+3y)} + \frac{12}{7(3x-2y)} = \frac{1}{2}$; $\frac{7}{(2x+3y)} + \frac{4}{(3x-2y)} = 2$.
34. $\frac{1}{2(x+2y)} + \frac{5}{3(3x-2y)} = -\frac{3}{2}$; $\frac{5}{4(x+2y)} - \frac{3}{5(3x-2y)} = \frac{61}{60}$.
35. $\frac{5}{x+1} - \frac{2}{y-1} = \frac{1}{2}$; $\frac{10}{x+1} + \frac{2}{y-2} = \frac{5}{2}$, $x \neq -1$ and $y \neq 1$.
36. $\frac{3}{x+y} + \frac{2}{x-y} = 2$; $\frac{9}{x+y} - \frac{4}{x-y} = 1$, $x+y \neq 0$ and $x-y \neq 0$.
37. $\frac{57}{x+y} + \frac{6}{x-y} = 5$; $\frac{38}{x+y} + \frac{21}{x-y} = 9$, $x+y \neq 0$ and $x-y \neq 0$.
38. $\frac{40}{x+y} + \frac{2}{x-y} = 2$; $\frac{25}{x+y} - \frac{3}{x-y} = 1$, $x+y \neq 0$ and $x-y \neq 0$.
39. $\frac{44}{x+y} + \frac{30}{x-y} = 10$; $\frac{55}{x+y} + \frac{40}{x-y} = 13$, $x+y \neq 0$ and $x-y \neq 0$.

40. $\frac{b}{a}x + \frac{a}{b}y = a^2 + b^2; x + y = 2ab$

41. $ax + by = a - b; bx - ay = a + b.$

42. $\frac{b^2x}{a} + \frac{a^2y}{b} = ab(a + b); b^2x + a^2y = 2a^2b^2$

43. $2(ax - by) + (a + 4b) = 0; 2(bx + ay) + (b - 4a) = 0$

44. $(a - b)x + (a + b)y = a^2 - 2ab - b^2; (a + b)(x + y) = a^2 + b^2$

45. $\frac{x}{a} + \frac{y}{b} = a + b; \frac{x}{a^2} + \frac{y}{b^2} = 2$

46. $\frac{ax}{b} - \frac{by}{a} = a + b; ax - by = 2ab.$

47. $\frac{x}{a} = \frac{y}{b}; ax + by = a^2 + b^2$

48. $2ax + 3by = a + 2b; 3ax + 2by = 2a + b.$

49. $\frac{a}{x} - \frac{b}{y} = 0; \frac{ab^2}{x} + \frac{a^2b}{y} = a^2 + b^2, \text{ where } x \neq 0 \text{ and } y \neq 0.$

50. $mx - ny = m^2 - n^2; x + y = 2m.$

51. $6(ax + by) = 3a + 2b; 6(bx - ay) = 3b - 2a.$

52. $\frac{x}{a} + \frac{y}{b} = 2; ax - by = a^2 - b^2.$

53. $\frac{bx}{a} - \frac{ay}{b} + a + b = 0; bx - ay + 2ab = 0.$

54. $ax - by = a^2 + b^2; x + y = 2a.$

55. $\frac{3a}{x} - \frac{2b}{y} + 5 = 0; \frac{a}{x} + \frac{3b}{y} - 2 = 0 \text{ (} x \neq 0, y \neq 0 \text{)}.$

PRACTICE QUESTIONS
CLASS X : CHAPTER - 3
PAIR OF LINEAR EQUATIONS IN TWO VARIABLES
CONDITIONS FOR SOLVING LINEAR EQUATIONS

1. Find the value of k , so that the following system of equations has no solution:

$$3x - y - 5 = 0; 6x - 2y - k = 0.$$

2. Find the value of k , so that the following system of equations has a non-zero solution:

$$3x + 5y = 0; kx + 10y = 0.$$

Find the value of k , so that the following system of equations has no solution:

3. $3x + y = 1; (2k - 1)x + (k - 1)y = (2k - 1).$

4. $3x + y = 1; (2k - 1)x + (k - 1)y = (2k + 1).$

5. $x - 2y = 3; 3x + ky = 1.$

6. $x + 2y = 5; 3x + ky + 15 = 0.$

7. $kx + 2y = 5; 3x - 4y = 10.$

8. $x + 2y = 3; 5x + ky + 7 = 0.$

9. $8x + 5y = 9; kx + 10y = 15.$

10. $(3k + 1)x + 3y - 2 = 0; (k^2 + 1)x + (k - 2)y - 5 = 0.$

11. $kx + 3y = 3; 12x + ky = 6.$

Find the value of k , so that the following system of equations has a unique solution:

12. $x - 2y = 3; 3x + ky = 1.$

13. $x + 2y = 5; 3x + ky + 15 = 0.$

14. $kx + 2y = 5; 3x - 4y = 10.$

15. $x + 2y = 3; 5x + ky + 7 = 0.$

16. $8x + 5y = 9; kx + 10y = 15.$

17. $kx + 3y = (k - 3); 12x + ky = k.$

18. $kx + 2y = 5; 3x + y = 1.$

19. $x - 2y = 3; 3x + ky = 1.$

20. $4x - 5y = k; 2x - 3y = 12.$

For what value of k , the following pair of linear equations has infinite number of solutions:

21. $kx + 3y = (2k + 1); 2(k + 1)x + 9y = (7k + 1).$

22. $2x + 3y = 2; (k + 2)x + (2k + 1)y = 2(k - 1).$

23. $x + (2k - 1)y = 4; kx + 6y = k + 6.$

24. $(k-1)x - y = 5$; $(k+1)x + (1-k)y = (3k+1)$.

25. $x + (k+1)y = 5$; $(k+1)x + 9y = (8k-1)$.

26. $2x + 3y = 7$; $(k-1)x + (k+2)y = 3k$.

27. $2x + (k-2)y = k$; $6x + (2k-1)y = (2k+5)$.

Find the value of a and b for which each of the following systems of linear equations has a infinite number of solutions:

28. $(a-1)x + 3y = 2$; $6x + (1-2b)y = 6$.

29. $2x - 3y = 7$; $(a+b)x - (a+b-3)y = 4a+b$.

30. $2x + 3y = 7$; $(a+b+1)x + (a+2b+2)y = 4(a+b)+1$.

31. $2x + 3y = 7$; $a(x+y) - b(x-y) = 3a+b-2$

32. $(2a-1)x + 3y = 5$; $3x + (b-1)y = 2$.

33. Find the value of k, so that the following system of equations has a non-zero solution:

$$5x - 3y = 0; 2x + ky = 0.$$

Show that the following system of the equations has a unique solution and hence find the solution of the given system of equations.

34. $\frac{x}{3} + \frac{y}{2} = 3$; $x - 2y = 2$

35. $3x + 5y = 12$; $5x + 3y = 4$.



PRACTICE QUESTIONS
CLASS X : CHAPTER - 3
PAIR OF LINEAR EQUATIONS IN TWO VARIABLES
GRAPHICAL QUESTIONS

Solve each of the following system of linear equations graphically:

1. $x + 2y = 3$; $4x + 3y = 2$.
2. $2x + 3y = 8$; $x - 2y + 3 = 0$.
3. $x + 2y + 2 = 0$; $3x + 2y - 2 = 0$.
4. $4x + 3y = 5$; $2y - x = 7$.
5. $2x - 3y = 1$; $3x - 4y = 1$.
6. $2x + 3y = 4$; $3x - y = -5$.
7. $x - y + 1 = 0$; $3x + 2y - 12 = 0$.
8. $3x + 2y = 4$; $2x - 3y = 7$.
9. $2x + 3y = 2$; $x - 2y = 8$.
10. $2x - 5y + 4 = 0$; $2x + y - 8 = 0$.
11. $3x + y + 1 = 0$; $2x - 3y + 8 = 0$.
12. Solve the following system of linear equations graphically: $2x - 3y - 17 = 0$; $4x + y - 13 = 0$.
Shade the region bounded by the above lines and x-axis.
13. Solve the following system of linear equations graphically: $2x + 3y = 4$; $3x - y = -5$. Shade the region bounded by the above lines and y-axis.
14. Solve the following system of linear equations graphically: $4x - y = 4$; $3x + 2y = 14$. Shade the region bounded by the above lines and y-axis.
15. Solve the following system of linear equations graphically: $x + 2y = 5$; $2x - 3y = -4$. Shade the region bounded by the above lines and y-axis.
16. Draw the graphs of the equations $4x - y - 8 = 0$; $2x - 3y + 6 = 0$. Also determine the vertices of the triangle formed by the lines and x-axis.
17. Solve the following system of linear equations graphically: $2x - y = 1$; $x - y = -1$. Shade the region bounded by the above lines and y-axis.
18. Solve the following system of linear equations graphically: $5x - y = 7$; $x - y + 1 = 0$. Calculate the area bounded by these lines and y-axis.

19. Solve the following system of linear equations graphically: $4x - 3y + 4 = 0$; $4x + 3y - 20 = 0$. Calculate the area bounded by these lines and x-axis.
20. Solve the following system of linear equations graphically: $4x - 5y - 20 = 0$; $3x + 5y - 15 = 0$. Find the coordinates of the vertices of the triangle formed by these lines and y-axis.
21. Solve the following system of linear equations graphically: $2x - 5y + 4 = 0$; $2x + y - 8 = 0$. Find the points where these lines meet the y-axis.
22. Solve the following system of linear equations graphically: $2x + y - 5 = 0$; $x + y - 3 = 0$. Find the points where these lines meet the y-axis.
23. Solve the following system of linear equations graphically: $4x - 5y + 16 = 0$; $2x + y - 6 = 0$. Find the coordinates of the vertices of the triangle formed by these lines and y-axis.
24. Draw the graphs of the equations $x - y + 1 = 0$ and $3x + 2y - 12 = 0$. Determine the coordinates of the vertices of the triangle formed by these lines and the x-axis, and shade the triangular region.
25. Solve the following system of linear equations graphically: $3x + y - 11 = 0$; $x - y - 1 = 0$. Shade the region bounded by these lines and the y-axis. Find the points where these lines cut the y-axis.
-

PRACTICE QUESTIONS
CLASS X : CHAPTER – 3
PAIR OF LINEAR EQUATIONS IN TWO VARIABLES
WORD PROBLEMS

I. NUMBER BASED QUESTIONS

SIMPLE PROBLEMS

1. The sum of two numbers is 137 and their difference is 43. Find the numbers.
2. The sum of thrice the first and the second is 142 and four times the first exceeds the second by 138, then find the numbers.
3. Sum of two numbers is 50 and their difference is 10, then find the numbers.
4. The sum of twice the first and thrice the second is 92 and four times the first exceeds seven times the second by 2, then find the numbers.
5. The sum of two numbers is 1000 and the difference between their squares is 25600, then find the numbers.
6. The difference between two numbers is 14 and the difference between their squares is 448, then find the numbers.
7. The sum of two natural numbers is 8 and the sum of their reciprocals is $\frac{8}{15}$. Find the numbers.

TWO-DIGIT PROBLEMS

1. The sum of the digits of a two digit number is 12. The number obtained by interchanging the two digits exceeds the given number by 18. Find the number.
2. Seven times a two-digit number is equal to four times the number obtained by reversing the order of its digit. If the difference between the digits is 3, then find the number.
3. The sum of the digits of a two digit number is 9. Also, nine times this number is twice the number obtained by reversing the order of the digits. Find the number.
4. The sum of the digits of a two digit number is 9. If 27 is added to it, the digits of the numbers get reversed. Find the number.
5. The sum of a two-digit number and the number obtained by reversing the digits is 66. If the digits of the number differ by 2, find the number. How many such numbers are there?
6. A two-digit number is 4 more than 6 times the sum of its digit. If 18 is subtracted from the number, the digits are reversed. Find the number.

7. The sum of a two-digit number and the number obtained by reversing the digits is 99. If the digits differ by 3, find the number.
8. The sum of a two-digit number and the number formed by interchanging its digit is 110. If 10 is subtracted from the original number, the new number is 4 more than 5 times the sum of the digits of the original number. Find the original number.
9. A two-digit number is 3 more than 4 times the sum of its digit. If 18 is added to the number, the digits are reversed. Find the number.
10. The sum of the digits of a two digit number is 15. The number obtained by interchanging the two digits exceeds the given number by 9. Find the number.

FRACTION PROBLEMS

1. A fraction becomes $\frac{9}{11}$, if 2 is added to both the numerator and the denominator. If 3 is added to both the numerator and the denominator it becomes $\frac{5}{6}$. Find the fraction.
2. The sum of numerator and denominator of a fraction is 12. If the denominator is increased by 3 then the fraction becomes $\frac{1}{2}$. Find the fraction.
3. If 1 is added to both the numerator and denominator of a given fraction, it becomes $\frac{4}{5}$. If however, 5 is subtracted from both the numerator and denominator, the fraction becomes $\frac{1}{2}$. Find the fraction.
4. In a given fraction, if the numerator is multiplied by 2 and the denominator is reduced by 5, we get $\frac{6}{5}$. But if the numerator of the given fraction is increased by 8 and the denominator is doubled, we get $\frac{2}{5}$. Find the fraction.
5. The denominator of a fraction is greater than its numerator by 11. If 8 is added to both its numerator and denominator, it reduces to $\frac{1}{3}$. Find the fraction.

II. AGE RELATED QUESTIONS

1. Ten years hence, a man's age will be twice the age of his son. Ten years ago, man was four times as old as his son. Find their present ages.
2. A man's age is three times the sum of the ages of his two sons. After 5 years his age will be twice the sum of the ages of his two sons. Find the age of the man.
3. If twice the son's age in years is added to the mother's age, the sum is 70 years. But if twice the mother's age is added to the son's age, the sum is 95 years. Find the age of the mother and her son.
4. Five years ago Nuri was thrice old as Sonu. Ten years later, Nuri will be twice as old as Sonu. Find the present age of Nuri and Sonu.

5. The present age of a woman is 3 years more than three times the age of her daughter. Three years hence, the woman's age will be 10 years more than twice the age of her daughter. Find their present ages.
6. Two years ago, a man was 5 times as old as his son. Two years later his age will be 8 more than three times the age of the son. Find the present ages of the man and his son.
7. I am three times as old as my son. Five years later, I shall be two and a half times as old as my son. How old am I and how old is my son?
8. A and B are friends and their ages differ by 2 years. A's father D is twice as old as A and B is twice as old as his sister C. The age of D and C differ by 40 years. Find the ages of A and B.
9. The ages of two friends Ani and Biju differ by 3 years. Ani's father Dharam is twice as old as Ani and Biju is twice as old as his sister Cathy. The ages of Cathy and Dharam differ by 30 years. Find the ages of Ani and Biju.
10. Five years hence, the age of Jacob will be three times that of his son. Five years ago, Jacob's age was seven times that of his son. What are their present ages?
11. A father is three times as old as his son. In 12 years time, he will be twice as old as his son. Find their present ages.

III. SPEED, DISTANCE AND TIME RELATED QUESTIONS

1. A boat goes 30 km upstream and 44 km downstream in 10 hours. In 13 hours, it can go 40 km upstream and 55 km down-stream. Determine the speed of the stream and that of the boat in still water.
2. Places A and B are 100 km apart on a highway. One car starts from A and another from B at the same time. If the cars travel in the same direction at different speeds, they meet in 5 hours. If they travel towards each other, they meet in 1 hour. What are the speeds of the two cars?
3. Points A and B are 90 km apart from each other on a highway. A car starts from A and another from B at the same time. If they go in the same direction they meet in 9 hours and if they go in opposite directions they meet in $\frac{9}{4}$ hours. Find their speeds.
4. A train covered a certain distance at a uniform speed. If the train would have been 10 km/h faster, it would have taken 2 hours less than the scheduled time. And, if the train were slower by 10 km/h; it would have taken 3 hours more than the scheduled time. Find the distance covered by the train.
5. Ritu can row downstream 20 km in 2 hours, and upstream 4 km in 2 hours. Find her speed of rowing in still water and the speed of the current.
6. Roohi travels 300 km to her home partly by train and partly by bus. She takes 4 hours if she travels 60 km by train and the remaining by bus. If she travels 100 km by train and the remaining by bus, she takes 10 minutes longer. Find the speed of the train and the bus separately.

7. A boat goes 30 km upstream and 44 km downstream in 10 hours. In 13 hours, it can go 40 km upstream and 55 km down-stream. Determine the speed of the stream and that of the boat in still water.
8. A man travels 370 km partly by train and partly by car. If he covers 250 km by train and the rest by car, it takes him 4 hours. But if he travels 130 km by train and the rest by car, he takes 18 minutes longer. Find the speed of the train and that of the car.
9. A boat covers 32 km upstream and 36 km downstream in 7 hours. In 9 hours, it can cover 40 km upstream and 48 km down-stream. Find the speed of the stream and that of the boat in still water.
10. Two places A and B are 120 km apart on a highway. A car starts from A and another from B at the same time. If the cars move in the same direction at different speeds, they meet in 6 hours. If they travel towards each other, they meet in 1 hours 12 minutes. Find the speeds of the two cars.

IV. GEOMETRICAL FIGURES RELATED QUESTIONS

1. The area of a rectangle gets reduced by 9 square units, if its length is reduced by 5 units and breadth is increased by 3 units. If we increase the length by 3 units and the breadth by 2 units, the area increases by 67 square units. Find the dimensions of the rectangle.
2. The length of a room exceeds its breadth by 3 metres. If the length is increased by 3 metres and the breadth is decreased by 2 metres, the area remains the same. Find the length and the breadth of the room.
3. The area of a rectangle gets reduced by 8m^2 , if its length is reduced by 5m and breadth is increased by 3m. If we increase the length by 3m and the breadth by 2m, the area increases by 74m^2 . Find the length and the breadth of the rectangle.
4. In a $\triangle ABC$, $\angle C = 3\angle B = 2(\angle A + \angle B)$. Find the angles.
5. Find the four angles of a cyclic quadrilateral ABCD in which $\angle A = (2x - 1)^\circ$, $\angle B = (y + 5)^\circ$, $\angle C = (2y + 15)^\circ$ and $\angle D = (4x - 7)^\circ$.
6. The area of a rectangle remains the same if the length is increased by 7m and the breadth is decreased by 3m. The area remains unaffected if the length is decreased by 7m and the breadth is increased by 5m. Find the dimensions of the rectangle.
7. The larger of two supplementary angles exceeds the smaller by 18 degrees. Find them.
8. In a $\triangle ABC$, $\angle A = x^\circ$, $\angle B = (3x - 2)^\circ$, $\angle C = y^\circ$. Also, $\angle C - \angle B = 9^\circ$. Find the three angles.
9. Half the perimeter of a rectangular garden, whose length is 4 m more than its width, is 36 m. Find the dimensions of the garden.
10. ABCD is a cyclic quadrilateral. Find the angles of the cyclic quadrilateral.

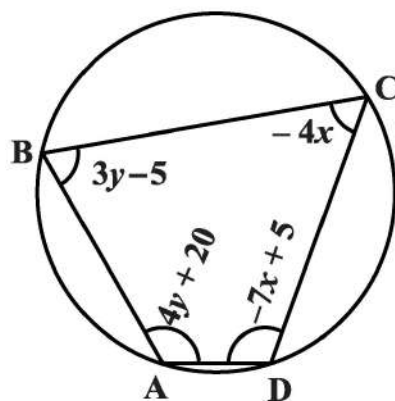

V. TIME AND WORK RELATED QUESTIONS

1. 2 men and 7 boys can do a piece of work in 4 days. The same work is done in 3 days by 4 men and 4 boys. How long would it take one man and one boy to do it alone.
2. 2 women and 5 men can together finish an embroidery work in 4 days, while 3 women and 6 men can finish it in 3 days. Find the time taken by 1 woman alone to finish the work, and also that taken by 1 man alone.
3. 8 men and 12 boys can finish a piece of work in 10 days while 6 men and 8 boys finish it in 14 days. Find the time taken by one man alone and by one boy alone to finish the work.
4. 8 men and 12 boys can finish a piece of work in 5 days while 6 men and 8 boys finish it in 7 days. Find the time taken by 1 man alone and by 1 boy alone to finish the work.
5. 2 men and 5 boys can do a piece of work in 4 days. The same work is done by 3 men and 6 boys in 3 days. . Find the time taken by 1 man alone and by 1 boy alone to finish the work.

VI. REASONING BASED QUESTIONS

1. One says, "Give me a hundred, friend! I shall then become twice as rich as you". The other replies, "If you give me ten, I shall be six times as rich as you". Tell me what is the amount of their (respective) capital?
2. The students of a class are made to stand in rows. If 3 students are extra in a row, there would be 1 row less. If 3 students are less in a row, there would be 2 rows more. Find the number of students in the class.
3. Yash scored 40 marks in a test, getting 3 marks for each right answer and losing 1 mark for each wrong answer. Had 4 marks been awarded for each correct answer and 2 marks been deducted for each incorrect answer, then Yash would have scored 50 marks. How many questions were there in the test?
4. A part of monthly hostel charges is fixed and the remaining depends on the number of days one has taken food in the mess. When a student A takes food for 20 days she has to pay Rs 1000 as hostel charges whereas a student B, who takes food for 26 days, pays Rs 1180 as hostel charges. Find the fixed charges and the cost of food per day.
5. From a bus stand in Bangalore , if we buy 2 tickets to Malleswaram and 3 tickets to Yeshwanthpur, the total cost is Rs 46; but if we buy 3 tickets to Malleswaram and 5 tickets to Yeshwanthpur the total cost is Rs 74. Find the fares from the bus stand to Malleswaram, and to Yeshwanthpur.
6. The cost of 5 oranges and 3 apples is Rs 35 and the cost of 2 oranges and 4 apples is Rs 28. Find the cost of an orange and an apple.
7. A lending library has a fixed charge for the first three days and an additional charge for each day thereafter. Saritha paid Rs 27 for a book kept for seven days, while Susy paid Rs 21 for the book she kept for five days. Find the fixed charge and the charge for each extra day.

8. Meena went to a bank to withdraw Rs 2000. She asked the cashier to give her Rs 50 and Rs 100 notes only. Meena got 25 notes in all. Find how many notes of Rs 50 and Rs 100 she received.
9. The ratio of incomes of two persons is $9 : 7$ and the ratio of their expenditures is $4 : 3$. If each of them manages to save Rs 2000 per month, find their monthly incomes.
10. The taxi charges in a city consist of a fixed charge together with the charge for the distance covered. For a distance of 10 km, the charge paid is Rs 105 and for a journey of 15 km, the charge paid is Rs 155. What are the fixed charges and the charge per km? How much does a person have to pay for travelling a distance of 25 km?
11. The coach of a cricket team buys 7 bats and 6 balls for Rs 3800. Later, she buys 3 bats and 5 balls for Rs 1750. Find the cost of each bat and each ball.
12. The cost of 2 pencils and 3 erasers is Rs 9 and the cost of 4 pencils and 6 erasers is Rs 18. Find the cost of each pencil and each eraser.
13. 5 pencils and 7 pens together cost Rs 50, whereas 7 pencils and 5 pens together cost Rs 46. Find the cost of one pencil and that of one pen.
14. The students of a class are made to stand in rows. If 4 students are extra in a row, there would be 2 rows less. If 4 students are less in a row, there would be 4 rows more. Find the number of students in the class.
15. A and B each has some money. If A gives Rs. 30 to B then B will have twice the money left with A. But if B gives Rs. 10 to A then A will have thrice as much as is left with B. How much money does each have?

CLASS X : CHAPTER - 4 QUADRATIC EQUATIONS

IMPORTANT FORMULAS & CONCEPTS

POLYNOMIALS

An algebraic expression of the form $p(x) = a_0 + a_1x + a_2x^2 + a_3x^3 + \dots + a_nx^n$, where $a \neq 0$, is called a polynomial in variable x of degree n .

Here, $a_0, a_1, a_2, a_3, \dots, a_n$ are real numbers and each power of x is a non-negative integer.

e.g. $3x^2 - 5x + 2$ is a polynomial of degree 2.

$3\sqrt{x} + 2$ is not a polynomial.

➤ If $p(x)$ is a polynomial in x , the highest power of x in $p(x)$ is called **the degree of the polynomial** $p(x)$. For example, $4x + 2$ is a polynomial in the variable x of degree 1, $2y^2 - 3y + 4$ is a polynomial in the variable y of degree 2,

- ❖ A polynomial of degree 0 is called a constant polynomial.
- ❖ A polynomial $p(x) = ax + b$ of degree 1 is called a linear polynomial.
- ❖ A polynomial $p(x) = ax^2 + bx + c$ of degree 2 is called a quadratic polynomial.
- ❖ A polynomial $p(x) = ax^3 + bx^2 + cx + d$ of degree 3 is called a cubic polynomial.
- ❖ A polynomial $p(x) = ax^4 + bx^3 + cx^2 + dx + e$ of degree 4 is called a bi-quadratic polynomial.

QUADRATIC EQUATION

A polynomial $p(x) = ax^2 + bx + c$ of degree 2 is called a quadratic polynomial, then $p(x) = 0$ is known as quadratic equation.

e.g. $2x^2 - 3x + 2 = 0$, $x^2 + 5x + 6 = 0$ are quadratic equations.

METHODS TO FIND THE SOLUTION OF QUADRATIC EQUATIONS

Three methods to find the solution of quadratic equation:

1. Factorisation method
2. Method of completing the square
3. Quadratic formula method

FACTORISATION METHOD

Steps to find the solution of given quadratic equation by factorisation

- Firstly, write the given quadratic equation in standard form $ax^2 + bx + c = 0$.
- Find two numbers α and β such that sum of α and β is equal to b and product of α and β is equal to ac .
- Write the middle term bx as $\alpha x + \beta x$ and factorise it by splitting the middle term and let factors are $(x + p)$ and $(x + q)$ i.e. $ax^2 + bx + c = 0 \Rightarrow (x + p)(x + q) = 0$
- Now equate each factor to zero and find the values of x .
- These values of x are the required roots/solutions of the given quadratic equation.

METHOD OF COMPLETING THE SQUARE

Steps to find the solution of given quadratic equation by Method of completing the square:

- Firstly, write the given quadratic equation in standard form $ax^2 + bx + c = 0$.
- Make coefficient of x^2 unity by dividing all by a then we get

$$x^2 + \frac{b}{a}x + \frac{c}{a} = 0$$

- Shift the constant on RHS and add square of half of the coefficient of x i.e. $\left(\frac{b}{2a}\right)^2$ on both sides.

$$x^2 + \frac{b}{a}x = -\frac{c}{a} \Rightarrow x^2 + 2\left(\frac{b}{2a}\right)x + \left(\frac{b}{2a}\right)^2 = -\frac{c}{a} + \left(\frac{b}{2a}\right)^2$$

- Write LHS as the perfect square of a binomial expression and simplify RHS.

$$\left(x + \frac{b}{2a}\right)^2 = \frac{b^2 - 4ac}{4a^2}$$

- Take square root on both sides

$$x + \frac{b}{2a} = \pm \sqrt{\frac{b^2 - 4ac}{4a^2}}$$

- Find the value of x by shifting the constant term on RHS i.e. $x = \pm \sqrt{\frac{b^2 - 4ac}{4a^2}} - \frac{b}{2a}$

QUADRATIC FORMULA METHOD

Steps to find the solution of given quadratic equation by quadratic formula method:

- Firstly, write the given quadratic equation in standard form $ax^2 + bx + c = 0$.
- Write the values of a, b and c by comparing the given equation with standard form.
- Find discriminant $D = b^2 - 4ac$. If value of D is negative, then is no real solution i.e. solution does not exist. If value of $D \geq 0$, then solution exists follow the next step.
- Put the value of a, b and D in quadratic formula $x = \frac{-b \pm \sqrt{D}}{2a}$ and get the required roots/solutions.

NATURE OF ROOTS

The roots of the quadratic equation $ax^2 + bx + c = 0$ by quadratic formula are given by

$$x = \frac{-b \pm \sqrt{b^2 - 4ac}}{2a} = \frac{-b \pm \sqrt{D}}{2a}$$

where $D = b^2 - 4ac$ is called discriminant. The nature of roots depends upon the value of discriminant D. There are three cases –

Case – I

When $D > 0$ i.e. $b^2 - 4ac > 0$, then the quadratic equation has two distinct roots.

$$\text{i.e. } x = \frac{-b + \sqrt{D}}{2a} \text{ and } \frac{-b - \sqrt{D}}{2a}$$

Case – II

When $D = 0$, then the quadratic equation has two equal real roots.

$$\text{i.e. } x = \frac{-b}{2a} \text{ and } \frac{-b}{2a}$$

Case – III

When $D < 0$ then there is no real roots exist.

MCQ WORKSHEET-I
CLASS X: CHAPTER – 4
QUADRATIC EQUATIONS

1. The roots of the equation $x^2 + 7x + 10 = 0$ are
(a) 2 and 5 (b) -2 and 5 (c) -2 and -5 (d) 2 and -5
 2. If α, β are the roots of the quadratic equation $x^2 + x + 1 = 0$, then $\frac{1}{\alpha} + \frac{1}{\beta}$
(a) 0 (b) 1 (c) -1 (d) none of these
 3. If the equation $x^2 + 4x + k = 0$ has real and distinct roots then
(a) $k < 4$ (b) $k > 4$ (c) $k \leq 4$ (d) $k \geq 4$
 4. If the equation $x^2 - ax + 1 = 0$ has two distinct roots then
(a) $|a| = 2$ (b) $|a| < 2$ (c) $|a| > 2$ (d) none of these
 5. If the equation $9x^2 + 6kx + 4 = 0$ has equal roots then the roots are both equal to
(a) $\pm \frac{2}{3}$ (b) $\pm \frac{3}{2}$ (c) 0 (d) ± 3
 6. If the equation $(a^2 + b^2)x^2 - 2b(a + c)x + b^2 + c^2 = 0$ has equal roots then
(a) $2b = a + c$ (b) $b^2 = ac$ (c) $b = \frac{2ac}{a + c}$ (d) $b = ac$
 7. If the equation $x^2 - bx + 1 = 0$ has two distinct roots then
(a) $-3 < b < 3$ (b) $-2 < b < 2$ (c) $b > 2$ (d) $b < -2$
 8. If $x = 1$ is a common root of the equations $ax^2 + ax + 3 = 0$ and $x^2 + x + b = 0$ then $ab =$
(a) 6 (b) 3 (c) -3 (d) $\frac{7}{2}$
 9. If p and q are the roots of the equation $x^2 - px + q = 0$, then
(a) $p = 1, q = -2$ (b) $p = -2, q = 0$ (c) $b = 0, q = 1$ (d) $p = -2, q = 1$
 10. If the equation $ax^2 + bx + c = 0$ has equal roots then $c =$
(a) $\frac{-b}{2a}$ (b) $\frac{b}{2a}$ (c) $\frac{-b^2}{4a}$ (d) $\frac{b^2}{4a}$
 11. If the equation $ax^2 + 2x + a = 0$ has two distinct roots if
(a) $a = \pm 1$ (b) $a = 0$ (c) $a = 0, 1$ (d) $a = -1, 0$
 12. The possible value of k for which the equation $x^2 + kx + 64 = 0$ and $x^2 - 8x + k = 0$ will both have real roots, is
(a) 4 (b) 8 (c) 12 (d) 16
-

MCQ WORKSHEET-II
CLASS X: CHAPTER – 4
QUADRATIC EQUATIONS

1. The value of $\sqrt{6+\sqrt{6+\sqrt{6+\dots}}}$ is
(a) 4 (b) 3 (c) -2 (d) $\frac{7}{2}$
 2. If 2 is the root of the equation $x^2 + bx + 12 = 0$ and the equation $x^2 + bx + q = 0$ has equal roots then $q =$
(a) 8 (b) 16 (c) -8 (d) -16
 3. If the equation $(a^2 + b^2)x^2 - 2(ac + bd)x + c^2 + d^2 = 0$ has equal roots then
(a) $ab = cd$ (b) $ad = bc$ (c) $ad = \sqrt{bc}$ (d) $ab = \sqrt{cd}$
 4. If a and b can take values 1, 2, 3, 4. Then the number of the equations of the form $ax^2 + bx + c = 0$ having real roots is
(a) 6 (b) 7 (c) 10 (d) 12
 5. The number of quadratic equations having real roots and which do not change by squaring their roots is
(a) 4 (b) 3 (c) 2 (d) 1
 6. If one of the roots of the quadratic equation $(k^2 + 4)x^2 + 13x + 4k$ is reciprocal of the other then $k =$
(a) 2 (b) 1 (c) -1 (d) -2
 7. If α, β are the roots of the quadratic equation $4x^2 + 3x + 7 = 0$, then $\frac{1}{\alpha} + \frac{1}{\beta}$
(a) $\frac{7}{3}$ (b) $-\frac{7}{3}$ (c) $\frac{3}{7}$ (d) $-\frac{3}{7}$
 8. If α, β are the roots of the quadratic equation $x^2 - p(x + 1) - c = 0$, then $(\alpha + 1)(\beta + 1) =$
(a) $c - 1$ (b) $1 - c$ (c) c (d) $1 + c$
 9. Find the values of k for which the quadratic equation $2x^2 + kx + 3 = 0$ has real equal roots.
(a) $\pm 2\sqrt{6}$ (b) $2\sqrt{6}$ (c) 0 (d) ± 2
 10. Find the values of k for which the quadratic equation $kx(x - 3) + 9 = 0$ has real equal roots.
(a) $k = 0$ or $k = 4$ (b) $k = 1$ or $k = 4$ (c) $k = -3$ or $k = 3$ (d) $k = -4$ or $k = 4$
 11. Find the values of k for which the quadratic equation $4x^2 - 3kx + 1 = 0$ has real and equal roots.
(a) $\pm \frac{4}{3}$ (b) $\pm \frac{2}{3}$ (c) ± 2 (d) none of these
 12. Find the values of k for which the quadratic equation $(k - 12)x^2 + 2(k - 12)x + 2 = 0$ has real and equal roots.
(a) $k = 0$ or $k = 14$ (b) $k = 12$ or $k = 24$ (c) $k = 14$ or $k = 12$ (d) $k = 1$ or $k = 12$
-

MCQ WORKSHEET-III
CLASS X: CHAPTER – 4
QUADRATIC EQUATIONS

1. The value of k for which equation $9x^2 + 8kx + 8 = 0$ has equal roots is:
(a) only 3 (b) only -3 (c) ± 3 (d) 9
 2. Which of the following is not a quadratic equation?
(a) $x - \frac{3}{x} = 4$ (b) $3x - \frac{5}{x} = x^2$ (c) $x + \frac{1}{x} = 3$ (d) $x^2 - 3 = 4x^2 - 4x$
 3. Which of the following is a solution of the quadratic equation $2x^2 + x - 6 = 0$?
(a) $x = 2$ (b) $x = -12$ (c) $x = \frac{3}{2}$ (d) $x = -3$
 4. The value of k for which $x = -2$ is a root of the quadratic equation $kx^2 + x - 6 = 0$
(a) -1 (b) -2 (c) 2 (d) $-\frac{3}{2}$
 5. The value of p so that the quadratic equation $x^2 + 5px + 16 = 0$ has no real root, is
(a) $p > 8$ (b) $p < 5$ (c) $-\frac{8}{5} < x < \frac{8}{5}$ (d) $-\frac{8}{5} \leq x < 0$
 6. If $px^2 + 3qx + q = 0$ has two roots $x = -1$ and $x = -2$, the value of $q - p$ is
(a) -1 (b) -2 (c) 1 (d) 2
 7. The common root of the quadratic equation $x^2 - 3x + 2 = 0$ and $2x^2 - 5x + 2 = 0$ is:
(a) $x = 2$ (b) $x = -2$ (c) $x = \frac{1}{2}$ (d) $x = 1$
 8. If $x^2 - 5x + 1 = 0$, the value of $\left(x + \frac{1}{x}\right)$ is:
(a) -5 (b) -2 (c) 5 (d) 3
 9. If $a - 3 = \frac{10}{a}$, the value of a are
(a) -5, 2 (b) 5, -2 (c) 5, 2 (d) 5, 0
 10. If the roots of the quadratic equation $kx^2 + (a + b)x + ab = 0$ are $(-1, -b)$, the value of k is:
(a) -1 (b) -2 (c) 1 (d) 2
 11. The quadratic equation with real coefficient whose one root is $2 + \sqrt{3}$ is:
(a) $x^2 - 2x + 1 = 0$ (b) $x^2 - 4x + 1 = 0$ (c) $x^2 - 4x + 3 = 0$ (d) $x^2 - 4x + 4 = 0$
 12. If the difference of roots of the quadratic equation $x^2 + kx + 12 = 0$ is 1, the positive value of k is:
(a) -7 (b) 7 (c) 4 (d) 8
-

MCQ WORKSHEET-IV
CLASS X: CHAPTER – 4
QUADRATIC EQUATIONS

1. Find the values of k for which the quadratic equation $k^2x^2 - 2(k - 1)x + 4 = 0$ has real and equal roots.
(a) $k = 0$ or $k = \frac{1}{3}$ (b) $k = 1$ or $k = \frac{1}{3}$ (c) $k = -1$ or $k = \frac{1}{3}$ (d) $k = -3$ or $k = \frac{1}{3}$
 2. If -4 is a root of the equation $x^2 + px - 4 = 0$ and the equation $x^2 + px + q = 0$ has equal roots, find the value of p and q.
(a) $p = 3, q = 9$ (b) $p = 9, q = 3$ (c) $p = 3, q = \frac{4}{9}$ (d) $p = 3, q = \frac{9}{4}$
 3. If the roots of the equation $(a - b)x^2 + (b - c)x + (c - a) = 0$ are equal, then $b + c =$
(a) $2a$ (b) $2bc$ (c) $2c$ (d) none of these
 4. Find the positive value of k for which the equations $x^2 + kx + 64 = 0$ and $x^2 - 8x + k = 0$ will have real roots.
(a) 8 (b) 16 (c) -8 (d) -16
 5. Find the positive value of k for which the equation $kx^2 - 6x - 2 = 0$ has real roots
(a) $k \leq \frac{-9}{2}$ (b) $k \geq \frac{-9}{2}$ (c) $k > \frac{-9}{2}$ (d) $k < \frac{-9}{2}$
 6. Find the positive value of k for which the equation $3x^2 + 2x + k = 0$ has real roots
(a) $k \geq \frac{1}{3}$ (b) $k \leq \frac{1}{3}$ (c) $k > \frac{1}{3}$ (d) $k < \frac{1}{3}$
 7. Find the positive value of k for which the equation $2x^2 + kx + 2 = 0$ has real roots
(a) $k \geq 4$ (b) $k \leq -4$ (c) both (a) and (c) (d) none of these.
 8. The sum of a number and its reciprocal is $\frac{10}{3}$. Find the number.
(a) 3 (b) $\frac{1}{3}$ (c) both (a) and (c) (d) none of these
 9. Divide 12 into two parts such that the sum of their squares is 74.
(a) 7 and 5 (b) 8 and 4 (c) 10 and 2 (d) none of these
 10. The sum of the squares of two consecutive natural numbers is 421. Find the numbers.
(a) 14 and 5 (b) 14 and 15 (c) 10 and 5 (d) none of these
 11. The sum of two numbers is 15 and the sum of their reciprocals is $\frac{3}{10}$. Find the numbers.
(a) 14 and 5 (b) 14 and 15 (c) 10 and 5 (d) none of these
 12. Divide 12 into two parts such that their product is 32.
(a) 7 and 5 (b) 8 and 4 (c) 10 and 2 (d) none of these
-

PRACTICE QUESTIONS
CLASS X : CHAPTER - 4
QUADRATIC EQUATIONS
FACTORISATION METHOD

Solve the following quadratic equations:

1. $x^2 + 11x + 30 = 0$

2. $x^2 + 18x + 32 = 0$

3. $x^2 + 7x - 18 = 0$

4. $x^2 + 5x - 6 = 0$

5. $y^2 - 4y + 3 = 0$

6. $x^2 - 21x + 108 = 0$

7. $x^2 - 11x - 80 = 0$

8. $x^2 - x - 156 = 0$

9. $z^2 - 32z - 105 = 0$

10. $40 + 3x - x^2 = 0$

11. $6 - x - x^2 = 0$

12. $7x^2 + 49x + 84 = 0$

13. $m^2 + 17mn - 84n^2 = 0$

14. $5x^2 + 16x + 3 = 0$

15. $6x^2 + 17x + 12 = 0$

16. $9x^2 + 18x + 8 = 0$

17. $14x^2 + 9x + 1 = 0$

18. $2x^2 + 3x - 90 = 0$

19. $2x^2 + 11x - 21 = 0$

20. $3x^2 - 14x + 8 = 0$

21. $18x^2 + 3x - 10 = 0$

22. $15x^2 + 2x - 8 = 0$

23. $6x^2 + 11x - 10 = 0$

24. $30x^2 + 7x - 15 = 0$

25. $24x^2 - 41x + 12 = 0$

26. $2x^2 - 7x - 15 = 0$

27. $6x^2 + 11x - 10 = 0$

28. $10x^2 - 9x - 7 = 0$

29. $5x^2 - 16x - 21 = 0$

30. $2x^2 - x - 21 = 0$

31. $15x^2 - x - 28 = 0$

32. $8a^2 - 27ab + 9b^2 = 0$

33. $5x^2 + 33xy - 14y^2 = 0$

34. $3x^3 - x^2 - 10x = 0$

35. $x^2 + 9x + 18 = 0$

36. $x^2 + 5x - 24 = 0$

37. $x^2 - 4x - 21 = 0$

38. $6x^2 + 7x - 3 = 0$

39. $2x^2 - 7x - 39 = 0$

40. $9x^2 - 22x + 8 = 0$

41. $6x^2 + 40 = 31x$

42. $36x^2 - 12ax + (a^2 - b^2) = 0$

43. $8x^2 - 22x - 21 = 0$

44. $2x^2 - x + \frac{1}{8} = 0$

45. $4\sqrt{3}x^2 + 5x - 2\sqrt{3} = 0$

PRACTICE QUESTIONS
CLASS X : CHAPTER - 4
QUADRATIC EQUATIONS
FACTORISATION METHOD

Solve the following by Factorisation method:

1. $\sqrt{2}x^2 + 7x + 5\sqrt{2} = 0$

2. $2x - \frac{3}{x} = 1$

3. $\frac{4}{x} - 3 = \frac{5}{2x+3}, x \neq 0, \frac{-3}{2}$

4. $\frac{x}{x+1} + \frac{x+1}{x} = \frac{34}{15}, x \neq -1 \text{ and } x \neq 0$

5. $\frac{x+3}{x+2} = \frac{3x-7}{2x-3}$

6. $\frac{x-1}{x-2} + \frac{x-3}{x-4} = 3\frac{1}{3} (x \neq 2, 4)$

7. $\frac{1}{a+b+x} = \frac{1}{a} + \frac{1}{b} + \frac{1}{x}, [x \neq 0, -(a+b)]$

8. $2\left(\frac{2x-1}{x+3}\right) - 3\left(\frac{x+3}{2x-1}\right) = 5, x \neq -3, \frac{1}{2}$

9. $5^{(x+1)} + 5^{(2-x)} = 5^3 + 1$

10. $5x - \frac{35}{x} = 18, x \neq 0$

11. $2^{2x} - 3 \cdot 2^{(x+2)} + 32 = 0$

12. $4^{(x+1)} + 4^{(1-x)} = 10$

13. $3^{(x+2)} + 3^{-x} = 10$

14. $10x - \frac{1}{x} = 3$

15. $\frac{2}{x^2} - \frac{5}{x} + 2 = 0$

16. $\sqrt{3}x^2 + 11x + 6\sqrt{3} = 0$

17. $4\sqrt{3}x^2 + 5x - 2\sqrt{3} = 0$

18. $3\sqrt{7}x^2 + 4x - \sqrt{7} = 0$

19. $\sqrt{7}x^2 - 6x - 13\sqrt{7} = 0$

20. $4\sqrt{6}x^2 - 13x - 2\sqrt{6} = 0$

21. $x^2 - (1 + \sqrt{2})x + \sqrt{2} = 0$
22. $\left(\frac{4x-3}{2x+1}\right) - 10\left(\frac{2x+1}{4x-3}\right) = 3, \left(x \neq \frac{-1}{2}, \frac{3}{4}\right)$
23. $\left(\frac{x}{x+1}\right)^2 - 5\left(\frac{x}{x+1}\right) + 6 = 0, (x \neq -1)$
24. $2\left(\frac{2x-1}{x+3}\right) - 3\left(\frac{x+3}{2x-1}\right) = 5, \left(x \neq -3, \frac{1}{2}\right)$
25. $2\left(\frac{x-1}{x+3}\right) - 7\left(\frac{x+3}{x-1}\right) = 5, (x \neq -3, 1)$
26. $\frac{a}{x-b} + \frac{b}{x-a} = 2, (x \neq a, b)$
27. $\frac{a}{ax-1} + \frac{b}{bx-1} = a+b, \left(x \neq \frac{1}{a}, \frac{1}{b}\right)$
28. $\frac{x+3}{x-2} - \frac{1-x}{x} = \frac{17}{4}, (x \neq 0, 2)$
29. $\frac{2x}{x-4} + \frac{2x-5}{x-3} = \frac{25}{3}, (x \neq 4, 3)$
30. $\frac{1}{x-3} - \frac{1}{x+5} = \frac{1}{6}, (x \neq 3, -5)$
31. $\frac{1}{x-2} + \frac{2}{x-1} = \frac{6}{x}, (x \neq 2, 1)$
32. $\frac{1}{x+4} - \frac{1}{x-7} = \frac{11}{30}, (x \neq -4, 7)$
33. $\frac{1}{x-2} + \frac{1}{x-4} = \frac{4}{3}, (x \neq 2, 4)$
34. $\frac{x-3}{x+3} - \frac{x+3}{x-3} = 6\frac{6}{7}, (x \neq -3, 3)$
35. $\frac{2x}{x-3} + \frac{1}{2x+3} + \frac{3x+9}{(x-3)(2x+3)} = 0$
36. $x = \frac{1}{2 - \frac{1}{2 - \frac{1}{2-x}}}, x \neq 2$
37. $4x^2 - 2(a^2 + b^2)x + a^2b^2 = 0$
38. $9x^2 - 9(a+b)x + (2a^2 + 5ab + 2b^2) = 0$
39. $4x^2 - 4a^2x + (a^4 - b^4) = 0$

$$40. x^2 + \left(\frac{a+b}{a} + \frac{a}{a+b} \right) x + 1 = 0$$

$$41. x^2 + x - (a+1)(a+2) = 0$$

$$42. x^2 + 3x - (a^2 + a - 2) = 0$$

$$43. a^2 b^2 x^2 + b^2 x - a^2 x - 1 = 0$$

$$44. x + \frac{1}{x} = 25 \frac{1}{25}$$

$$45. (x-3)(x-4) = \frac{34}{(33)^2}$$

$$46. x^2 + \left(a + \frac{1}{a} \right) x + 1 = 0$$

$$47. (a+b)^2 x^2 - 4abx - (a-b)^2 = 0$$

$$48. 7x + \frac{3}{x} = 35 \frac{3}{5}$$

$$49. \frac{x-a}{x-b} + \frac{x-b}{x-a} = \frac{a}{b} + \frac{b}{a}$$

$$50. (x-5)(x-6) = \frac{25}{(24)^2}$$



PRACTICE QUESTIONS
CLASS X : CHAPTER - 4
QUADRATIC EQUATIONS
METHOD OF COMPLETING THE SQUARE

Solve the following quadratic equation (if they exist) by the method of completing the square:

1. $8x^2 - 22x - 21 = 0$
2. $2x^2 - x + \frac{1}{8} = 0$
3. $4\sqrt{3}x^2 + 5x - 2\sqrt{3} = 0$
4. $\sqrt{2}x^2 + 7x + 5\sqrt{2} = 0$
5. $9x^2 - 15x + 6 = 0$
6. $2x^2 - 5x + 3 = 0$
7. $4x^2 + 3x + 5 = 0$
8. $5x^2 - 6x - 2 = 0$
9. $4x^2 + 4bx - (a^2 - b^2) = 0$
10. $a^2x^2 - 3abx + 2b^2 = 0$
11. $x^2 - (\sqrt{3} + 1)x + \sqrt{3} = 0$
12. $x^2 - 4ax + 4a^2 - b^2 = 0$
13. $x^2 - (\sqrt{2} + 1)x + \sqrt{2} = 0$
14. $\sqrt{3}x^2 + 10x + 7\sqrt{3} = 0$
15. $\sqrt{2}x^2 - 3x - 2\sqrt{2} = 0$
16. $4x^2 + 4\sqrt{3}x + 3 = 0$
17. $2x^2 + x + 4 = 0$
18. $2x^2 + x - 4 = 0$
19. $3x^2 + 11x + 10 = 0$
20. $2x^2 - 7x + 3 = 0$
21. $5x^2 - 19x + 17 = 0$
22. $2x^2 + x - 6 = 0$
23. $2x^2 - 9x + 7 = 0$
24. $6x^2 + 7x - 10 = 0$
25. $x^2 - 4\sqrt{2}x + 6 = 0$

PRACTICE QUESTIONS
CLASS X : CHAPTER - 4
QUADRATIC EQUATIONS
METHOD OF QUADRATIC FORMULA

Show that each of the following equations has real roots, and solve each by using the quadratic formula:

1. $9x^2 + 7x - 2 = 0$

2. $x^2 + 6x + 6 = 0$

3. $2x^2 + 5\sqrt{3}x + 6 = 0$

4. $36x^2 - 12ax + (a^2 - b^2) = 0$

5. $a^2b^2x^2 - (4b^4 - 3a^4)x - 12a^2b^2 = 0$

6. $(a + b)^2x^2 - 4abx - (a - b)^2 = 0$

7. $4x^2 - 2(a^2 + b^2)x + a^2b^2 = 0$

8. $9x^2 - 9(a + b)x + (2a^2 + 5ab + 2b^2) = 0$

9. $4x^2 - 4a^2x + (a^4 - b^4) = 0$

10. $\sqrt{3}x^2 + 11x + 6\sqrt{3} = 0$

11. $4\sqrt{3}x^2 + 5x - 2\sqrt{3} = 0$

12. $3\sqrt{7}x^2 + 4x - \sqrt{7} = 0$

13. $\sqrt{7}x^2 - 6x - 13\sqrt{7} = 0$

14. $4\sqrt{6}x^2 - 13x - 2\sqrt{6} = 0$

15. $x^2 - (1 + \sqrt{2})x + \sqrt{2} = 0$

16. $2x^2 + 5\sqrt{3}x + 6 = 0$

17. $x^2 - 2x + 1 = 0$

18. $3x^2 + 2\sqrt{5}x - 5 = 0$

19. $3a^2x^2 + 8abx + 4b^2 = 0, a \neq 0$

20. $2x^2 - 2\sqrt{6}x + 3 = 0$

21. $3x^2 - 2x + 2 = 0$

22. $\sqrt{3}x^2 + 10x - 8\sqrt{3} = 0$

23. $x^2 + x + 2 = 0$

24. $16x^2 = 24x + 1$

25. $25x^2 + 20x + 7 = 0$

26. $6x^2 + x - 2 = 0$

27. $x^2 + 5x + 5 = 0$

28. $p^2x^2 + (p^2 - q^2)x - q^2 = 0$

29. $abx^2 + (b^2 - ac)x - bc = 0$

30. $x^2 - 2ax + (a^2 - b^2) = 0$

31. $12abx^2 - (9a^2 - 8b^2)x - 6ab = 0$

32. $24x^2 - 41x + 12 = 0$

33. $2x^2 - 7x - 15 = 0$

34. $6x^2 + 11x - 10 = 0$

35. $10x^2 - 9x - 7 = 0$

36. $x^2 - x - 156 = 0$

37. $z^2 - 32z - 105 = 0$

38. $40 + 3x - x^2 = 0$

39. $6 - x - x^2 = 0$

40. $7x^2 + 49x + 84 = 0$

PRACTICE QUESTIONS
CLASS X : CHAPTER - 4
QUADRATIC EQUATIONS
NATURE OF ROOTS

1. Find the value of k for which the quadratic equation $2x^2 + kx + 3 = 0$ has two real equal roots.
2. Find the value of k for which the quadratic equation $kx(x - 3) + 9 = 0$ has two real equal roots.
3. Find the value of k for which the quadratic equation $4x^2 - 3kx + 1 = 0$ has two real equal roots..
4. If -4 is a root of the equation $x^2 + px - 4 = 0$ and the equation $x^2 + px + q = 0$ has equal roots, find the value of p and q .
5. If -5 is a root of the equation $2x^2 + px - 15 = 0$ and the equation $p(x^2 + x) + k = 0$ has equal roots, find the value of k .
6. Find the value of k for which the quadratic equation $(k - 12)x^2 + 2(k - 12)x + 2 = 0$ has two real equal roots..
7. Find the value of k for which the quadratic equation $k^2x^2 - 2(k - 1)x + 4 = 0$ has two real equal roots..
8. If the roots of the equation $(a - b)x^2 + (b - c)x + (c - a) = 0$ are equal, prove that $b + c = 2a$.
9. Prove that both the roots of the equation $(x - a)(x - b) + (x - b)(x - c) + (x - c)(x - a) = 0$ are real but they are equal only when $a = b = c$.
10. Find the positive value of k for which the equation $x^2 + kx + 64 = 0$ and $x^2 - 8x + k = 0$ will have real roots.
11. Find the value of k for which the quadratic equation $kx^2 - 6x - 2 = 0$ has two real roots.
12. Find the value of k for which the quadratic equation $3x^2 + 2x + k = 0$ has two real roots.
13. Find the value of k for which the quadratic equation $2x^2 + kx + 2 = 0$ has two real roots.
14. Show that the equation $3x^2 + 7x + 8 = 0$ is not true for any real value of x .
15. Show that the equation $2(a^2 + b^2)x^2 + 2(a + b)x + 1 = 0$ has no real roots, when $a \neq b$.
16. Find the value of k for which the quadratic equation $kx^2 + 2x + 1 = 0$ has two real and distinct roots.
17. Find the value of p for which the quadratic equation $2x^2 + px + 8 = 0$ has two real and distinct roots.
18. If the equation $(1 + m^2)x^2 + 2mcx + (c^2 - a^2) = 0$ has equal roots, prove that $c^2 = a^2(1 + m^2)$.

19. If the roots of the equation $(c^2 - ab)x^2 - 2(a^2 - bc)x + (b^2 - ac) = 0$ are real and equal, show that either $a = 0$ or $(a^3 + b^3 + c^3) = 3abc$.
20. Find the value of k for which the quadratic equation $9x^2 + 8kx + 16 = 0$ has two real equal roots.
21. Find the value of k for which the quadratic equation $(k + 4)x^2 + (k+1)x + 1 = 0$ has two real equal roots.
22. Prove that the equation $x^2(a^2 + b^2) + 2x(ac + bd) + (c^2 + d^2) = 0$ has no real root, if $ad \neq bc$.
23. If the roots of the equation $x^2 + 2cx + ab = 0$ are real unequal, prove that the equation $x^2 - 2(a + b)x + a^2 + b^2 + 2c^2 = 0$ has no real roots.
24. Find the positive values of k for which the equation $x^2 + kx + 64 = 0$ and $x^2 - 8x + k = 0$ will both have real roots.
25. Find the value of k for which the quadratic equation $(k + 4)x^2 + (k + 1)x + 1 = 0$ has equal roots.
26. Find the value of k for which the quadratic equation $x^2 - 2(k + 1)x + k^2 = 0$ has real and equal roots.
27. Find the value of k for which the quadratic equation $k^2x^2 - 2(2k - 1)x + 4 = 0$ has real and equal roots.
28. Find the value of k for which the quadratic equation $(k + 1)x^2 - 2(k - 1)x + 1 = 0$ has real and equal roots.
29. Find the value of k for which the quadratic equation $(4 - k)x^2 + (2k + 4)x + (8k + 1) = 0$ has real and equal roots.
30. Find the value of k for which the quadratic equation $(2k + 1)x^2 + 2(k + 3)x + (k + 5) = 0$ has real and equal roots.
-

PRACTICE QUESTIONS
CLASS X : CHAPTER - 4
QUADRATIC EQUATIONS
WORD PROBLEMS CATEGORY WISE

VII. NUMBER BASED QUESTIONS

DIRECT QUESTIONS

1. The difference of two numbers is 5 and the difference of their reciprocals is $\frac{1}{10}$. Find the numbers.
2. Find two consecutive odd positive integers, sum of whose squares is 290.
3. The difference of the squares of two numbers is 45. The squares of the smaller number are 4 times the larger number. Find the numbers.
4. The sum of the squares of the two positive integers is 208. If the square of the larger number is 18 times the smaller number, find the numbers.
5. The denominator of a fraction is 3 more than its numerator. The sum of the fraction and its reciprocal is $2\frac{9}{10}$. Find the fraction.
6. The denominator of a fraction is one more than twice the numerator. The sum of the fraction and its reciprocal is $2\frac{16}{21}$. Find the fraction.
7. Two numbers differ by 3 and their product is 504. Find the numbers.
8. Find three consecutive positive integers such that the sum of the square of the first and the product of the other two is 154.
9. The sum of two numbers is 16 and the sum of their reciprocals is $\frac{1}{3}$. Find the numbers.
10. The sum of two numbers is 18 and the sum of their reciprocals is $\frac{1}{4}$. Find the numbers.
11. The sum of two numbers is 25 and the sum of their reciprocals is $\frac{3}{10}$. Find the numbers.
12. The sum of two numbers is 15 and the sum of their reciprocals is $\frac{3}{10}$. Find the numbers.
13. The sum of a number and its reciprocal is $3\frac{41}{80}$. Find the numbers.
14. The sum of the squares of three consecutive positive integers is 50. Find the integers.
15. Find two natural numbers, the sum of whose squares is 25 times their sum and also equal to 50 times their difference.

TWO-DIGIT PROBLEMS

1. A two digit number is such that the product of its digits is 12. When 36 is added to the number, the digits are reversed. Find the number.
2. A two digit number is such that the product of its digits is 8. When 54 is subtracted from the number, the digits are reversed. Find the number.
3. A two digit number is four times the sum and twice the product of its digits. Find the number
4. A two digit number is such that the product of its digits is 14. When 45 is added to the number, the digits interchange their places. Find the number.

5. A two digit number is such that the product of its digits is 18. When 63 is subtracted from the number, the digits interchange their places. Find the number.
6. A two digit number is four times the sum and three times the product of its digits. Find the number
7. A two digit number is such that the product of its digits is 8. When 18 is subtracted from the number, the digits are reversed. Find the number.
8. A two digit number is 4 times the sum of its digits and twice the product of its digits. Find the number.
9. A two digit number is 5 times the sum of its digits and is also equal to 5 more than twice the product of its digits. Find the number.
10. A two digit number is such that the product of its digits is 35. When 18 is added to the number, the digits interchange their places. Find the number.

VIII. AGE RELATED QUESTIONS

1. The sum of ages of a father and his son is 45 years. Five years ago, the product of their ages in years was 124. Find their present ages.
2. Seven years ago Varun's age was five times the square of Swati's age. Three years hence Swati's age will be two fifth of Varun's age. Find their present ages.
3. The product of Rohit's age five years ago with his age 9 years later is 15 in years. Find his present age.
4. The product of Archana's age five years ago with her age 8 years later is 30 in years. Find her present age.
5. The sum of the ages of a man and his son is 45 years. Five years ago, the product of their ages in years was four times the man's age at that time. Find their present ages.
6. The sum of the ages of a boy and his brother is 25 years and the product of their ages in years is 126. Find their ages.
7. The sum of the ages of a boy and his brother is 12 years and the sum of the square of their ages is 74 in years. Find their ages.
8. A boy is one year older than his friend. If the sum of the square of their ages is 421, find their ages.
9. The difference of the ages of a boy and his brother is 3 and the product of their ages in years is 504. Find their ages.
10. The sum of the ages of a boy and his brother is 57 years and the product of their ages in years is 782. Find their ages.

IX. SPEED, DISTANCE AND TIME RELATED QUESTIONS

1. A motor boat whose speed is 18 km/hr in still water takes 1 hour more to go 24 upstream than to return to the same point. Find the speed of the stream.
2. A motorboat whose speed is 9km/hr in still water, goes 15 km downstream and comes back in a total time of 3 hours 45 minutes. Find the speed of the stream.
3. A passenger train takes 2 hours less for a journey of 300 km if its speed is increased by 5 km/hr from its usual speed. Find its usual speed.
4. In a flight for 3000 km, an aircraft was slowed down due to bad weather. Its average speed for the trip was reduced by 100 km/hr and consequently time of flight increased by one hour. Find the original duration of flight.
5. A plane left 30 minutes later than the schedule time and in order to reach its destination 1500 km away in time it has to increase its speed by 250 km/hr from its usual speed. Find its usual speed.
6. An express train takes 1 hour less than a passenger train to travel 132 km between Mysore and Bangalore (without taking into consideration the time they stop at intermediate stations). If the

average speed of the express train is 11km/h more than that of the passenger train, find the average speed of the two trains.

7. A train travels 360 km at a uniform speed. If the speed had been 5 km/h more, it would have taken 1 hour less for the same journey. Find the speed of the train.
8. In a flight for 6000 km, an aircraft was slowed down due to bad weather. Its average speed for the trip was reduced by 400 km/hr and consequently time of flight increased by 30 minutes. Find the original duration of flight.
9. The time taken by a man to cover 300 km on a scooter was $1\frac{1}{2}$ hours more than the time taken by him during the return journey. If the speed in returning be 10 km/hr more than the speed in going, find its speed in each direction.
10. A motorboat whose speed is 15 km/hr in still water, goes 30 km downstream and comes back in a total time of 4 hours 30 minutes. Find the speed of the stream.
11. The speed of a boat in still water is 8 km/hr. It can go 15 km upstream and 22 km downstream in 5 hours. Find the speed of the stream.
12. A motor boat goes 10 km upstream and returns back to the starting point in 55 minutes. If the speed of the motor boat in still water is 22 km/hr, find the speed of the current.
13. A sailor can row a boat 8 km downstream and return back to the starting point in 1 hour 40 minutes. If the speed of the stream is 2 km/hr, find the speed of the boat in still water.
14. A train covers a distance of 90 km at a uniform speed. Had the speed been 15 km/hr more, it would have taken 30 minutes less for the journey. Find the original speed of the train.
15. The distance between Mumbai and Pune is 192 km. Travelling by the Deccan Queen, it takes 48 minutes less than another train. Calculate the speed of the Deccan Queen if the speeds of the two trains differ by 20 km/hr.
16. An aeroplane left 30 minutes later than its scheduled time and in order to reach its destination 1500 km away in time, it had to increase its speed by 250 km/hr from its usual speed. Determine its usual speed.

X. GEOMETRICAL FIGURES RELATED QUESTIONS

1. The sum of the areas of two squares is 640 m^2 . If the difference in their perimeters be 64 m, find the sides of the two squares.
2. The hypotenuse of a right triangle is $3\sqrt{10}$ cm. If the smaller side is tripled and the longer sides doubled, new hypotenuse will be $9\sqrt{5}$ cm. How long are the sides of the triangle?
3. A pole has to be erected at a point on the boundary of a circular park of diameter 13 metres in such a way that the differences of its distances from two diametrically opposite fixed gates A and B on the boundary is 7 metres. Is it possible to do so? If yes, at what distances from the two gates should the pole be erected?
4. The sum of the areas of two squares is 468 m^2 . If the difference of their perimeters is 24 m, find the sides of the two squares.
5. The hypotenuse of a right triangle is $3\sqrt{5}$ cm. If the smaller side is tripled and the longer sides doubled, new hypotenuse will be 15 cm. How long are the sides of the triangle?
6. The hypotenuse of right-angled triangle is 6 m more than twice the shortest side. If the third side is 2 m less than the hypotenuse, find the sides of the triangle.
7. The hypotenuse of a right triangle is 25 cm. The difference between the lengths of the other two sides of the triangle is 5 cm. Find the lengths of these sides.
8. The diagonal of a rectangular field is 60 m more than the shortest side. If the longer side is 30 m more than the shorter side, find the sides of the field.
9. The perimeter of a right triangle is 60 cm. Its hypotenuse is 25 cm. Find the area of the triangle.
10. The side of a square exceeds the side of the another square by 4 cm and the sum of the areas of the two squares is 400 cm^2 . Find the dimensions of the squares.

11. The length of the rectangle exceeds its breadth by 8 cm and the area of the rectangle is 240 cm^2 . Find the dimensions of the rectangle.
12. A chess board contains 64 squares and the area of each square is 6.25 cm^2 . A border round the board is 2 cm wide. Find the length of the side of the chess board.
13. A rectangular field is 25 m long and 16 m broad. There is a path of equal width all around inside it. If the area of the path is 148 m^2 , find the width of the path.
14. The length of a rectangle is thrice as long as the side of a square. The side of the square is 4 cm more than the breadth of the rectangle. Their areas being equal, find their dimensions.
15. A farmer prepares a rectangular vegetable garden of area 180 m^2 . With 39 m of barbed wire, he can fence the three sides of the garden, leaving one of the longer sides unfenced. Find the dimensions of the garden.
16. A rectangular field is 16 m long and 10 m broad. There is a path of equal width all around inside it. If the area of the path is 120 m^2 , find the width of the path.
17. The area of right triangle is 600 cm^2 . If the base of the triangle exceeds the altitude by 10 cm, find the dimensions of the triangle.
18. The area of right triangle is 96 m^2 . If the base of the triangle three times the altitude, find the dimensions of the triangle.
19. The length of the hypotenuse of a right triangle exceeds the length of the base by 2 cm and exceeds twice the length of the altitude by 1 cm. Find the length of each side of the triangle.
20. The hypotenuse of a right triangle is 1 m less than twice the shortest side. If the third side is 1 m more than the shortest side, find the sides of the triangle.

XI. TIME AND WORK RELATED QUESTIONS

1. Two water taps together can fill a tank in $9\frac{3}{8}$ hours. The tap of larger diameter takes 10 hours less than the smaller one to fill the tank separately. Find the time in which each tap can separately fill the tank.
2. A takes 6 days less than the time taken by B to finish a piece of work. If both A and B together can finish it in 4 days, find the time taken by B to finish the work.
3. Two pipes running together can fill a cistern in $3\frac{1}{13}$ hours. If one pipe takes 3 minutes more than the other to fill the cistern. Find the time in which each pipe can separately fill the cistern.
4. A takes 10 days less than the time taken by B to finish a piece of work. If both A and B together can finish it in 12 days, find the time taken by B to finish the work.
5. If two pipes function simultaneously, a reservoir will be filled in 12 hours. One pipe fills the reservoir 10 hours faster than the other. How many hours will the second pipe take to fill the reservoir?

XII. REASONING BASED QUESTIONS

1. In a class test, the sum of Ranjitha's marks in mathematics and English is 40. Had she got 3 marks more in mathematics and 4 marks less in English, the product of the marks would have been 360. Find her marks in two subjects separately.
2. Out of a number of saras birds, one-fourth of the number are moving about in lots, $\frac{1}{9}$ th coupled with $\frac{1}{4}$ th as well as 7 times the square root of the number move on a hill, 56 birds remain in vakula trees. What is the total number of trees?

3. A teacher attempting to arrange the students for mass drill in the form of a solid square found that 24 students were left. When he increased the size of the square by 1 student, he found that he was short of 25 students. Find the number of students.
4. A rectangular park is to be designed whose breadth is 3 m less than its length. Its area is to be 4 square metres more than the area of a park that has already been made in the shape of an isosceles triangle with its base as the breadth of the rectangular park and of altitude 12 m (see Fig. 4.3). Find its length and breadth.
5. John and Jivanti together have 45 marbles. Both of them lost 5 marbles each, and the product of the number of marble they now have is 124. We would like to find out how many marbles they had to start with.
6. In a class test, the sum of Shefali's marks in Mathematics and English is 30. Had she got 2 marks more in Mathematics and 3 marks less in English, the product of their marks would have been 210. Find her marks in the two subjects.
7. 300 apples are distributed equally among a certain number of students. Had there been 10 more students, each would have received one apple less. Find the number of students.
8. A man buys a number of pens for Rs. 80. If he has bought 4 more pens for the same amount, each pen would have cost him Re. 1 less. How many pens did he buy?
9. One-fourth of a herd of camels was seen in the forest. Twice the square root of the herd had gone to mountains and the remaining 15 camels were seen on the bank of a river. Find the total number of camels.
10. Out of a group of swans, $\frac{7}{2}$ times the square root of the number are playing on the shore of a tank. The two remaining ones are playing with amorous fight in the water. What is the total number of swans?
11. In a class test, the sum of the marks obtained by P in mathematics and science is 28. Had he got 3 more marks in mathematics and 4 marks less in science, the product of marks obtained in the two subjects would have been 180. Find the marks obtained by him in the two subjects separately.
12. Rs 250 was divided equally among a certain number of children. If there were 25 more children, each would have received 50 paise less. Find the number of children.
13. A peacock is sitting on the top of a pillar, which is 9m high. From a point 27 m away from the bottom of the pillar, a snake is coming to its hole at the base of the pillar. Seeing the snake the peacock pounces on it. If their speeds are equal at what distance from the whole is the snake caught?
14. A shopkeeper buys a number of books for Rs. 80. If he had bought 4 more books for the same amount, each book would have cost Rs. 1 less. How many books did he buy?
15. If the list price of a toy is reduced by Rs. 2, a person can buy 2 toys more for Rs. 360. Find the original price of the toy.



CLASS X : CHAPTER - 5
ARITHMETIC PROGRESSION (AP)

IMPORTANT FORMULAS & CONCEPTS

SEQUENCE

An arrangement of numbers in a definite order according to some rule is called a sequence. In other words, a pattern of numbers in which succeeding terms are obtained from the preceding term by adding/subtracting a fixed number or by multiplying with/dividing by a fixed number, is called sequence or list of numbers.

e.g. 1,2,3,4,5

A sequence is said to be finite or infinite accordingly it has finite or infinite number of terms. The various numbers occurring in a sequence are called its terms.

ARITHMETIC PROGRESSION (AP).

An **arithmetic progression** is a list of numbers in which each term is obtained by adding a fixed number to the preceding term except the first term.

This fixed number is called the common difference of the AP. It can be positive, negative or zero.

Let us denote the first term of an AP by a_1 , second term by a_2 , . . . , n th term by a_n and the common difference by d . Then the AP becomes $a_1, a_2, a_3, \dots, a_n$.

So, $a_2 - a_1 = a_3 - a_2 = \dots = a_n - a_{n-1} = d$.

The general form of an arithmetic progression is given by

$$a, a + d, a + 2d, a + 3d, \dots$$

where a is the first term and d the common difference.

n th Term of an AP

Let a_1, a_2, a_3, \dots be an AP whose first term a_1 is a and the common difference is d .

Then,

the **second term** $a_2 = a + d = a + (2 - 1) d$

the **third term** $a_3 = a_2 + d = (a + d) + d = a + 2d = a + (3 - 1) d$

the **fourth term** $a_4 = a_3 + d = (a + 2d) + d = a + 3d = a + (4 - 1) d$

.....
.....

Looking at the pattern, we can say that the **n th term** $a_n = a + (n - 1) d$.

So, **the n th term a_n of the AP with first term a and common difference d is given by**

$$a_n = a + (n - 1) d.$$

a_n is also called the **general term of the AP**. If there are m terms in the AP, then a_m represents the **last term which is sometimes also denoted by l** .

n th Term from the end of an AP

Let the last term of an AP be ' l ' and the common difference of an AP is ' d ' then the n th term from the end of an AP is given by

$$l_n = l - (n - 1) d.$$

Sum of First n Terms of an AP

The sum of the first n terms of an AP is given by

$$S_n = \frac{n}{2}[2a + (n-1)d]$$

where a = first term, d = common difference and n = number of terms.

Also, it can be written as

$$S_n = \frac{n}{2}[a + a_n]$$

where a_n = n th terms

or

$$S_n = \frac{n}{2}[a + l]$$

where l = last term

This form of the result is useful when the first and the last terms of an AP are given and the common difference is not given..

$$\text{Sum of first } n \text{ positive integers is given by } S_n = \frac{n(n+1)}{2}$$

Problems based on finding a_n if S_n is given.

Find the n th term of the AP, follow the steps:

- Consider the given sum of first n terms as S_n .
- Find the value of S_1 and S_2 by substituting the value of n as 1 and 2.
- The value of S_1 is a_1 i.e. a = first term and $S_2 - S_1 = a_2$
- Find the value of $a_2 - a_1 = d$, common difference.
- By using the value of a and d , Write AP.

Problems based on finding S_n if a_n is given.

Find the sum of n term of an AP, follow the steps:

- Consider the n th term of an AP as a_n .
- Find the value of a_1 and a_2 by substituting the value of n as 1 and 2.
- The value of a_1 is a = first term.
- Find the value of $a_2 - a_1 = d$, common difference.
- By using the value of a and d , Write AP.
- By using S_n formula, simplify the expression after substituting the value of a and d .

Arithmetic Mean

If a , b and c are in AP, then ' b ' is known as arithmetic mean between ' a ' and ' c '

$$b = \frac{a+c}{2} \text{ i.e. AM between 'a' and 'c' is } \frac{a+c}{2}.$$

MCQ WORKSHEET-I
CLASS X: CHAPTER – 5
ARITHMETIC PROGRESSION

1. If $p - 1$, $p + 3$, $3p - 1$ are in AP, then p is equal to
(a) 4 (b) -4 (c) 2 (d) -2
2. The sum of all terms of the arithmetic progression having ten terms except for the first term is 99 and except for the sixth term 89. Find the third term of the progression if the sum of the first term and the fifth term is equal to 10
(a) 15 (b) 5 (c) 8 (d) 10
3. If in any decreasing arithmetic progression, sum of all its terms, except the first term is equal to -36 , the sum of all its terms, except for the last term is zero and the difference of the tenth and the sixth term is equal to -16 , then first term of the series is
(a) 15 (b) 14 (c) 16 (d) 17
4. If the third term of an AP is 12 and the seventh term is 24, then the 10th term is
(a) 33 (b) 34 (c) 35 (d) 36
5. The first term of an arithmetic progression is unity and the common difference is 4. Which of the following will be a term of this AP ?
(a) 4551 (b) 10091 (c) 7881 (d) 13531
6. A number 15 is divided into three parts which are in AP and sum of their squares is 83. The smallest part is
(a) 2 (b) 5 (c) 3 (d) 6
7. How many terms of an AP must be taken for their sum to be equal to 120 if its third term is 9 and the difference between the seventh and second term is 20 ?
(a) 7 (b) 8 (c) 9 (d) 6
8. 9th term of an AP is 499 and 499th term is 9. The term which is equal to zero is
(a) 507th (b) 508th (c) 509th (d) 510th
9. The sum of all two digit numbers which when divided by 4 yield unity as remainder is
(a) 1012 (b) 1201 (c) 1212 (d) 1210
10. An AP consist of 31 terms if its 16th term is m , then sum of all the terms of this AP is
(a) $16m$ (b) $47m$ (c) $31m$ (d) $52m$
11. If a clock strikes once at one O'clock, twice at two O'clock, thrice at 3 O'clock and so on and again once at one O'clock and so on, then how many times will the bell be struck in the course of 2 days ?
(a) 156 (b) 312 (c) 78 (d) 288
12. In a certain AP, 5 times the 5th term is equal to 8 times the 8th term, then its 13th term is equal to
(a) 5 (b) 1 (c) 0 (d) 13

MCQ WORKSHEET-II
CLASS X: CHAPTER – 5
ARITHMETIC PROGRESSION

1. The sum of 5 numbers in AP is 30 and sum of their squares is 220. Which of the following is the third term ?
(a) 5 (b) 6 (c) 7 (d) 8
2. If a, b, c, d, e and f are in AP, then $e - c$ is equal to
(a) $2(c - a)$ (b) $2(f - d)$ (c) $2(d - c)$ (d) $d - c$
3. The sum of n terms of the series 2, 5, 8, 11,..... is 60100, then n is
(a) 100 (b) 150 (c) 200 (d) 250
4. The value of the expression $1 - 6 + 2 - 7 + 3 - 8 + \dots$ to 100 terms
(a) -225 (b) -250 (c) -300 (d) -350
5. Four numbers are inserted between the numbers 4 and 39 such that an AP results. Find the biggest of these four numbers
(a) 30 (b) 31 (c) 32 (d) 33
6. The sum of the first ten terms of an AP is four times the sum of the first five terms, then the ratio of the first term to the common difference is
(a) $1/2$ (b) 2 (c) $1/4$ (d) 4
7. Two persons Anil and Happy joined D. W. Associates. Anil and Happy started with an initial salary of Rs. 50000 and Rs. 64000 respectively with annual increment of Rs.2500 and Rs. 2000 each respectively. In which year will Anil start earning more salary than Happy ?
(a) 28th (b) 29th (c) 30th (d) 27th
8. A man receives Rs. 60 for the first week and Rs. 3 more each week than the preceding week. How much does he earn by the 20th week ?
(a) Rs. 1760 (b) Rs. 1770 (c) Rs. 1780 (d) Rs. 1790
9. Find 10th term whose 5th term is 24 and difference between 7th term and 10th term is 15
(a) 34 (b) 39 (c) 44 (d) 49
10. Find the sum of first n terms of odd natural number.
(a) n^2 (b) $n^2 - 1$ (c) $n^2 + 1$ (d) $2n - 1$
11. Common difference of an A.P. is -2 and first term is 80. Find the sum if last term is 10.
(a) 1600 (b) 1620 (c) 1650 (d) 1700
12. Find the sum of first 30 terms of an A. P. whose n^{th} term is $2 + 1/2n$
(a) 292.5 (b) 290.5 (c) 192.5 (d) none of these
13. Find 15th term of -10, -5, 0, 5, -----
(a) 55 (b) 60 (c) 65 (d) none of these
14. If the numbers a, b, c, d, e form an AP, then the value of $a - 4b + 6c - 4d + e$ is
(a) 1 (b) 2 (c) 0 (d) none of these

MCQ WORKSHEET-III
CLASS X: CHAPTER – 5
ARITHMETIC PROGRESSION

1. 7th term of an AP is 40. The sum of its first 13th terms is
(a) 500 (b) 510 (c) 520 (d) 530

2. The sum of the first four terms of an AP is 28 and sum of the first eight terms of the same AP is 88. Sum of first 16 terms of the AP is
(a) 346 (b) 340 (c) 304 (d) 268

3. Which term of the AP 4, 9, 14, 19, is 109?
(a) 14th (b) 18th (c) 22nd (d) 16th

4. How many terms are there in the arithmetic series $1 + 3 + 5 + \dots + 73 + 75$?
(a) 28 (b) 30 (c) 36 (d) 38

5. $51 + 52 + 53 + 54 + \dots + 100 = ?$
(a) 3775 (b) 4025 (c) 4275 (d) 5050

6. How many natural numbers between 1 and 1000 are divisible by 5?
(a) 197 (b) 198 (c) 199 (d) 200

7. If a, $a - 2$ and $3a$ are in AP, then the value of a is
(a) -3 (b) -2 (c) 3 (d) 2

8. How many terms are there in the AP 7, 10, 13, , 151?
(a) 50 (b) 55 (c) 45 (d) 49

9. The 4th term of an AP is 14 and its 12th term is 70. What is its first term?
(a) -10 (b) -7 (c) 7 (d) 10

10. The first term of an AP is 6 and the common difference is 5. What will be its 11th term?
(a) 56 (b) 41 (c) 46 (d) none of these

11. Which term of the AP 72, 63, 54, is 0?
(a) 8th (b) 9th (c) 11th (d) 12th

12. The 8th term of an AP is 17 and its 14th term is -29 . The common difference of the AP is
(a) -2 (b) 3 (c) 2 (d) 5

13. Which term of the AP 2, -1 , -4 , -7 , is -40 ?
(a) 8th (b) 15th (c) 11th (d) 23rd

14. Which term of the AP 20, 17, 14, is the first negative term?
(a) 8th (b) 6th (c) 9th (d) 7th

15. The first, second and last terms of an AP are respectively 4, 7 and 31. How many terms are there in the given AP?
(a) 10 (b) 12 (c) 8 (d) 13

MCQ WORKSHEET-IV
CLASS X: CHAPTER – 5
ARITHMETIC PROGRESSION

1. The common difference of the A. P. whose general term $a_n = 2n + 1$ is
(a) 1 (b) 2 (c) - 2 (d) - 1
2. The number of terms in the A.P. 2, 5, 8, , 59 is
(a) 12 (b) 19 (c) 20 (d) 25
3. The first positive term of the A.P. -11, -8, -5,.... Is
(a) 1 (b) 3 (c) - 2 (d) - 4
4. The 4th term from the end of the A.P. 2, 5, 8,,35 is
(a) 29 (b) 26 (c) 23 (d) 20
5. The 11th and 13th terms of an A.P. are 35 and 41 respectively its common difference is
(a) 38 (b) 32 (c) 6 (d) 3
6. The next term of the A.P. $\sqrt{8}, \sqrt{18}, \sqrt{32}, \dots$ is
(a) $5\sqrt{2}$ (b) $5\sqrt{3}$ (c) $3\sqrt{3}$ (d) $4\sqrt{3}$
7. If for an A.P. $a_5 = a_{10} = 5a$, then a_{15} is
(a) 71 (b) 72 (c) 76 (d) 81
8. Which of the following is not an A.P.?
(a) 1, 4, 7, (b) 3, 7, 12, 18,
(c) 11, 14, 17, 20, (d) -5, -2, 1, 4,....
9. The sum of first 20 odd natural numbers is
(a) 281 (b) 285 (c) 400 (d) 421
10. The sum of first 20 natural numbers is
(a) 110 (b) 170 (c) 190 (d) 210
11. The sum of first 10 multiples of 7 is
(a) 315 (b) 371 (c) 385 (d) 406
12. If the sum of the A.P. 3, 7, 11, Is 210, the number of terms is
(a) 10 (b) 12 (c) 15 (d) 22
13. Write the next term of the AP $\sqrt{8}, \sqrt{18}, \sqrt{32}, \dots$
(a) $\sqrt{50}$ (b) $\sqrt{64}$ (c) $\sqrt{36}$ (d) $\sqrt{72}$
14. Which term of the AP 21, 18, 15, is zero?
(a) 8th (b) 6th (c) 9th (d) 7th
15. The sum of first 100 multiples of 5 is
(a) 50500 (b) 25250 (c) 500 (d) none of these

16. The sum of first 100 multiples of 9 is
(a) 90900 (b) 25250 (c) 45450 (d) none of these
17. The sum of first 100 multiples of 6 is
(a) 60600 (b) 30300 (c) 15150 (d) none of these
18. The sum of first 100 multiples of 4 is
(a) 40400 (b) 20200 (c) 10100 (d) none of these
19. The sum of first 100 multiples of 3 is
(a) 30300 (b) 15150 (c) 300 (d) none of these
20. The sum of first 100 multiples of 8 is
(a) 20200 (b) 80800 (c) 40400 (d) none of these
-

PRACTICE QUESTIONS
CLASS X : CHAPTER – 5
ARITHMETIC PROGRESSIONS
“nth term of A.P.”

- Q1.** Determine the AP whose 3rd term is 5 and the 7th term is 9.
- Q2.** The 8th term of an AP is 37 and its 12th term is 57. Find the AP.
- Q3.** The 7th term of an AP is – 4 and its 13th term is – 16. Find the AP.
- Q4.** If the 10th term of an AP is 52 and the 17th term is 20 more than the 13th term, find the AP.
- Q5.** If the 8th term of an AP is 31 and its 15th term is 16 more than the 11th term, find the AP.
- Q6.** Check whether 51 is a term of the AP 5, 8, 11, 14,?
- Q7.** The 6th term of an AP is – 10 and its 10th term is – 26. Determine the 15th term of the AP.
- Q8.** The sum of 4th term and 8th term of an AP is 24 and the sum of 6th and 10th terms is 44. Find the AP.
- Q9.** The sum of 5th term and 9th term of an AP is 72 and the sum of 7th and 12th terms is 97. Find the AP.
- Q10.** Find the 105th term of the A.P. 4, $4\frac{1}{2}$, 5, $5\frac{1}{2}$, 6,.....
- Q11.** Find 25th term of the AP $5, 4\frac{1}{2}, 4, 3\frac{1}{2}, 3, \dots$
- Q12.** Find the 37th term of the AP $6, 7\frac{3}{4}, 9\frac{1}{2}, 11\frac{3}{4}, \dots$
- Q13.** Find 9th term of the AP $\frac{3}{4}, \frac{5}{4}, \frac{7}{4}, \frac{9}{4}, \dots$
- Q14.** An AP consists of 50 terms of which 3rd term is 12 and the last term is 106. Find the 29th term.
- Q15.** Determine the AP whose third term is 16 and the 7th term exceeds the 5th term by 12.
- Q16.** The 17th term of an AP exceeds its 10th term by 7. Find the common difference.
- Q17.** If the nth term of an AP is $(5n - 2)$, find its first term and common difference. Also find its 19th term.
- Q18.** If the nth term of an AP is $(4n - 10)$, find its first term and common difference. Also find its 16th term.
- Q19.** If $2x, x + 10, 3x + 2$ are in A.P., find the value of x.

- Q20.** If $x + 1$, $3x$ and $4x + 2$ are in AP, find the value of x .
- Q21.** Find the value of x for which $(8x + 4)$, $(6x - 2)$ and $(2x + 7)$ are in AP.
- Q22.** Find the value of x for which $(5x + 2)$, $(4x - 1)$ and $(x + 2)$ are in AP.
- Q23.** Find the value of m so that $m + 2$, $4m - 6$ and $3m - 2$ are three consecutive terms of an AP.
- Q24.** Find the 20th term from the last term of the AP : 3, 8, 13, . . . , 253.
- Q25.** Find the 11th term from the last term (towards the first term) of the AP : 10, 7, 4, . . . , - 62.
- Q26.** Find the 10th term from the last term of the AP : 4, 9, 14, . . . , 254.
- Q27.** Find the 6th term from the end of the AP 17, 14, 11, (-40).
- Q28.** Find the 8th term from the end of the AP 7, 10, 13, 184.
- Q29.** Find the 10th term from the last term of the AP : 8, 10, 12, . . . , 126.
- Q30.** Find the 31st term of an AP whose 11th term is 38 and the 16th term is 73.
- Q31.** If the 3rd and the 9th terms of an AP are 4 and -8 respectively, which term of this AP is zero?
- Q32.** Two APs have the same common difference. The difference between their 100th terms is 100, what is the difference between their 1000th terms?
- Q33.** For what value of n , are the n th terms of two APs: 63, 65, 67, . . . and 3, 10, 17, . . . equal?
- Q34.** For what value of n , are the n th terms of two APs: 13, 19, 25, . . . and 69, 68, 67, . . . equal?
- Q35.** The 8th term of an AP is zero. Prove that its 38th term is triple its 18th term.
- Q36.** The 4th term of an AP is 0. Prove that its 25th term is triple its 11th term.
- Q37.** If the m th term of an AP be $\frac{1}{n}$ and its n th term be $\frac{1}{m}$, then show that its (mn) th term is 1.
- Q38.** If m times the m th term of an AP is equal to n times the n th term and $m \neq n$, show that its $(m + n)$ th term is 0.
- Q39.** If the p th term of an AP is q and q th term of an AP is p , prove that its n th is $(p + q - n)$.
- Q40.** If the p th, q th and r th terms of an AP is a , b , c respectively, then show that $a(q - r) + b(r - p) + c(p - q) = 0$.
- Q41.** If the p th, q th and r th terms of an AP is a , b , c respectively, then show that $p(b - c) + q(c - a) + r(a - b) = 0$.
- Q42.** If the n th term of a progression be a linear expression in n , then prove that this progression is an AP.
- Q43.** The sum of three numbers in AP is 21 and their product is 231. Find the numbers.

- Q44.** The sum of three numbers in AP is 27 and their product is 405. Find the numbers.
- Q45.** The sum of three numbers in AP is 15 and their product is 80. Find the numbers.
- Q46.** Find three numbers in AP whose sum is 3 and product is -35 .
- Q47.** Divide 24 in three parts such that they are in AP and their product is 440.
- Q48.** The sum of three consecutive terms of an AP is 21 and the sum of the squares of these terms is 165. Find the terms.
- Q49.** Find four numbers in AP whose sum is 20 and the sum of whose squares is 120.
- Q50.** Find four numbers in AP whose sum is 28 and the sum of whose squares is 216.
- Q51.** Find four numbers in AP whose sum is 50 and in which the greatest number is 4 times the least.
- Q52.** The angles of a quadrilateral are in AP whose common difference is 10° . Find the angles.
- Q53.** Show that $(a - b)^2$, $(a^2 + b^2)$ and $(a + b)^2$ are in AP.
- Q54.** If 10^{th} times the 10^{th} term of an AP is equal to 15 times the 15^{th} term, show that its 25^{th} term is 0.
- Q55.** If 5 times the 5^{th} term of an AP is equal to 8 times its 8^{th} term, show that the 13^{th} term is 0.
- Q56.** How many terms are there in the AP 7, 11, 15, , 139?
- Q57.** How many terms are there in A.P. 7,11,15,.....139?
- Q58.** How many terms are there in the AP 6, 10, 14, 18, 174.
- Q59.** How many three-digit numbers are divisible by 7?
- Q60.** How many multiples of 7 between 50 and 500?
- Q61.** How many multiples of 4 lie between 10 and 250?
- Q62.** How many terms are there in the AP 41, 38, 35, , 8.
- Q63.** Which term of the AP : 3, 8, 13, 18, . . . ,is 78?
- Q64.** Which term of the A.P. 5, 13, 21, is 181?
- Q65.** Which term of the A.P. 5, 9, 13, 17,..... is 81?
- Q66.** Which term of the AP 3, 8, 13, 18,..... will be 55 more than its 20^{th} term?
- Q67.** Which term of the AP 8, 14, 20, 26,.... will be 72 more than its 41^{st} term?
- Q68.** Which term of the AP 9, 12, 15, 18,.... will be 39 more than its 36^{th} term?

- Q69.** Which term of the AP 3, 15, 27, 39,.... will be 120 more than its 21st term?
- Q70.** Which term of the AP 24, 21, 18, 15, Is first negative term?
- Q71.** Which term of the AP 3, 8, 13, 18, is 88?
- Q72.** Which term of the AP 72, 68, 64, 60, is 0?
- Q73.** Which term of the AP : 3, 15, 27, 39, . . . will be 132 more than its 54th term?
- Q74.** Which term of the AP $\frac{5}{6}, 1, 1\frac{1}{6}, 1\frac{1}{3}, \dots$ is 3 ?
- Q75.** A sum of Rs. 1000 is invested at 8% simple interest per year. Calculate the interest at the end of each year. Does this interest form an AP? If so, find the interest at the end of 30 years.
- Q76.** In a flower bed, there are 23 rose plants in the first row, 21 in the second, 19 in the third, and so on. There are 5 rose plants in the last row. How many rows are there in the flower bed?
- Q77.** The sum of the 4th and 8th terms of an AP is 24 and the sum of the 6th and 10th terms is 44. Find the first three terms of the AP.
- Q78.** Manish saved Rs. 50 in the first week of the year and then increased his weekly savings by Rs. 17.50 each week. In what week will his weekly savings be Rs. 207.50?
- Q79.** Subba Rao started work in 1995 at an annual salary of Rs 5000 and received an increment of Rs 200 each year. In which year did his income reach Rs 7000?
- Q80.** Ramkali saved Rs 5 in the first week of a year and then increased her weekly savings by Rs 1.75. If in the n th week, her weekly savings become Rs 20.75, find n .
-

PRACTICE QUESTIONS
CLASS X : CHAPTER – 5
ARITHMETIC PROGRESSIONS
“SUM OF n TERMS OF AN A.P.”

1. Find the sum of first 24 terms of the AP 5, 8, 11, 14,.....
2. Find the sum: $25 + 28 + 31 + \dots + 100$.
3. Find the sum of first 21 terms of the AP whose 2nd term is 8 and 4th term is 14.
4. If the nth term of an AP is $(2n + 1)$, find the sum of first n terms of the AP.
5. Find the sum of first 25 terms of an AP whose nth term is given by $(7 - 3n)$.
6. Find the sum of all two-digit odd positive numbers.
7. Find the sum of all natural number between 100 and 500 which are divisible by 8.
8. Find the sum of all three digit natural numbers which are multiples of 7.
9. How many terms of the AP 3, 5, 7, 9,... must be added to get the sum 120?
10. If the sum of first n, 2n and 3n terms of an AP be S_1 , S_2 and S_3 respectively, then prove that $S_3 = 3(S_2 - S_1)$.
11. If the sum of the first m terms of an AP be n and the sum of first n terms be m then show that the sum of its first $(m + n)$ terms is $-(m + n)$.
12. If the sum of the first p terms of an AP is the same as the sum of first q terms (where $p \neq q$) then show that the sum of its first $(p + q)$ terms is 0.
13. If the pth term of an AP is $\frac{1}{q}$ and its qth term is $\frac{1}{p}$, show that the sum of its first pq terms is $\frac{1}{2}(p + q)$.
14. Find the sum of all natural numbers less than 100 which are divisible by 6.
15. Find the sum of all natural number between 100 and 500 which are divisible by 7.
16. Find the sum of all multiples of 9 lying between 300 and 700.
17. Find the sum of all three digit natural numbers which are divisible by 13.
18. Find the sum of 51 terms of the AP whose second term is 2 and the 4th term is 8.
19. The sum of n terms of an AP is $(5n^2 - 3n)$. Find the AP and hence find its 10th term.

20. The first and last terms of an AP are 4 and 81 respectively. If the common difference is 7, how many terms are there in the AP and what is their sum?
21. If the sum of first 7 terms of AP is 49 and that of first 17 terms is 289, find the sum of first n terms.
22. Find the sum of the first 100 even natural numbers which are divisible by 5.
23. Find the sum of the following: $\left(1 - \frac{1}{n}\right) + \left(1 - \frac{2}{n}\right) + \left(1 - \frac{3}{n}\right) \dots \dots \dots$ upto n terms.
24. If the 5th and 12th terms of an AP are - 4 and - 18 respectively, find the sum of first 20 terms of the AP.
25. The sum of n terms of an AP is $\left(\frac{5n^2}{2} + \frac{3n}{2}\right)$. Find its 20th term
26. The sum of n terms of an AP is $\left(\frac{3n^2}{2} + \frac{5n}{2}\right)$. Find its 25th term
27. Find the number of terms of the AP 18, 15, 12, so that their sum is 45. Explain the double answer.
28. Find the number of terms of the AP 64, 60, 56, so that their sum is 544. Explain the double answer.
29. Find the number of terms of the AP 17, 15, 13, so that their sum is 72. Explain the double answer.
30. Find the number of terms of the AP 63, 60, 57, so that their sum is 693. Explain the double answer.
31. The sum of first 9 terms of an AP is 81 and the sum of its first 20 terms is 400. Find the first term and the common difference of the AP.
32. If the nth term of an AP is $(4n + 1)$, find the sum of the first 15 terms of this AP. Also find the sum of is n terms.
33. The sum of the first n terms of an AP is given by $S_n = (2n^2 + 5n)$. Find the nth term of the AP.
34. If the sum of the first n terms of an AP is given by $S_n = (3n^2 - n)$, find its 20th term.
35. If the sum of the first n terms of an AP is given by $S_n = (3n^2 + 2n)$, find its 25th term.
36. How many terms of the AP 21, 18, 15,.... Must be added to get the sum 0?
37. Find the sum of first 24 terms whose nth term is given by $a_n = 3 + 2n$.
38. How many terms of the AP $-6, \frac{-11}{2}, -5, \dots \dots \dots$ are needed to give the sum -25? Explain the double answer.

39. Find the sum of first 24 terms of the list of numbers whose n th term is given by $a_n = 3 + 2n$
40. How many terms of the AP : 24, 21, 18, . . . must be taken so that their sum is 78?
41. Find the sum of the first 40 positive integers divisible by 6.
42. Find the sum of all the two digit numbers which are divisible by 4.
43. Find the sum of all two digits natural numbers greater than 50 which, when divided by 7 leave remainder of 4.
44. If the sum of first 7 terms of an AP is 49 and that of 17 terms is 289 , find the sum of first n terms
45. If the sum of first n terms of an A.P. is given by $S_n = 3n^2 + 5n$, find the n th term of the A.P.
46. The sum of first 8 terms of an AP is 100 and the sum of its first 19 terms is 551. Find the AP.
47. How many terms are there in A.P. whose first terms and 6^{th} term are -12 and 8 respectively and sum of all its terms is 120 ?
48. 200 logs are stacked in the following manner: 20 logs in the bottom row, 19 in the next row, 18 in the row next to it and so on. In how many rows are the 200 logs placed and how many logs are in the top row?
49. A man repays a loan of Rs. 3250 by paying Rs. 20 in the first month and then increase the payment by Rs. 15 every month. How long will it take him to clear the loan?
50. Raghav buys a shop for Rs. 1,20,000. He pays half of the amount in cash and agrees to pay the balance in 12 annual installments of Rs. 5000 each. If the rate of interest is 12% and he pays with the installment the interest due on the unpaid amount, find the total cost of the shop.
51. A sum of Rs. 280 is to be used to give four cash prizes to students of a school for their overall academic performance. If each prize is Rs. 20 less than its preceding prize, find the value of each of the prizes.
52. A sum of Rs 700 is to be used to give seven cash prizes to students of a school for their overall academic performance. If each prize is Rs 20 less than its preceding prize, find the value of each of the prizes.
53. A contract on construction job specifies a penalty for delay of completion beyond a certain date as follows: Rs 200 for the first day, Rs 250 for the second day, Rs 300 for the third day, etc., the penalty for each succeeding day being Rs 50 more than for the preceding day. How much money the contractor has to pay as penalty, if he has delayed the work by 30 days?
54. A manufacturer of TV sets produced 600 sets in the third year and 700 sets in the seventh year. Assuming that the production increases uniformly by a fixed number every year, find : (i) the production in the 1st year (ii) the production in the 10th year (iii) the total production in first 7 years
55. How many terms of the AP : 9, 17, 25, . . . must be taken to give a sum of 636?
56. The first term of an AP is 5, the last term is 45 and the sum is 400. Find the number of terms and the common difference.

57. The first and the last terms of an AP are 17 and 350 respectively. If the common difference is 9, how many terms are there and what is their sum?
58. Find the sum of first 22 terms of an AP in which $d = 7$ and 22nd term is 149.
59. Find the sum of first 51 terms of an AP whose second and third terms are 14 and 18 respectively.
60. If the sum of first 7 terms of an AP is 49 and that of 17 terms is 289, find the sum of first n terms.
61. Show that $a_1, a_2, \dots, a_n, \dots$ form an AP where a_n is defined as below : (i) $a_n = 3 + 4n$
(ii) $a_n = 9 - 5n$ Also find the sum of the first 15 terms in each case.
62. If the sum of the first n terms of an AP is $4n - n^2$, what is the first term (that is S_1)? What is the sum of first two terms? What is the second term? Similarly, find the 3rd, the 10th and the n th terms.
63. Find the sum of the first 15 multiples of 8.
64. Find the sum of the odd numbers between 0 and 50.
65. In a school, students thought of planting trees in and around the school to reduce air pollution. It was decided that the number of trees, that each section of each class will plant, will be the same as the class, in which they are studying, e.g., a section of Class I will plant 1 tree, a section of Class II will plant 2 trees and so on till Class XII. There are three sections of each class. How many trees will be planted by the students?
66. A spiral is made up of successive semicircles, with centres alternately at A and B, starting with centre at A, of radii 0.5 cm, 1.0 cm, 1.5 cm, 2.0 cm, What is the total length of such a spiral made up of thirteen consecutive semicircles? (Take $\pi = 22/7$)

CLASS X : CHAPTER - 6 TRIANGLES

IMPORTANT FORMULAS & CONCEPTS

All those objects which have the same shape but different sizes are called similar objects.

Two triangles are similar if

- (i) their corresponding angles are equal (or)
- (ii) their corresponding sides have lengths in the same ratio (or proportional)

Two triangles $\triangle ABC$ and $\triangle DEF$ are similar if

(i) $\angle A = \angle D, \angle B = \angle E, \angle C = \angle F$

(ii) $\frac{AB}{DE} = \frac{BC}{EF} = \frac{CA}{FD}$

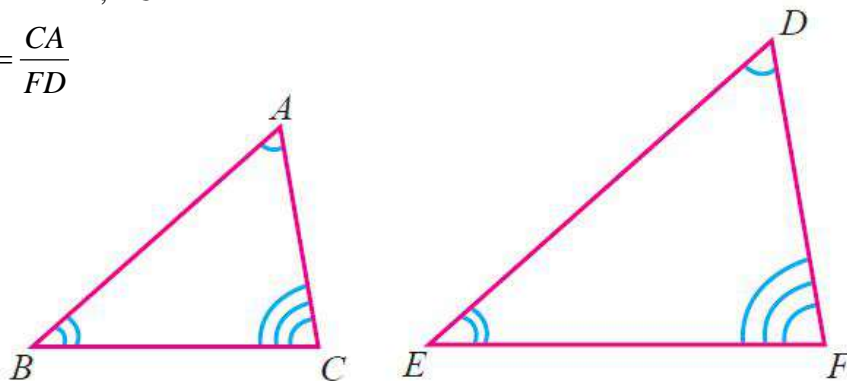

Basic Proportionality theorem or Thales Theorem

If a straight line is drawn parallel to one side of a triangle intersecting the other two sides, then it divides the two sides in the same ratio.

If in a $\triangle ABC$, a straight line DE parallel to BC , intersects AB at D and AC at E , then

(i) $\frac{AB}{AD} = \frac{AC}{AE}$ (ii) $\frac{AB}{DB} = \frac{AC}{EC}$

Converse of Basic Proportionality Theorem (Converse of Thales Theorem)

If a straight line divides any two sides of a triangle in the same ratio, then the line must be parallel to the third side.

Angle Bisector Theorem

The internal (external) bisector of an angle of a triangle divides the opposite side internally (externally) in the ratio of the corresponding sides containing the angle.

Converse of Angle Bisector Theorem

If a straight line through one vertex of a triangle divides the opposite side internally (externally) in the ratio of the other two sides, then the line bisects the angle internally (externally) at the vertex.

Criteria for similarity of triangles

The following three criteria are sufficient to prove that two triangles are similar.

(i) AAA(Angle-Angle-Angle) similarity criterion

If in two triangles, corresponding angles are equal, then their corresponding sides are in the same ratio (or proportion) and hence the two triangles are similar.

Remark: If two angles of one triangle are respectively equal to two angles of another triangle, then the two triangles are similar.

(ii) SSS (Side-Side-Side) similarity criterion for Two Triangles

In two triangles, if the sides of one triangle are proportional (in the same ratio) to the sides of the other triangle, then their corresponding angles are equal and hence the two triangles are similar.

(iii) SAS (Side-Angle-Side) similarity criterion for Two Triangles

If one angle of a triangle is equal to one angle of the other triangle and if the corresponding sides including these angles are proportional, then the two triangles are similar.

Areas of Similar Triangles

The ratio of the areas of two similar triangles is equal to the ratio of the squares of their corresponding sides.

If a perpendicular is drawn from the vertex of a right angled triangle to its hypotenuse, then the triangles on each side of the perpendicular are similar to the whole triangle.

Here, (a) $\triangle DBA + \triangle ABC$

(b) $\triangle DAC + \triangle ABC$

(c) $\triangle DBA + \triangle DAC$

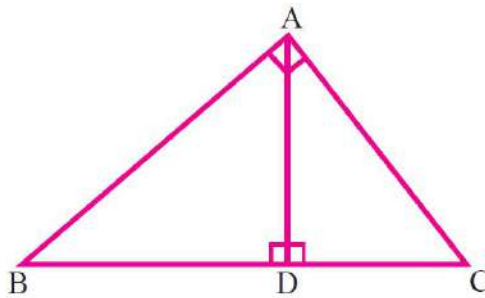

If two triangles are similar, then the ratio of the corresponding sides is equal to the ratio of their corresponding altitudes.

i.e., if $\triangle ABC + \triangle EFG$, then $\frac{AB}{DE} = \frac{BC}{FG} = \frac{CA}{GE} = \frac{AD}{EH}$

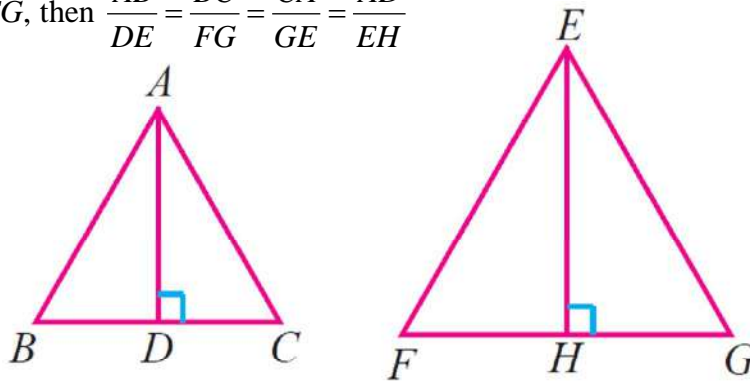

If two triangles are similar, then the ratio of the corresponding sides is equal to the ratio of the corresponding perimeters.

If $\triangle ABC + \triangle EFG$, then $\frac{AB}{DE} = \frac{BC}{FG} = \frac{CA}{GE} = \frac{AB + BC + CA}{DE + FG + GE}$

Pythagoras theorem (Baudhayan theorem)

In a right angled triangle, the square of the hypotenuse is equal to the sum of the squares of the other two sides.

Converse of Pythagoras theorem

In a triangle, if the square of one side is equal to the sum of the squares of the other two sides, then the angle opposite to the first side is a right angle.

MCQ WORKSHEET-I
CLASS X : CHAPTER - 6
TRIANGLES

1. If in triangle ABC and DEF, $\frac{AB}{DE} = \frac{BC}{FD}$, then they will be similar when
 (a) $\angle B = \angle E$ (b) $\angle A = \angle D$ (c) $\angle B = \angle D$ (d) $\angle A = \angle F$

2. It is given that $\triangle ABC \sim \triangle PQR$ with $\frac{BC}{QR} = \frac{1}{3}$, then $\frac{ar(\triangle ABC)}{ar(\triangle PQR)}$ is equal to
 (a) 9 (b) 3 (c) $\frac{1}{3}$ (d) $\frac{1}{9}$

3. In $\triangle ABC$, $DE \parallel BC$ and $AD = 4\text{cm}$, $AB = 9\text{cm}$. $AC = 13.5\text{ cm}$ then the value of EC is
 (a) 6 cm (b) 7.5 cm (c) 9 cm (d) none of these

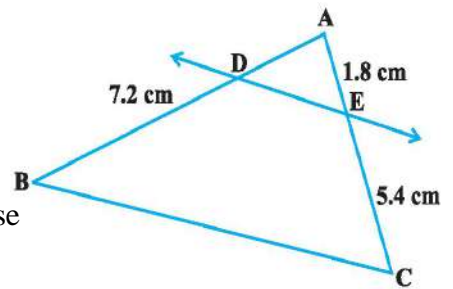

4. In figure $DE \parallel BC$ then the value of AD is
 (a) 2 cm (b) 2.4 cm (c) 3 cm (d) none of the above

5. ABC and BDE are two equilateral triangles such that $BD = \frac{2}{3} BC$. The ratio of the areas of triangles ABC and BDE are
 (a) 2 : 3 (b) 3 : 2 (c) 4 : 9 (d) 9 : 4

6. A ladder is placed against a wall such that its foot is at distance of 2.5 m from the wall and its top reaches a window 6 m above the ground. The length of the ladder is
 (a) 6.5 m (b) 7.5 m (c) 8.5 m (d) 9.5 m

7. If the corresponding sides of two similar triangles are in the ratio 4 : 9, then the areas of these triangles are in the ratio is
 (a) 2 : 3 (b) 3 : 2 (c) 81 : 16 (d) 16 : 81

8. If $\triangle ABC \sim \triangle PQR$, $BC = 8\text{ cm}$ and $QR = 6\text{ cm}$, the ratio of the areas of $\triangle ABC$ and $\triangle PQR$ is
 (a) 8 : 6 (b) 6 : 8 (c) 64 : 36 (d) 9 : 16

9. If $\triangle ABC \sim \triangle PQR$, area of $\triangle ABC = 81\text{cm}^2$, area of $\triangle PQR = 144\text{cm}^2$ and $QR = 6\text{ cm}$, then length of BC is
 (a) 4 cm (b) 4.5 cm (c) 9 cm (d) 12 cm

10. Sides of triangles are given below. Which of these is a right triangle?
 (a) 7 cm, 5 cm, 24 cm (b) 34 cm, 30 cm, 16 cm
 (c) 4 cm, 3 cm, 7 cm (d) 8 cm, 12 cm, 14 cm

11. If a ladder 10 m long reaches a window 8 m above the ground, then the distance of the foot of the ladder from the base of the wall is
 (a) 18 m (b) 8 m (c) 6 m (d) 4 m

12. A girl walks 200 towards East and the she walks 150m towards North. The distance of the girl from the starting point is
 (a) 350m (b) 250m (c) 300m (d) 225m

MCQ WORKSHEET-II
CLASS X : CHAPTER - 6
TRIANGLES

1. In the given figure, if $DE \parallel BC$, then x equals
 (a) 6 cm (b) 10 cm (c) 8 cm (d) 12.5 cm

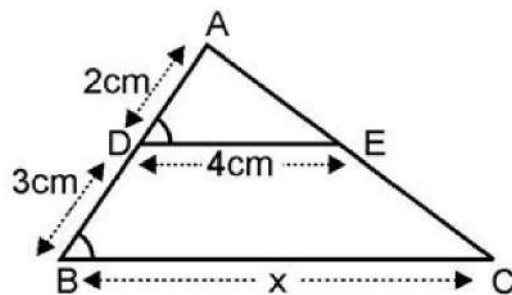

2. All _____ triangles are similar.
 (a) isosceles (b) equilateral (c) scalene
 (d) right angled
3. All circles are _____
 (a) congruent (b) similar (c) not similar
 (d) none of these

4. All squares are _____
 (a) congruent (b) similar (c) not similar (d) none of these

5. In the given fig $DE \parallel BC$ then the value of EC is
 (a) 1 cm (b) 2 cm (c) 3 cm (d) 4 cm

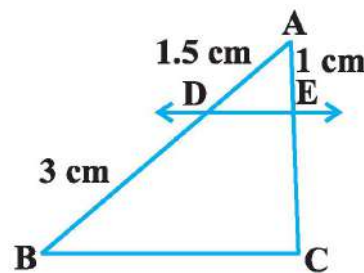

6. In the given below figure, the value of $\angle P$ is
 (a) 60° (b) 80° (c) 40° (d) 100°

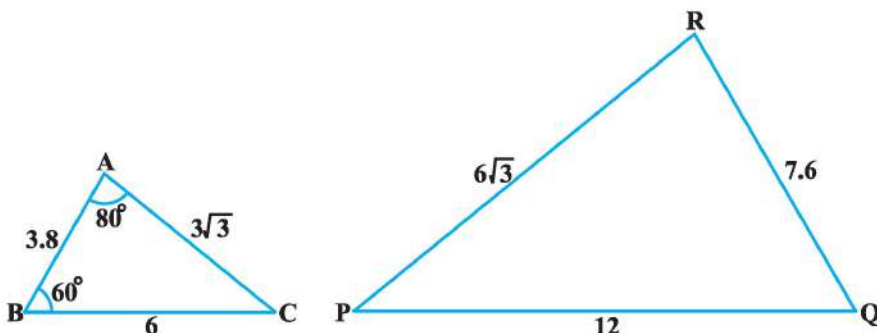

7. A girl of height 90 cm is walking away from the base of a lamp-post at a speed of 1.2 m/s. If the lamp is 3.6 m above the ground, then the length of her shadow after 4 seconds.

- (a) 1.2 m (b) 1.6 m (c) 2 m (d) none of these

8. A vertical pole of length 6 m casts a shadow 4 m long on the ground and at the same time a tower casts a shadow 28 m long. Find the height of the tower.

- (a) 42 m (b) 48 m (c) 54 m (d) none of these

9. $\triangle ABC \sim \triangle DEF$ and their areas be, respectively, 64 cm^2 and 121 cm^2 . If $EF = 15.4 \text{ cm}$, the value of BC is.

- (a) 11.2 cm (b) 15.4 cm (c) 6.4 cm (d) none of these

10. ABC and BDE are two equilateral triangles such that D is the midpoint of BC . Ratio of the areas of triangles ABC and BDE is

- (a) 2 : 1 (b) 1 : 2 (c) 4 : 1 (d) 1 : 4

11. Areas of two similar triangles are in the ratio 4 : 9. Sides of these triangles are in the ratio

- (a) 2 : 3 (b) 4 : 9 (c) 81 : 16 (d) 16 : 81

MCQ WORKSHEET-III
CLASS X : CHAPTER - 6
TRIANGLES

1. In the following fig. $XY \parallel QR$ and $\frac{PX}{XQ} = \frac{PY}{YR} = \frac{1}{2}$, then

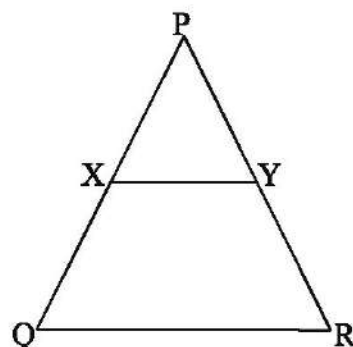

- (i) $XY = QR$
(ii) $XY = \frac{1}{3}QR$
(iii) $XY^2 = QR^2$
(iv) $XY = \frac{1}{2}QR$

2. In the following fig $QA \perp AB$ and $PB \perp AB$, then AQ is:

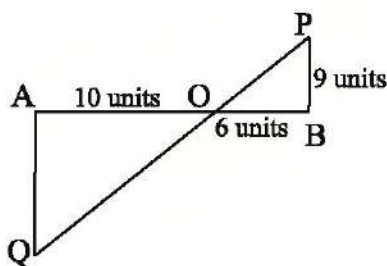

- (i) 15 units (ii) 8 units (iii) 5 units (iv) 9 units
3. The ratio of the areas of two similar triangles is equal to the:
- (i) ratio of their corresponding sides
(ii) ratio of their corresponding attitudes
(iii) ratio of the squares of their corresponding sides
(iv) ratio of the squares of their perimeter
4. The areas of two similar triangles are 144 cm^2 and 81 cm^2 . If one median of the first triangle is 16 cm, length of corresponding median of the second triangle is:
- (i) 9 cm (ii) 27 cm (iii) 12 cm (iv) 16 cm
5. In a right triangle ABC, in which $\angle C = 90^\circ$ and $CD \perp AB$. If $BC = a$, $CA = b$, $AB = c$ and $CD = p$.

- (i) $\frac{1}{p^2} = \frac{1}{a^2} + \frac{1}{b^2}$
(ii) $\frac{1}{p^2} \neq \frac{1}{a^2} + \frac{1}{b^2}$
(iii) $\frac{1}{p^2} < \frac{1}{a^2} + \frac{1}{b^2}$
(iv) $\frac{1}{p^2} > \frac{1}{a^2} + \frac{1}{b^2}$

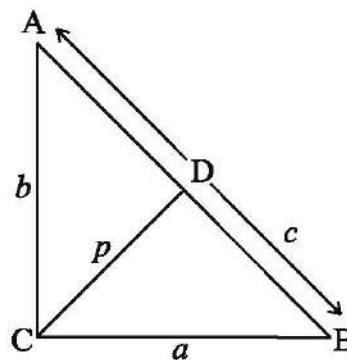

6. Given Quad. ABCD \sim Quad PQRS then x is:

- (i) 13 units
- (ii) 12 units
- (iii) 6 units
- (iv) 15 units

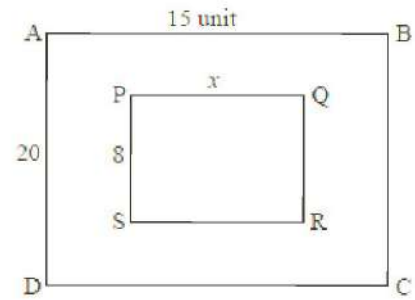

7. If $\Delta ABC \sim \Delta DEF$, $ar(\Delta DEF) = 100 \text{ cm}^2$ and $AB/DE = 1/2$ then $ar(\Delta ABC)$ is:

- (i) 50 cm^2
- (ii) 25 cm^2
- (iii) 4 cm^2
- (iv) None of the above.

8. If the three sides of a triangle are $a, \sqrt{3}a, \sqrt{2}a$, then the measure of the angle opposite to the longest side is:

- (i) 45°
- (ii) 30°
- (iii) 60°
- (iv) 90°

9. The similarity criterion used for the similarity of the given triangles shown in fig (iii) is

- (a) AAA
- (b) SSS
- (c) SAS
- (d) AA

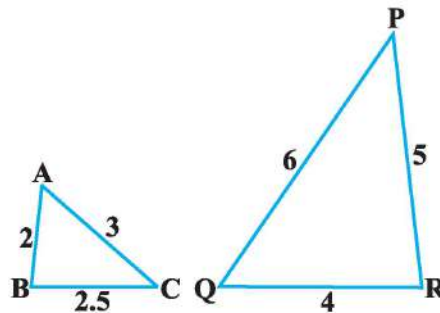

10. The similarity criterion used for the similarity of the given triangles shown in fig (iv) is

- (a) AAA
- (b) SSS
- (c) SAS
- (d) AA

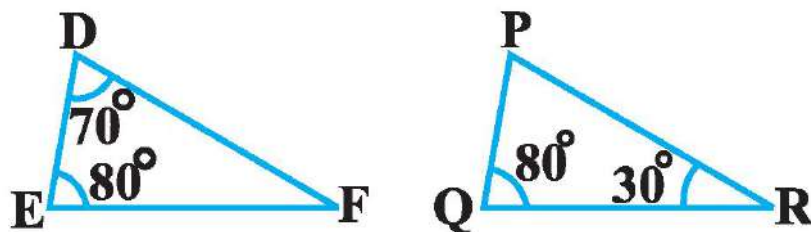

.....

MCQ WORKSHEET-IV
CLASS X : CHAPTER - 6
TRIANGLES

1. A vertical pole of length 20 m casts a shadow 10 m long on the ground and at the same time a tower casts a shadow 50 m long, then the height of the tower.
(a) 100 m (b) 120 m (c) 25 m (d) none of these
2. The areas of two similar triangles are in the ratio 4 : 9. The corresponding sides of these triangles are in the ratio
(a) 2 : 3 (b) 4 : 9 (c) 81 : 16 (d) 16 : 81
3. The areas of two similar triangles $\triangle ABC$ and $\triangle DEF$ are 144 cm^2 and 81 cm^2 , respectively. If the longest side of larger $\triangle ABC$ be 36 cm, then the longest side of the similar triangle $\triangle DEF$ is
(a) 20 cm (b) 26 cm (c) 27 cm (d) 30 cm
4. The areas of two similar triangles are in respectively 9 cm^2 and 16 cm^2 . The ratio of their corresponding sides is
(a) 2 : 3 (b) 3 : 4 (c) 4 : 3 (d) 4 : 5
5. Two isosceles triangles have equal angles and their areas are in the ratio 16 : 25. The ratio of their corresponding heights is
(a) 3 : 2 (b) 5 : 4 (c) 5 : 7 (d) 4 : 5
6. If $\triangle ABC$ and $\triangle DEF$ are similar such that $2AB = DE$ and $BC = 8 \text{ cm}$, then $EF =$
(a) 16 cm (b) 112 cm (c) 8 cm (d) 4 cm
7. XY is drawn parallel to the base BC of a $\triangle ABC$ cutting AB at X and AC at Y . If $AB = 4BX$ and $YC = 2 \text{ cm}$, then $AY =$
(a) 2 cm (b) 6 cm (c) 8 cm (d) 4 cm
8. Two poles of height 6 m and 11 m stand vertically upright on a plane ground. If the distance between their foot is 12 m, the distance between their tops is
(a) 14 cm (b) 12 cm (c) 13 cm (d) 11 cm
9. If D, E, F are midpoints of sides BC, CA and AB respectively of $\triangle ABC$, then the ratio of the areas of triangles DEF and ABC is
(a) 2 : 3 (b) 1 : 4 (c) 1 : 2 (d) 4 : 5
10. If $\triangle ABC$ and $\triangle DEF$ are two triangles such that $\frac{AB}{DE} = \frac{BC}{EF} = \frac{CA}{FD} = \frac{2}{5}$, then $\frac{ar(\triangle ABC)}{ar(\triangle DEF)} =$
(a) 2 : 5 (b) 4 : 25 (c) 4 : 15 (d) 8 : 125
11. In triangles ABC and DEF , $\angle A = \angle E = 40^\circ$, $AB : ED = AC : EF$ and $\angle F = 65^\circ$, then $\angle B =$
(a) 35° (b) 65° (c) 75° (d) 85°
12. If ABC and DEF are similar triangles such that $\angle A = 47^\circ$ and $\angle E = 83^\circ$, then $\angle C =$
(a) 50° (b) 60° (c) 70° (d) 80°

PRACTICE QUESTIONS
CLASS X : CHAPTER - 6
TRIANGLES

1. State whether the following pairs of polygons are similar or not:

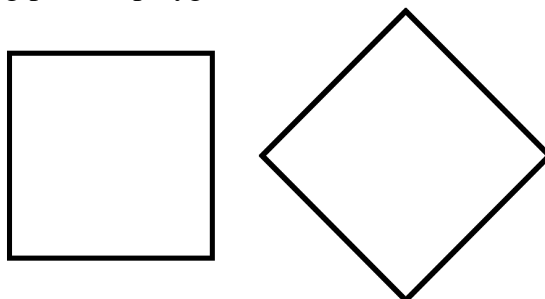

2. In triangle ABC, $DE \parallel BC$ and $\frac{AD}{DB} = \frac{3}{5}$. If $AC = 4.8$ cm, find AE.
3. A girl of height 90 cm is walking away from the base of a lamp post at a speed of 1.2m/s. If the lamp is 3.6 m above the ground, find the length of her shadow after 4 seconds.
4. Diagonals of a trapezium ABCD with $AB \parallel CD$ intersect at O. If $AB = 2CD$, find the ratio of areas of triangles AOB and COD.
5. Prove that the areas of two similar triangles are in the ratio of squares of their corresponding altitudes.
6. In the below figure, the line segment XY is parallel to side AC of $\triangle ABC$ and it divides the triangle into two equal parts of equal areas. Find the ratio $\frac{AX}{AB}$.

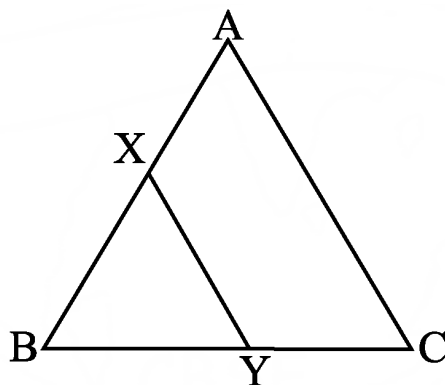

7. In a triangle, if square of one side is equal to the sum of the squares of the other two sides, then the angle opposite the first side is a right angle. Prove it.
8. E is a point on the side AD produced of a ||gm ABCD and BE intersects CD at F. Show that $\triangle ABE \sim \triangle CFB$.
9. Complete the sentence: Two polygons of the same number of sides are similar if.....
10. In $\triangle ABC$, $AD \perp BC$. Prove that $AB^2 - BD^2 = AC^2 - CD^2$.
11. AD is a median of $\triangle ABC$. The bisector of $\angle ADB$ and $\angle ADC$ meet AB and AC in E and F respectively. Prove that $EF \parallel BC$.

12. State and prove the Basic Proportionality theorem. In the below figure, if $LM \parallel CB$ and $LN \parallel CD$, prove that $\frac{AM}{AB} = \frac{AN}{AD}$.

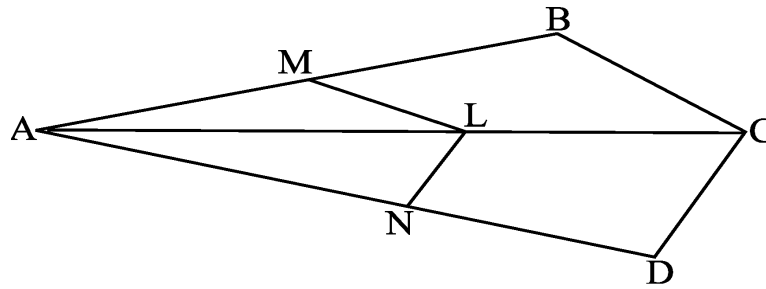

13. In the below figure, $DE \parallel BC$, find EC

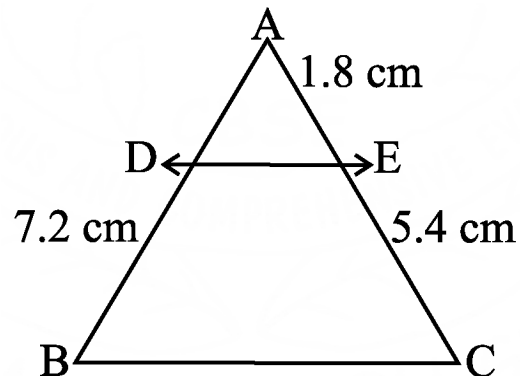
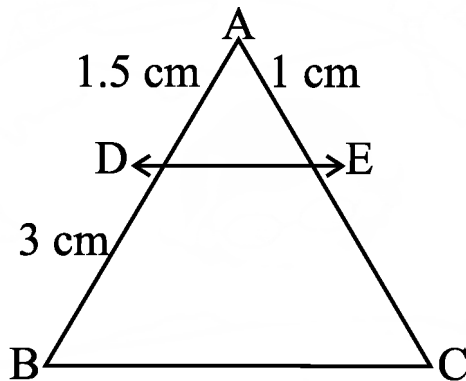

14. In the above right sided figure, $DE \parallel BC$, find AD.

15. In given figure $\frac{AD}{DB} = \frac{AE}{EC}$ and $\angle AED = \angle ABC$. Show that $AB = AC$

16. $\triangle ABC \sim \triangle DEF$, such that $\text{ar}(\triangle ABC) = 64 \text{ cm}^2$ and $\text{ar}(\triangle DEF) = 121 \text{ cm}^2$. If $EF = 15.4 \text{ cm}$, find BC.

17. ABC and BDE are two equilateral triangles such that D is the midpoint of BC. What is the ratio of the areas of triangles ABC and BDE.

18. Sides of 2 similar triangles are in the ratio 4 : 9. What is the ratio areas of these triangles.

19. Sides of a triangle are 7cm, 24 cm, 25 cm. Will it form a right triangle? Why or why not?

20. Find $\angle B$ in $\triangle ABC$, if $AB = 6\sqrt{3} \text{ cm}$, $AC = 12 \text{ cm}$ and $BC = 6 \text{ cm}$.

21. Prove that “If a line is drawn parallel to one side of a triangle to intersect the other two sides in distinct points, the other two sides are divided in the same ratio”.

22. Prove that “If a line divides any two sides of a triangle in the same ratio, then the line is parallel to the third side.”

23. If a line intersects sides AB and AC of a $\triangle ABC$ at D and E respectively and is parallel to BC, prove that $\frac{AD}{AB} = \frac{AE}{AC}$

24. ABCD is a trapezium in which $AB \parallel DC$ and its diagonals intersect each other at the point O. Show that $\frac{AO}{BO} = \frac{CO}{DO}$

25. Prove that “If in two triangles, corresponding angles are equal, then their corresponding sides are in the same ratio (or proportion) and hence the two triangles are similar.
26. Prove that “If one angle of a triangle is equal to one angle of the other triangle and the sides including these angles are proportional, then the two triangles are similar.
27. Prove that “If in two triangles, sides of one triangle are proportional to (i.e., in the same ratio of) the sides of the other triangle, then their corresponding angles are equal and hence the two triangles are similar.
28. D is a point on the side BC of a triangle ABC such that $\angle ADC = \angle BAC$. Show that $CA^2 = CB \cdot CD$.
29. Sides AB and BC and median AD of a triangle ABC are respectively proportional to sides PQ and QR and median PM of ΔPQR . Show that $\Delta ABC \sim \Delta PQR$.
30. Sides AB and AC and median AD of a triangle ABC are respectively proportional to sides PQ and PR and median PM of another triangle PQR. Show that $\Delta ABC \sim \Delta PQR$.
31. If AD and PM are medians of triangles ABC and PQR, respectively where $\Delta ABC \sim \Delta PQR$, prove that $\frac{AB}{PQ} = \frac{AD}{PM}$
32. A vertical pole of length 6 m casts a shadow 4 m long on the ground and at the same time a tower casts a shadow 28 m long. Find the height of the tower.
33. Prove that “The ratio of the areas of two similar triangles is equal to the square of the ratio of their corresponding sides.”
34. If the areas of two similar triangles are equal, prove that they are congruent.
35. D, E and F are respectively the mid-points of sides AB, BC and CA of ΔABC . Find the ratio of the areas of ΔDEF and ΔABC .
36. Prove that the ratio of the areas of two similar triangles is equal to the square of the ratio of their corresponding medians.
37. Prove that the area of an equilateral triangle described on one side of a square is equal to half the area of the equilateral triangle described on one of its diagonals.
38. Prove that “If a perpendicular is drawn from the vertex of the right angle of a right triangle to the hypotenuse then triangles on both sides of the perpendicular are similar to the whole triangle and to each other.”
39. Prove that “In a right triangle, the square of the hypotenuse is equal to the sum of the squares of the other two sides.
40. O is any point inside a rectangle ABCD. Prove that $OB^2 + OD^2 = OA^2 + OC^2$.
41. Prove that the sum of the squares of the sides of a rhombus is equal to the sum of the squares of its diagonals.

42. In Fig., if $AD \perp BC$, prove that $AB^2 + CD^2 = BD^2 + AC^2$.

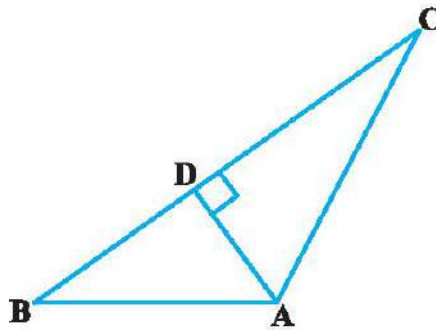

43. BL and CM are medians of a triangle ABC right angled at A. Prove that $4(BL^2 + CM^2) = 5 BC^2$.
44. An aeroplane leaves an airport and flies due north at a speed of 1000 km per hour. At the same time, another aeroplane leaves the same airport and flies due west at a speed of 1200 km per hour. How far apart will be the two planes after $1\frac{1}{2}$ hours?
45. D and E are points on the sides CA and CB respectively of a triangle ABC right angled at C. Prove that $AE^2 + BD^2 = AB^2 + DE^2$.
46. The perpendicular from A on side BC of a $\triangle ABC$ intersects BC at D such that $DB = 3 CD$. Prove that $2AB^2 = 2AC^2 + BC^2$.
47. In an equilateral triangle ABC, D is a point on side BC such that $BD = \frac{1}{3} BC$. Prove that $9AD^2 = 7AB^2$.
48. P and Q are the points on the sides DE and DF of a triangle DEF such that $DP = 5$ cm, $DE = 15$ cm, $DQ = 6$ cm and $QF = 18$ cm. Is $PQ \parallel EF$? Give reasons for your answer.
49. Is the triangle with sides 25 cm, 5 cm and 24 cm a right triangle? Give reasons for your answer.
50. It is given that $\triangle DEF \sim \triangle RPQ$. Is it true to say that $\angle D = \angle R$ and $\angle F = \angle P$? Why?
51. A and B are respectively the points on the sides PQ and PR of a triangle PQR such that $PQ = 12.5$ cm, $PA = 5$ cm, $BR = 6$ cm and $PB = 4$ cm. Is $AB \parallel QR$? Give reasons for your answer.
52. In the below Figure, BD and CE intersect each other at the point P. Is $\triangle PBC \sim \triangle PDE$? Why?

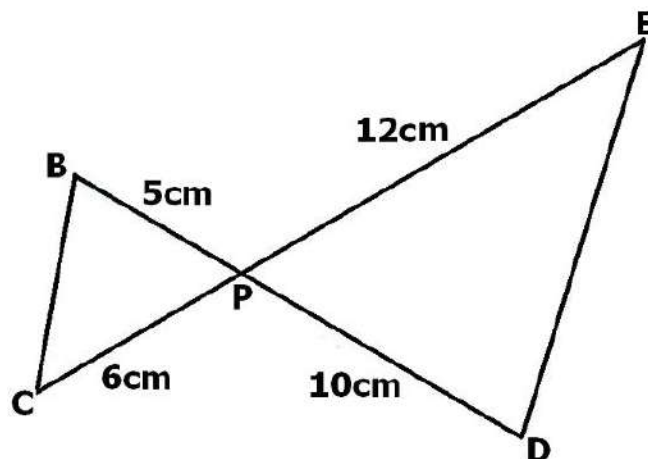

53. In triangles PQR and MST, $\angle P = 55^\circ$, $\angle Q = 25^\circ$, $\angle M = 100^\circ$ and $\angle S = 25^\circ$. Is $\triangle PQR \sim \triangle TSM$? Why?

54. Is the following statement true? Why? “Two quadrilaterals are similar, if their corresponding angles are equal”.
55. Two sides and the perimeter of one triangle are respectively three times the corresponding sides and the perimeter of the other triangle. Are the two triangles similar? Why?
56. If in two right triangles, one of the acute angles of one triangle is equal to an acute angle of the other triangle, can you say that the two triangles will be similar? Why?
57. The ratio of the corresponding altitudes of two similar triangles is 3 : 5. Is it correct to say that ratio of their areas is 6 : 5 ? Why?
58. D is a point on side QR of ΔPQR such that $PD \perp QR$. Will it be correct to say that $\Delta PQD \sim \Delta RPD$? Why?
59. Is it true to say that if in two triangles, an angle of one triangle is equal to an angle of another triangle and two sides of one triangle are proportional to the two sides of the other triangle, then the triangles are similar? Give reasons for your answer
60. Legs (sides other than the hypotenuse) of a right triangle are of lengths 16cm and 8 cm. Find the length of the side of the largest square that can be inscribed in the triangle.
61. In the below Figure, $\angle D = \angle E$ and $\frac{AD}{DB} = \frac{AE}{EC}$. Prove that BAC is an isosceles triangle.

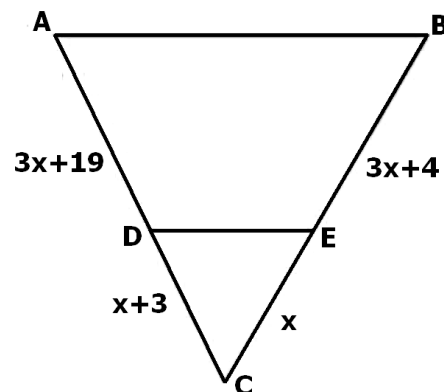
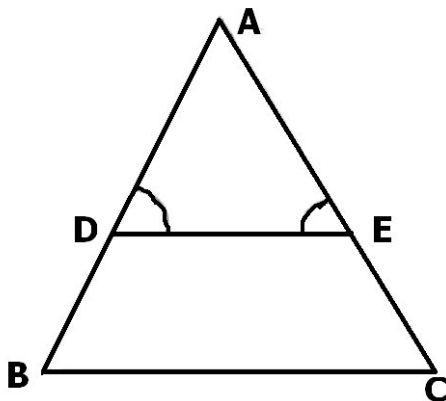

62. Find the value of x for which $DE \parallel AB$ in the above right sided Figure.
63. In a ΔPQR , $PR^2 - PQ^2 = QR^2$ and M is a point on side PR such that $QM \perp PR$. Prove that $QM^2 = PM \times MR$.
64. Hypotenuse of a right triangle is 25 cm and out of the remaining two sides, one is longer than the other by 5 cm. Find the lengths of the other two sides.
65. Diagonals of a trapezium PQRS intersect each other at the point O, $PQ \parallel RS$ and $PQ = 3 RS$. Find the ratio of the areas of triangles POQ and ROS.
66. Find the altitude of an equilateral triangle of side 8 cm.
67. If $\Delta ABC \sim \Delta DEF$, $AB = 4$ cm, $DE = 6$ cm, $EF = 9$ cm and $FD = 12$ cm, find the perimeter of ΔABC .

68. In the below figure, if $AB \parallel DC$ and AC and PQ intersect each other at the point O , prove that $OA \cdot CQ = OC \cdot AP$.

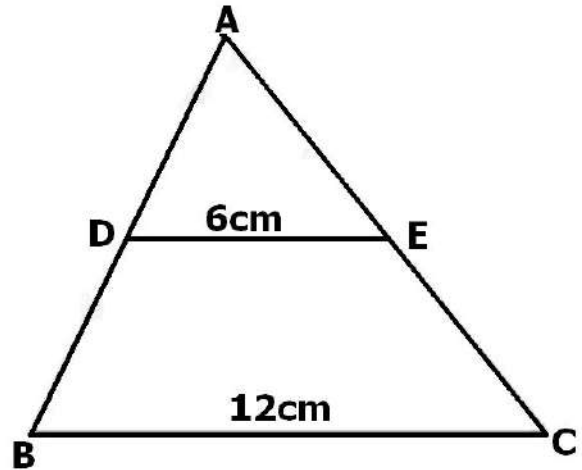
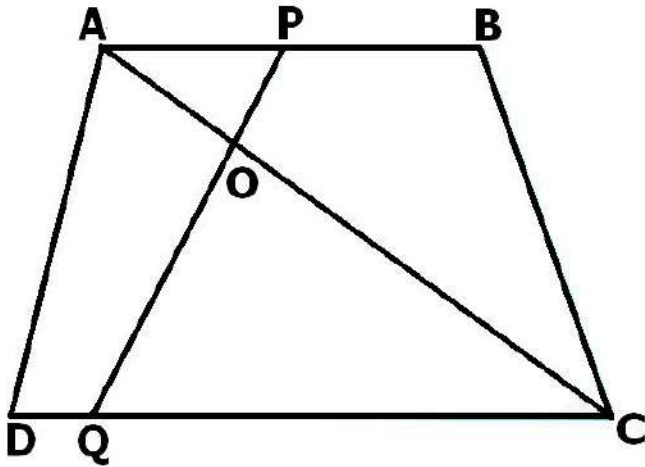

69. In the above right sided Figure, if $DE \parallel BC$, find the ratio of ar (ADE) and ar (DECB).
70. ABCD is a trapezium in which $AB \parallel DC$ and P and Q are points on AD and BC , respectively such that $PQ \parallel DC$. If $PD = 18$ cm, $BQ = 35$ cm and $QC = 15$ cm, find AD .
71. Corresponding sides of two similar triangles are in the ratio of $2 : 3$. If the area of the smaller triangle is 48 cm^2 , find the area of the larger triangle.
72. In a triangle PQR , N is a point on PR such that $QN \perp PR$. If $PN \cdot NR = QN^2$, prove that $\angle PQR = 90^\circ$.
73. A 15 metres high tower casts a shadow 24 metres long at a certain time and at the same time, a telephone pole casts a shadow 16 metres long. Find the height of the telephone pole.
74. Areas of two similar triangles are 36 cm^2 and 100 cm^2 . If the length of a side of the larger triangle is 20 cm, find the length of the corresponding side of the smaller triangle.
75. Foot of a 10 m long ladder leaning against a vertical wall is 6 m away from the base of the wall. Find the height of the point on the wall where the top of the ladder reaches.
76. An aeroplane leaves an Airport and flies due North at 300 km/h. At the same time, another aeroplane leaves the same Airport and flies due West at 400 km/h. How far apart the two aeroplanes would be after $1\frac{1}{2}$ hours?
77. It is given that $\triangle ABC \sim \triangle EDF$ such that $AB = 5$ cm, $AC = 7$ cm, $DF = 15$ cm and $DE = 12$ cm. Find the lengths of the remaining sides of the triangles.
78. A 5 m long ladder is placed leaning towards a vertical wall such that it reaches the wall at a point 4 m high. If the foot of the ladder is moved 1.6 m towards the wall, then find the distance by which the top of the ladder would slide upwards on the wall.
79. In a triangle PQR , $PD \perp QR$ such that D lies on QR . If $PQ = a$, $PR = b$, $QD = c$ and $DR = d$, prove that $(a + b)(a - b) = (c + d)(c - d)$.

80. In the below Figure, if $\angle ACB = \angle CDA$, $AC = 8$ cm and $AD = 3$ cm, find BD .

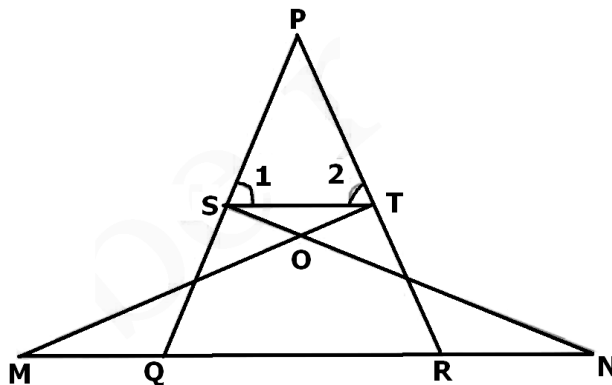
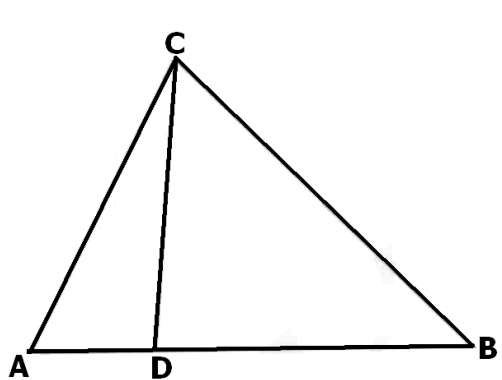

81. In the above right sided Figure, if $\angle 1 = \angle 2$ and $\triangle NSQ \cong \triangle MTR$, then prove that $\triangle PTS \sim \triangle PRQ$.

82. In the below Figure, OB is the perpendicular bisector of the line segment DE , $FA \perp OB$ and $F E$ intersects OB at the point C . Prove that $\frac{1}{OA} + \frac{1}{OB} = \frac{2}{OC}$

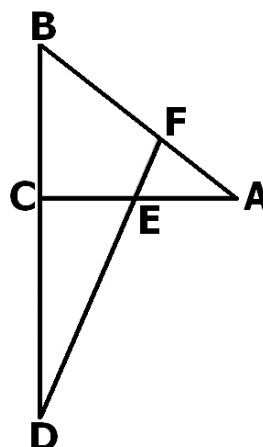
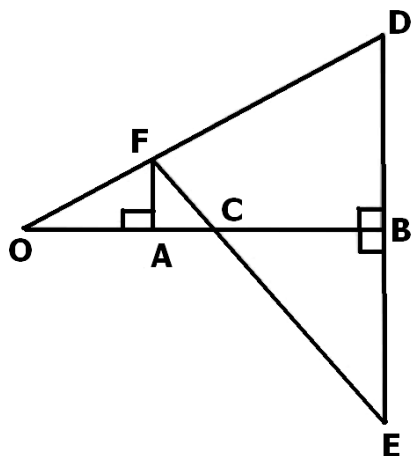

83. In the above right sided figure, line segment DF intersect the side AC of a triangle ABC at the point E such that E is the mid-point of CA and $\angle AEF = \angle AFE$. Prove that $\frac{BD}{CD} = \frac{BF}{CE}$.

84. In the below figure, if $\triangle ABC \sim \triangle DEF$ and their sides are of lengths (in cm) as marked along them, then find the lengths of the sides of each triangle.

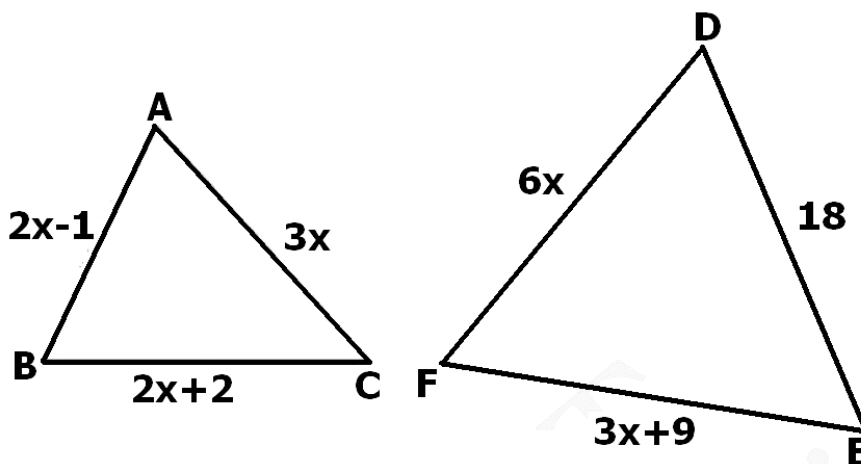

85. In the below figure, $l \parallel m$ and line segments AB, CD and EF are concurrent at point P. Prove that

$$\frac{AE}{BF} = \frac{AC}{BD} = \frac{CE}{FD}$$

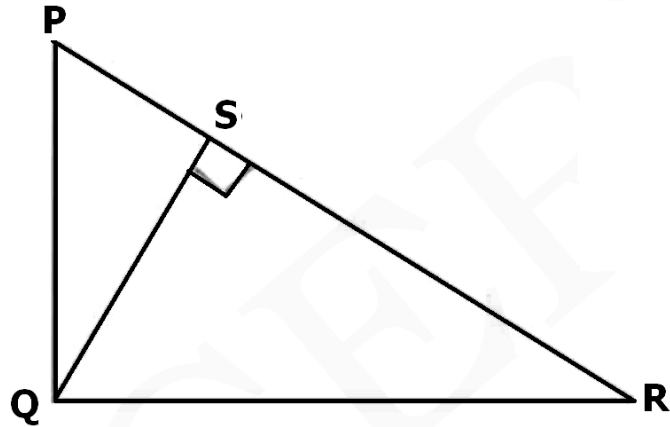
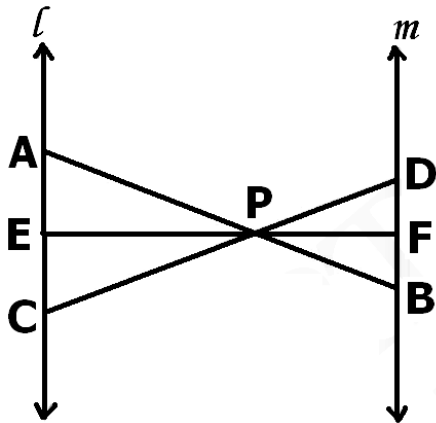

86. In the above right sided figure, PQR is a right triangle right angled at Q and $QS \perp PR$. If $PQ = 6$ cm and $PS = 4$ cm, find QS, RS and QR.

87. For going to a city B from city A, there is a route via city C such that $AC \perp CB$, $AC = 2x$ km and $CB = 2(x + 7)$ km. It is proposed to construct a 26 km highway which directly connects the two cities A and B. Find how much distance will be saved in reaching city B from city A after the construction of the highway.

88. In the below figure, ABC is a triangle right angled at B and $BD \perp AC$. If $AD = 4$ cm and $CD = 5$ cm, find BD and AB.

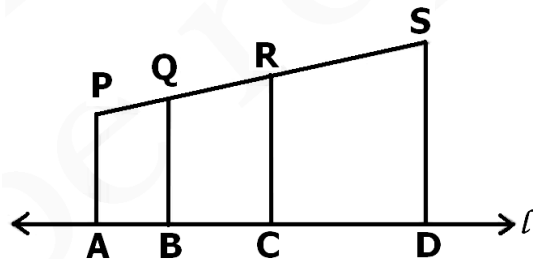
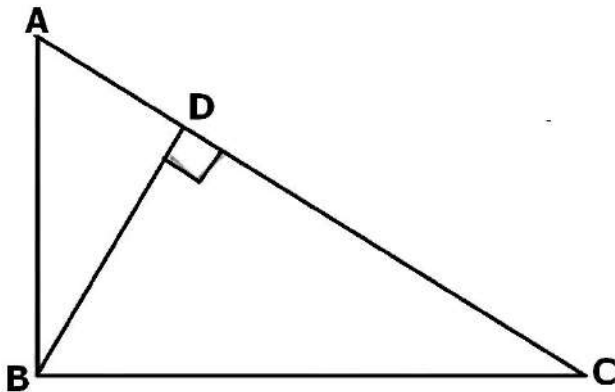

89. In the above right sided figure, PA, QB, RC and SD are all perpendiculars to a line l , $AB = 6$ cm, $BC = 9$ cm, $CD = 12$ cm and $SP = 36$ cm. Find PQ, QR and RS.

90. In a quadrilateral ABCD, $\angle A = \angle D = 90^\circ$. Prove that $AC^2 + BD^2 = AD^2 + BC^2 + 2 \cdot CD \cdot AB$

91. A flag pole 18 m high casts a shadow 9.6 m long. Find the distance of the top of the pole from the far end of the shadow.

92. A street light bulb is fixed on a pole 6 m above the level of the street. If a woman of height 1.5 m casts a shadow of 3m, find how far she is away from the base of the pole.

93. O is the point of intersection of the diagonals AC and BD of a trapezium ABCD with $AB \parallel DC$. Through O, a line segment PQ is drawn parallel to AB meeting AD in P and BC in Q. Prove that $PO = QO$.

94. Prove that the internal bisector of an angle of a triangle divides the opposite side in the ratio of the sides containing the angle.
95. Prove that the area of the semicircle drawn on the hypotenuse of a right angled triangle is equal to the sum of the areas of the semicircles drawn on the other two sides of the triangle.
96. Using Thales theorem, prove that a line drawn through the mid-point of one side of a triangle parallel to another side bisects the third side.
97. Using Converse of Thales theorem, prove that the line joining the mid-points of any two sides of a triangle is parallel to the third side.
98. In the below figure A, B and C are points on OP, OQ and OR respectively such that $AB \parallel PQ$ and $AC \parallel PR$. Show that $BC \parallel QR$.

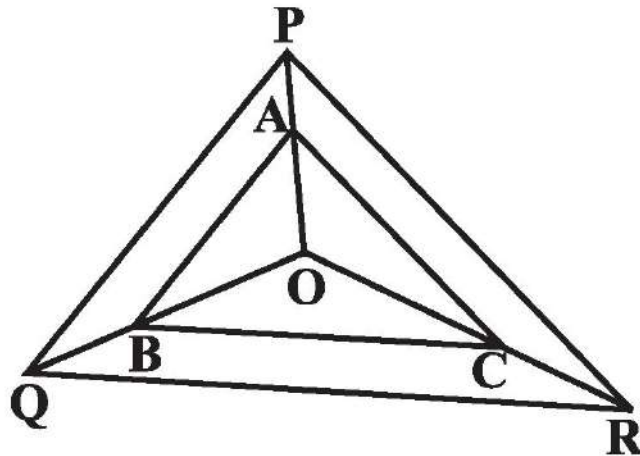

99. In the below figure, if $\angle A = \angle C$, $AB = 6$ cm, $BP = 15$ cm, $AP = 12$ cm and $CP = 4$ cm, then find the lengths of PD and CD.

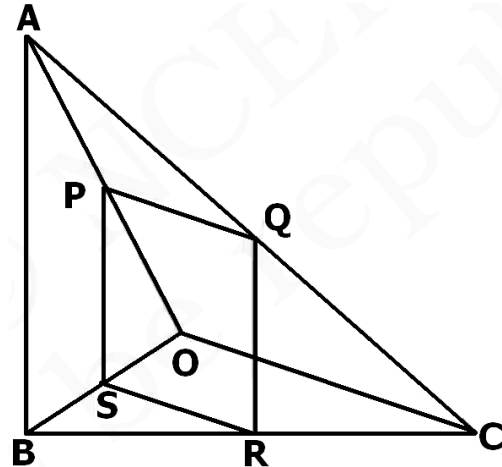
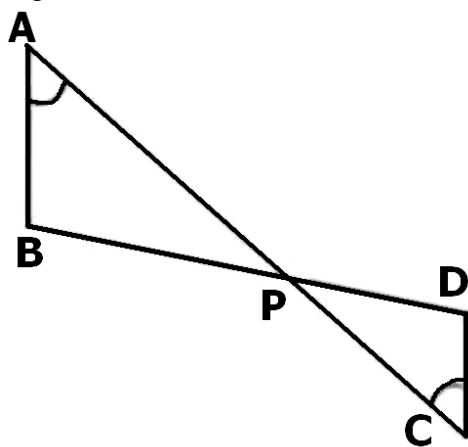

100. In the above right sided figure, if PQRS is a parallelogram, $AB \parallel PS$ and $PQ \parallel OC$, then prove that $OC \parallel SR$.

CLASS X : CHAPTER - 7 COORDINATE GEOMETRY

IMPORTANT FORMULAS & CONCEPTS

Points to remember

- ☞ The distance of a point from the y -axis is called its **x -coordinate**, or **abscissa**.
- ☞ The distance of a point from the x -axis is called its **y -coordinate**, or **ordinate**.
- ☞ The coordinates of a point on the x -axis are of the form $(x, 0)$.
- ☞ The coordinates of a point on the y -axis are of the form $(0, y)$.

Distance Formula

The distance between any two points $A(x_1, y_1)$ and $B(x_2, y_2)$ is given by

$$AB = \sqrt{(x_2 - x_1)^2 + (y_2 - y_1)^2}$$

or $AB = \sqrt{(\text{difference of abscissae})^2 + (\text{difference of ordinates})^2}$

Distance of a point from origin

The distance of a point $P(x, y)$ from origin O is given by $OP = \sqrt{x^2 + y^2}$

Problems based on geometrical figure

To show that a given figure is a

- ☞ Parallelogram – prove that the opposite sides are equal
- ☞ Rectangle – prove that the opposite sides are equal and the diagonals are equal.
- ☞ Parallelogram but not rectangle – prove that the opposite sides are equal and the diagonals are not equal.
- ☞ Rhombus – prove that the four sides are equal
- ☞ Square – prove that the four sides are equal and the diagonals are equal.
- ☞ Rhombus but not square – prove that the four sides are equal and the diagonals are not equal.
- ☞ Isosceles triangle – prove any two sides are equal.
- ☞ Equilateral triangle – prove that all three sides are equal.
- ☞ Right triangle – prove that sides of triangle satisfies Pythagoras theorem.

Section formula

The coordinates of the point $P(x, y)$ which divides the line segment joining the points $A(x_1, y_1)$ and $B(x_2, y_2)$, internally, in the ratio $m_1 : m_2$ are

$$\left(\frac{m_1 x_2 + m_2 x_1}{m_1 + m_2}, \frac{m_1 y_2 + m_2 y_1}{m_1 + m_2} \right)$$

This is known as the **section formula**.

Mid-point formula

The coordinates of the point $P(x, y)$ which is the midpoint of the line segment joining the points

$A(x_1, y_1)$ and $B(x_2, y_2)$, are $\left(\frac{x_1 + x_2}{2}, \frac{y_1 + y_2}{2} \right)$

Area of a Triangle

If A(x₁, y₁), B(x₂, y₂) and C(x₃, y₃) are the vertices of a ΔABC, then the area of ΔABC is given by

$$\text{Area of } \Delta ABC = \frac{1}{2}[x_1(y_2 - y_3) + x_2(y_3 - y_1) + x_3(y_1 - y_2)]$$

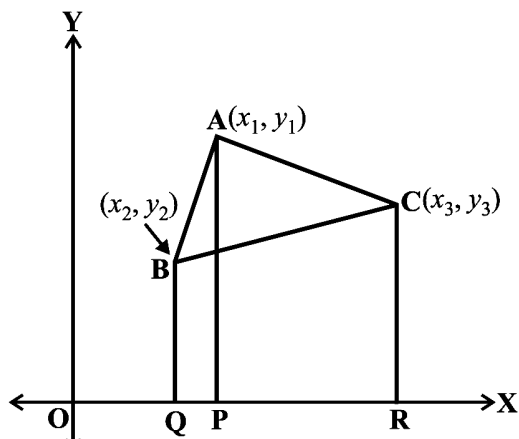

Trick to remember the formula

The formula of area of a triangle can be learn with the help of following arrow diagram:

$$\Delta ABC = \frac{1}{2} \begin{vmatrix} x_1 & y_1 \\ x_2 & y_2 \\ x_3 & y_3 \\ x_1 & y_1 \end{vmatrix}$$

Find the sum of products of numbers at the ends of the lines pointing downwards and then subtract the sum of products of numbers at the ends of the line pointing upwards, multiply the difference by

$$\frac{1}{2} \text{ .e. Area of } \Delta ABC = \frac{1}{2}[(x_1y_2 + x_2y_3 + x_3y_1) - (x_1y_3 + x_3y_2 + x_2y_1)]$$



MCQ WORKSHEET-I
CLASS X: CHAPTER – 7
COORDINATE GEOMETRY

1. The points A(0, -2), B(3, 1), C(0, 4) and D(-3, 1) are the vertices of a
(a) parallelogram (b) rectangle (c) square (d) rhombus
2. If A(3, 8), B(4, -2) and C(5, -1) are the vertices of $\triangle ABC$. Then, its area is
(a) $28\frac{1}{2}$ sq. units (b) $37\frac{1}{2}$ sq. units (c) 57 sq. units (d) 75 sq. units
3. The points A(0, 6), B(-5, 3) and C(3, 1) are the vertices of a triangle which is
(a) isosceles (b) equilateral (c) scalene (d) right angled
4. Two vertices of $\triangle ABC$ are A(-1, 4) and B(5, 2) and its centroid is G(0, -3). The coordinate of C is
(a) (4, 3) (b) (4, 15) (c) (-4, -15) (d) (-15, -4)
5. The coordinates of the centroid of $\triangle ABC$ with vertices A(-1, 0), B(5, -2) and C(8, 2) is
(a) (12, 0) (b) (6, 0) (c) (0, 6) (d) (4, 0)
6. If the points A(2, 3), B(5, k) and C(6, 7) are collinear, then the value of k is
(a) 4 (b) 6 (c) $-\frac{3}{2}$ (d) $\frac{11}{4}$
7. If P(-1, 1) is the middle point of the line segment joining A(-3, b) and B(1, b + 4) then the value of b is
(a) 1 (b) -1 (c) 2 (d) 0
8. y-axis divides the join of P(-4, 2) and Q(8, 3) in the ratio
(a) 3 : 1 (b) 1 : 3 (c) 2 : 1 (d) 1 : 2
9. x-axis divides the join of A(2, -3) and B(5, 6) in the ratio
(a) 3 : 5 (b) 2 : 3 (c) 2 : 1 (d) 1 : 2
10. The point P(1, 2) divides the join of A(-2, 1) and B(7, 4) are in the ratio of
(a) 3 : 2 (b) 2 : 3 (c) 2 : 1 (d) 1 : 2
11. A point P divides the join of A(5, -2) and B(9, 6) are in the ratio 3 : 1. The coordinates of P are
(a) (4, 7) (b) (8, 4) (c) $(\frac{11}{2}, 5)$ (d) (12, 8)
12. What point on x – axis is equidistant from the points A(7, 6) and B(-3, 4)?
(a) (0, 4) (b) (-4, 0) (c) (3, 0) (d) (0, 3)
13. The distance of the point P(4, -3) from the origin is
(a) 1 unit (b) 7 units (c) 5 units (d) 3 units
14. The distance between the points A(2, -3) and B(2, 2) is
(a) 2 units (b) 4 units (c) 5 units (d) 3 units
15. Find the area of the triangle whose vertices are A(1, 2), B(-2, 3) and C(-3, -4)
(a) 11sq. units (b) 22 sq. units (c) 7 sq. units (d) 6.5 sq. units

MCQ WORKSHEET-II
CLASS X: CHAPTER – 7
COORDINATE GEOMETRY

1. Find the area of the triangle whose vertices are A(2, 4), B(-3, 7) and C(-4, 5)
(a) 11sq. units (b) 22 sq. units (c) 7 sq. units (d) 6.5 sq. units
2. Find the area of the triangle whose vertices are A(10, -6), B(2, 5) and C(-1, 3)
(a) 12.5 sq. units (b) 24.5 sq. units (c) 7 sq. units (d) 6.5 sq. units
3. Find the area of the triangle whose vertices are A(4, 4), B(3, -16) and C(3, -2)
(a) 12.5 sq. units (b) 24.5 sq. units (c) 7 sq. units (d) 6.5 sq. units
4. For what value of x are the points A(-3, 12), B(7, 6) and C(x, 9) collinear?
(a) 1 (b) -1 (c) 2 (d) -2
5. For what value of y are the points A(1, 4), B(3, y) and C(-3, 16) collinear?
(a) 1 (b) -1 (c) 2 (d) -2
6. Find the value of p for which the points A(-1, 3), B(2, p) and C(5, -1) collinear?
(a) 1 (b) -1 (c) 2 (d) -2
7. What is the midpoint of a line with endpoints (-3, 4) and (10, -5)?
(a) (-13, -9) (b) (-6.5, -4.5) (c) (3.5, -0.5) (d) none of these
8. A straight line is drawn joining the points (3, 4) and (5,6). If the line is extended, the ordinate of the point on the line, whose abscissa is -1 is
(a) 1 (b) -1 (c) 2 (d) 0
9. If the distance between the points (8, p) and (4, 3) is 5 then value of p is
(a) 6 (b) 0 (c) both (a) and (b) (d) none of these
10. The fourth vertex of the rectangle whose three vertices taken in order are (4,1), (7, 4), (13, -2) is
(a) (10, -5) (b) (10, 5) (c) (8, 3) (d) (8, -3)
11. If four vertices of a parallelogram taken in order are (-3, -1), (a, b), (3, 3) and (4, 3). Then a : b =
(a) 1 : 4 (b) 4 : 1 (c) 1 : 2 (d) 2 : 1
12. Area of the triangle formed by (1, - 4), (3, - 2) and (- 3,16) is
(a) 40 sq. units (b) 48 sq. units (c) 24 sq. units (d) none of these
13. The points (2, 5), (4, - 1), (6, - 7) are vertices of an _____ triangle
(a) isosceles (b) equilateral (c) scalene (d) right angled
14. The area of triangle formed by the points (p, 2 - 2p), (1-p,2p) and (-4-p, 6- 2p) is 70 sq. units. How many integral value of p are possible ?
(a) 2 (b) 3 (c) 4 (d) none of these
15. If the origin is the mid-point of the line segment joined by the points (2,3) and (x,y), then the value of (x,y) is
(a) (2, -3) (b) (2, 3) (c) (-2, 3) (d) (-2, -3)

MCQ WORKSHEET-III
CLASS X: CHAPTER – 7
COORDINATE GEOMETRY

1. The distance of the point P(2, 3) from the x-axis is:
(a) 2 (b) 3 (c) 1 (d) 5
2. The distance between the points A(0, 6) and B(0, -2) is:
(a) 2 (b) 6 (c) 4 (d) 8
3. The distance of the point P(-6, 8) from the origin is:
(a) 8 (b) 27 (c) 10 (d) 6
4. The distance between the points (0, 5) and (-5, 0) is:
(a) 5 (b) 52 (c) 25 (d) 10
5. AOBC is a rectangle whose three vertices are A(0, 3), O(0, 0) and B(5, 0). The length of its diagonal is:
(a) 5 (b) 3 (c) 34 (d) 4
6. The perimeter of a triangle with vertices (0, 4), (0, 0) and (3, 0) is:
(a) 5 (b) 12 (c) 11 (d) 7 + 5
7. The area of a triangle with vertices A(3, 0), B(7, 0) and C(8, 4) is:
(a) 14 (b) 28 (c) 8 (d) 6
8. The points (-4, 0), (4, 0), (0, 3) are the vertices of a :
(a) Right triangle (b) Isosceles triangle (c) Equilateral triangle (d) Scalene triangle
9. Point on x – axis has coordinates:
(a) (a, 0) (b) (0, a) (c) (-a, a) (d) (a, -a)
10. Point on y – axis has coordinates:
(a) (-a, b) (b) (a, 0) (c) (0, b) (d) (-a, -b)
11. Line formed by joining (- 1,1) and (5, 7) is divided by a line $x + y = 4$ in the ratio of
(a) 1 : 4 (b) 1 : 3 (c) 1 : 2 (d) 3 : 4
12. If the area of the triangle with vertices (x, 0), (1,1) and (0, 2) is 4 square units, then a value of x is
(a) -2 (b) -4 (c) -6 (d) 8

MCQ WORKSHEET-IV
CLASS X: CHAPTER – 7
COORDINATE GEOMETRY

1. Point A(-5, 6) is at a distance of:
(a) 61 units from the origin (b) 11 units from the origin
(c) $\sqrt{61}$ units from the origin (d) $\sqrt{11}$ units from the origin
2. If the points (1, x), (5, 2) and (9, 5) are collinear then the value of x is
(a) $\frac{5}{2}$ (b) $\frac{-5}{2}$ (c) -1 (d) 1
3. The end points of diameter of circle are (2, 4) and (-3, -1). The radius of the circle is
(a) $\frac{5\sqrt{2}}{2}$ (b) $5\sqrt{2}$ (c) $3\sqrt{2}$ (d) $\frac{\pm 5\sqrt{2}}{2}$
4. The ratio in which x – axis divides the line segment joining the points (5, 4) and (2, -3) is:
(a) 5 : 2 (b) 3 : 4 (c) 2 : 5 (d) 4 : 3
5. The point which divides the line segment joining the points (7, -6) and (3, 4) in ratio 1:2 internally lies in the
(a) I quadrant (b) II quadrant (c) III quadrant (d) IV quadrant
6. The point which lies on the perpendicular bisector of the line segment joining the points A(-2, -5) and B(2, 5) is:
(a) (0, 0) (b) (0, 2) (c) (2, 0) (d) (-2, 0)
7. The fourth vertex D of a parallelogram ABCD whose three vertices are A(-2, 3), B(6, 7) and C(8, 3) is:
(a) (0, 1) (b) (0, -1) (c) (-1, 0) (d) (1, 0)
8. If the point P(2, 1) lies on the line segment joining points A(4, 2) and B(8, 4), then
(a) $AP = \frac{1}{3} AB$ (b) $AP = PB$ (c) $PB = \frac{1}{3} AB$ (d) $AP = \frac{1}{2} AB$
9. Three vertices of a parallelogram taken in order are (-1, -6), (2, -5) and (7, 2). The fourth vertex is
(a) (1, 4) (b) (1, 1) (c) (4, 4) (d) (4, 1)
10. If A and B are the points (-3, 4) and (2, 1) respectively, then the coordinates of the points on AB produced such that $AC = 2BC$ are
(a) (2, 4) (b) (3, 7) (c) (7, -2) (d) none of these
11. Distance of the point (4, a) from x-axis is half its distance from y-axis then a =
(a) 2 (b) 8 (c) 4 (d) 6
12. A triangle is formed by the points O(0, 0), A(5, 0) and B(0, 5). The number of points having integral coordinates (both x and y) and strictly inside the triangle is
(a) 10 (b) 17 (c) 16 (d) 6

13. If P(1, 2), Q(4,6), R(5,7) and S(a, b) are the vertices of a parallelogram PQRS then
(a) $a = 2, b = 4$ (b) $a = 3, b = 4$ (c) $a = 2, b = 3$ (d) $a = 3, b = 5$
14. The number of points on x-axis which are at a distance of 2 units from (2, 4) is
(a) 2 (b) 1 (c) 3 (d) 0
15. The distance of the point (h, k) from x-axis is
(a) h (b) k (c) $|h|$ (d) $|k|$
16. The vertices of a triangle are (0, 0), (3, 0) and (0, 4). Its orthocentre is at
(a) (0, 3) (b) (4, 0) (c) (0, 0) (d) (3, 4)
17. The area of the triangle with vertices at the points (a, b + c), (b, c + a) and (c, a + b) is
(a) $a + b + c$ (b) $a + b - c$ (c) $a - b + c$ (d) 0
18. If the segment joining the points (a, b) and (c, d) subtends a right angle at the origin, then
(a) $ac - bd = 0$ (b) $ac + bd = 0$ (c) $ab - cd = 0$ (d) $ab + cd = 0$
19. The distance of A(5, -12) from the origin is
(a) 12 (b) 11 (c) 13 (d) 10
20. Find the ordinate of a point whose abscissa is 10 and which is at a distance of 10 units from the point P(2, -3).
(a) 3 (b) -9 (c) both (a) or (b) (d) none of these
-

PRACTICE QUESTIONS
CLASS X : CHAPTER – 7
COORDINATE GEOMETRY
DISTANCE FORMULA

1. Find the distance between the following points:
(i) A(9, 3) and (15, 11) (ii) A(7, -4) and b(-5, 1).
(iii) A(-6, -4) and B(9, -12) (iv) A(1, -3) and B(4, -6)
(v) P(a + b, a - b) and Q(a - b, a + b)
(vi) P(a sin α , a cos α) and Q(a cos α , -asin α)
2. If A(6, -1), B(1, 3) and C(k, 8) are three points such that AB= BC, find the value of k.
3. Find all the possible value of a for which the distance between the points A(a, -1) and B(5, 3) is 5 units.
4. Determine, whether each of the given points (-2, 1), (2, -2) and (5, 2) are the vertices of right angle.
5. Determine if the points (1, 5), (2, 3) and (-2, -11) are collinear.
6. By distance formula, show that the points (1, -1), (5, 2) and (9, 5) are collinear.
7. Find the value of k if the points A(2, 3), B(4, k) and C(6, -3) are collinear.
8. Find a relation between x and y if the points (x, y), (1, 2) and (7, 0) are collinear.
9. Find the point on x-axis which is equidistant from (-2, 5) and (2, -3).
10. Find the point on x-axis which is equidistant from (7, 6) and (-3, 4).
11. Find the point on the x-axis which is equidistant from (2, -5) and (-2, 9).
12. Find a point on the y-axis which is equidistant from the points A(6, 5) and B(-4, 3).
13. Find a point on the y-axis which is equidistant from the points A(5, 2) and B(-4, 3).
14. Find a point on the y-axis which is equidistant from the points A(5, -2) and B(-3, 2).
15. Find the point on y-axis, each of which is at a distance of 13 units from the point (-5, 7).
16. Find the point on x-axis, each of which is at a distance of 10 units from the point (11, -8).
17. Find the values of k for which the distance between the points A(k, -5) and B(2, 7) is 13 units.
18. Prove that the points A(-3, 0), B(1, -3) and C(4, 1) are the vertices of an isosceles right-angled triangle. Find the area of this triangle.
19. Prove that the points A(a, a), B(-a, -a) and C(- $\sqrt{3}$ a, $\sqrt{3}$ a) are the vertices of an equilateral triangle. Calculate the area of this triangle.

20. If the distance of $P(x, y)$ from $A(5, 1)$ and $B(-1, 5)$ are equal. Prove that $3x = 2y$.
21. Show that the points $A(1, 2)$, $B(5, 4)$, $C(3, 8)$ and $D(-1, 6)$ are vertices of a square.
22. Show that the points $A(5, 6)$, $B(1, 5)$, $C(2, 1)$ and $D(6, 2)$ are vertices of a square.
23. Show that the points $A(0, -2)$, $B(3, 1)$, $C(0, 4)$ and $D(-3, 1)$ are vertices of a square. Also find its area.
24. Show that the points $A(6, 2)$, $B(2, 1)$, $C(1, 5)$ and $D(5, 6)$ are vertices of a square. Also find its area.
25. Show that the points $A(-4, -1)$, $B(-2, -4)$, $C(4, 0)$ and $D(2, 3)$ are vertices of a rectangle. Also find its area.
26. Prove that the points $A(2, -2)$, $B(14, 10)$, $C(11, 13)$ and $D(-1, 1)$ are vertices of a rectangle. Find the area of this rectangle.
27. Show that the points $A(1, -3)$, $B(13, 9)$, $C(10, 12)$ and $D(-2, 0)$ are vertices of a rectangle.
28. Show that the points $A(1, 0)$, $B(5, 3)$, $C(2, 7)$ and $D(-2, 4)$ are vertices of a rhombus.
29. Prove that the points $A(2, -1)$, $B(3, 4)$, $C(-2, 3)$ and $D(-3, -2)$ are vertices of a rhombus. Find the area of this rhombus.
30. Show that the points $A(-3, 2)$, $B(-5, -5)$, $C(2, -3)$ and $D(4, 4)$ are vertices of a rhombus. Find the area of this rhombus.
31. Prove that the points $A(-2, -1)$, $B(1, 0)$, $C(4, 3)$ and $D(1, 2)$ are vertices of a parallelogram.
32. Find the area of a rhombus if its vertices are $(3, 0)$, $(4, 5)$, $(-1, 4)$ and $(-2, -1)$ taken in order.
33. Find the coordinates of the circumcentre of a triangle whose vertices are $A(4, 6)$, $B(0, 4)$ and $C(6, 2)$. Also, find its circumradius.
34. Find the coordinates of the circumcentre of a triangle whose vertices are $A(3, 0)$, $B(-1, -6)$ and $C(4, -1)$. Also, find its circumradius.
35. Find the coordinates of the circumcentre of a triangle whose vertices are $A(8, 6)$, $B(8, -2)$ and $C(2, -2)$. Also, find its circumradius.
36. Find the coordinates of the centre of a circle passing through the points $A(2, 1)$, $B(5, -8)$ and $C(2, -9)$. Also find the radius of this circle.
37. Find the coordinates of the centre of a circle passing through the points $A(-2, -3)$, $B(-1, 0)$ and $C(7, -6)$. Also find the radius of this circle.
38. Find the coordinates of the centre of a circle passing through the points $A(1, 2)$, $B(3, -4)$ and $C(5, -6)$. Also find the radius of this circle.
39. Find the coordinates of the centre of a circle passing through the points $A(0, 0)$, $B(-2, 1)$ and $C(-3, 2)$. Also find the radius of this circle.
40. Find the centre of a circle passing through the points $(6, -6)$, $(3, -7)$ and $(3, 3)$.

41. Find the coordinates of the point equidistant from three given points A(5, 3), B(5, -5) and C(1, -5).
42. If the points A(6, 1), B(8, 2), C(9, 4) and D(p, 3) are the vertices of a parallelogram, taken in order, find the value of p.
43. Find a relation between x and y such that the point (x, y) is equidistant from the points (7, 1) and (3, 5).
44. Check whether (5, -2), (6, 4) and (7, -2) are the vertices of an isosceles triangle.
45. Find the values of y for which the distance between the points P(2, -3) and Q(10, y) is 10 units.
46. If Q(0, 1) is equidistant from P(5, -3) and R(x, 6), find the values of x. Also find the distances QR and PR.
47. If two vertices of an equilateral triangle be O(0, 0) and A(3, $\sqrt{3}$), find the coordinates of its third vertex.
48. The two opposite vertices of a square are (-1, 2) and (3, -2). Find the coordinates of the other two vertices.
49. The two opposite vertices of a square are (1, -6) and (5, 4). Find the coordinates of the other two vertices.
50. Prove that the points A(7, 10), B(-2, 5) and C(3, -4) are the vertices of an isosceles right triangle.
51. Show that the points A(-5, 6), B(3, 0) and C(9, 8) are the vertices of an isosceles right angled triangle. Find the area of this triangle.
52. Show that the points A(2, 1), B(5, 2), C(6, 4) and D(3, 3) are the angular points of parallelogram. Is this figure a rectangle?
53. Show that the points O(0, 0), A(3, $\sqrt{3}$) and B(3, $-\sqrt{3}$) are the vertices of an equilateral triangle. Find the area of this triangle.
54. Prove that the points A(3, 0), B(6, 4) and C(-1, 3) are the vertices of a right triangle. Also prove that these are vertices of an isosceles triangle.
55. If P and Q are two points whose coordinates are $(at^2, 2at)$ and $\left(\frac{a}{t^2}, \frac{2a}{t}\right)$ respectively and S is the point (a, 0). Show that $\frac{1}{SP} + \frac{1}{SQ}$ is independent of t.
56. If the points A(4, 3) and B(x, 5) are on the circle with centre O(2, 3), find the value of x.
57. Find the relation between x and y if point P(x, y) lies on the perpendicular bisector of the line joining the points (3, 6) and (-3, 4).

58. Find the relation between x and y if point $P(x, y)$ lies on the perpendicular bisector of the line joining the points $(7, 1)$ and $(3, 5)$.
59. If A, B and P are the points $(-4, 3), (0, -2)$ and (α, β) respectively and P is equidistant from A and B , show that $8\alpha - 10\beta + 21 = 0$.
60. If the points $(5, 4)$ and (x, y) are equidistant from the point $(4, 5)$, prove that $x^2 + y^2 - 8x - 10y + 39 = 0$.
61. Find the coordinates of the point which is at a distance of 2 units from $(5, 4)$ and 10 units from $(11, -2)$.
62. If two vertices of an equilateral triangle are $(0, 0)$ and $(3, 0)$, find the third vertex.
63. The centre of a circle is $(2\alpha-1, 3\alpha+1)$ and it passes through the point $(-3, -1)$. If a diameter of the circle is of length 20 units, find the value of α .
64. If the point $P(x, y)$ is equidistant from the points $A(5, 1)$ and $B(-1, 5)$, prove that $x = y$.
65. Find the value of k if the point $P(0, 2)$ is equidistant from $(3, k)$ and $(k, 5)$.
66. Let the opposite angular points of a square be $(3, 4)$ and $(1, -1)$. Find the coordinates of the remaining angular points.
67. Prove that the points $(2x, 4a), (2a, 6a)$ and $(2a + \sqrt{3}a, 5a)$ are the vertices of an equilateral triangle.
68. An equilateral triangle has two vertices at the points $(3, 4)$ and $(-2, 3)$, find the coordinates of the third vertex.
69. Two vertex of an isosceles triangle are $(2, 0)$ and $(2, 5)$. Find the third vertex if the length of the equal sides is 3.
70. The coordinates of the point P are $(-3, 2)$. Find the coordinates of the point Q which lies on the line joining P and origin such that $OP = OQ$.



PRACTICE QUESTIONS
CLASS X : CHAPTER – 7
COORDINATE GEOMETRY
SECTION FORMULA

1. Find the coordinates of the point which divides the line segment joining the points A(4, -3) and B(9, 7) in the ratio 3 : 2.
2. Find the coordinates of the point which divides the line segment joining the points A(-1, 7) and B(4, -3) in the ratio 2 : 3.
3. Find the coordinates of the point which divides the line segment joining the points A(-5, 11) and B(4, -7) in the ratio 7 : 2.
4. Find the coordinates of the midpoint of the line segment joining the points A(-5, 4) and B(7, -8)
5. Find the coordinates of the midpoint of the line segment joining the points A(3, 0) and B(5, 4)
6. Find the coordinates of the midpoint of the line segment joining the points A(-11, -8) and B(8, -2).
7. The coordinates of the midpoint of the line segment joining the points A(2p + 1, 4) and B(5, q-1) are(2p, q). Find the value of p and q.
8. The midpoint of the line segment joining A(2a, 4) and B(-2, 3b) is M(1, 2a + 1). Find the values of a and b.
9. Find the coordinates of the points which divide the line segment joining the points (-2, 0) and (0, 8) in four equal parts.
10. Find the coordinates of the points which divide the line segment joining the points (-2, 2) and (2, 8) in four equal parts.
11. In what ratio does the points P(2,-5) divide the line segment joining A(-3, 5) and B(4, -9).
12. In what ratio does the points P(2, 5) divide the line segment joining A(8, 2) and B(-6, 9).
13. Find the coordinates of the points of trisection of the line segment joining the points (4, -1) and (-2, -3).
14. The line segment joining the points (3, -4) and (1, 2) is trisected at the points P(p, -2) and Q($\frac{5}{3}$, q). Find the values of p and q.
15. The coordinate of the midpoint of the line joining the point (3p, 4) and (-2, 2q) are (5, p). Find the value of p and q.
16. The consecutive vertices of a parallelogram ABCD are A(1, 2), B(1, 0) and C(4, 0). Find the fourth vertex D.
17. Find the lengths of the median of the triangle whose vertices are (1, -1), (0, 4) and (-5, 3).
18. Prove that the diagonal of a rectangle bisect each other and are equal.

19. Find the ratio in which the point (11, 15) divides the line segment joining the point (15, 5) and (9, 20).
20. Find the ratio in which the point P(m, 6) divides the line segment joining the point A(-4, 3) and B(2, 8). Also find the value of m.
21. If two vertices of ΔABC are A(3, 2), B(-2, 1) and its centroid G has the coordinate $(\frac{5}{3}, -\frac{1}{3})$. Find the coordinates of the third vertex.
22. The coordinate of the midpoint of the line joining the point (2p, 4) and (-2, 2q) are (3, p). Find the value of p and q.
23. Show that the points A(3, 1), B(0, -2), C(1, 1) and D(4, 4) are the vertices of a parallelogram ABCD.
24. If the points P(a, -11), Q(5, b), R(2, 15) and S(1, 1) are the vertices of a parallelogram PQRS, find the value of a and b.
25. If three consecutive vertices of a parallelogram ABCD are A(1, -2), B(3, 6) and C(5, 10). Find the fourth vertex D.
26. In what ratio does the point (-4, 6) divide the line segment joining the points A(-6, 10) and B(3, -8)?
27. Find the coordinates of the points of trisection of the line segment joining the points A(2, -2) and B(-7, 4).
28. Find the ratio in which the y-axis divides the line segment joining the points (5, -6) and (-1, -4). Also find the point of intersection.
29. If the points A(6, 1), B(8, 2), C(9, 4) and D(p, 3) are the vertices of a parallelogram, taken in order, find the value of p.
30. If the points A(-2, -1), B(a, 0), C(4, b) and D(1, 2) are the vertices of a parallelogram, taken in order, find the value of a and b.
31. Find the ratio in which the point P(-6, a) divides the join of A(-3, -1) and B(-8, 9). Also, find the value of a.
32. Find the ratio in which the point P(-3, a) divides the join of A(-5, -4) and B(-2, 3). Also, find the value of a.
33. Find the ratio in which the point P(a, 1) divides the join of A(-4, 4) and B(6, -1). Also, find the value of a.
34. Find the ratio in which the line segment joining the points (-3, 10) and (6, -8) is divided by (-1, 6).
35. Find the ratio in which the line segment joining A(1, -5) and B(-4, 5) is divided by the x-axis. Also find the coordinates of the point of division.
36. In what ratio is the line segment joining A(6, -3) and B(-2, -5) is divided by the x-axis. Also find the coordinates of the point of intersection of AB and the x-axis.

37. In what ratio is the line segment joining $A(2, -3)$ and $B(5, 6)$ is divided by the x -axis. Also find the coordinates of the point of intersection of AB and the x -axis.
38. In what ratio is the line segment joining $A(-2, -3)$ and $B(3, 7)$ is divided by the y -axis. Also find the coordinates of the point of intersection of AB and the y -axis.
39. The coordinates of one end point of a diameter AB of a circle are $A(4, -1)$ and the coordinates of the centre of the circle are $C(1, -3)$.
40. Find the coordinates of a point A , where AB is the diameter of a circle whose centre is $(2, -3)$ and B is $(1, 4)$.
41. The line segment joining $A(-2, 9)$ and $B(6, 3)$ is a diameter of a circle with centre C . Find the coordinates of C .
42. AB is a diameter of a circle with centre $C(-1, 6)$. If the coordinates of A are $(-7, 3)$, find the coordinates of B .
43. Find the ratio in which the line $2x + y - 4 = 0$ divides the line segment joining the points $A(2, -2)$ and $B(3, 7)$.
44. Find the ratio in which the line $x - y - 2 = 0$ divides the line segment joining the points $A(3, -1)$ and $B(8, 9)$.
45. Find the ratio in which the line $3x + 4y - 9 = 0$ divides the line segment joining the points $A(1, 3)$ and $B(2, 7)$.
46. Find the lengths of the medians of a triangle ABC whose vertices are $A(7, -3)$, $B(5, 3)$ and $C(3, -1)$.
47. Find the lengths of the medians of a triangle ABC whose vertices are $A(0, -1)$, $B(2, 1)$ and $C(0, 3)$.
48. Let $D(3, -2)$, $E(-3, 1)$ and $F(4, -3)$ be the midpoints of the sides BC , CA and AB respectively of $\triangle ABC$. Then, find the coordinates if the vertices A , B and C .
49. If A and B are $(-2, -2)$ and $(2, -4)$, respectively, find the coordinates of P such that $AP = \frac{3}{7} AB$ and P lies on the line segment AB .
50. $A(1, 1)$ and $B(2, -3)$ are two points. If C is a point lying on the line segment AB such that $CB = 2AC$, find the coordinates of C .
51. If $A(1, 1)$ and $B(-2, 3)$ are two points and C is a point on AB produced such that $AC = 3AB$, find the coordinates of C .
52. Find the coordinates of the point P which is three-fourth of the way from $A(3, 1)$ to $B(-2, 5)$.
53. The line joining the points $A(4, -5)$ and $B(4, 5)$ is divided by the point P such that $AP : AB = 2 : 5$, find the coordinates of P .
54. The point $P(-4, 1)$ divides the line segment joining the points $A(2, -2)$ and B in the ratio $3 : 5$. Find the point B .

55. If A and B are (4, -5) and (4, 5), respectively, find the coordinates of P such that $AP = \frac{2}{5} AB$ and P lies on the line segment AB.
56. Find the coordinates of the points of trisection of the line segment AB, whose end points are A(2, 1) and B(5, -8).
57. Find the coordinates of the points which divide the join A(-4, 0) and B(0, 6) in three equal parts.
58. The line joining the points A(2, 1) and B(5, -8) is trisected at the points P and Q. If the point P lies on the line $2x - y + k = 0$, find the value of k.
59. Find the coordinates of the points which divide the line segment joining A(-2, 2) and B(2, 8) into four equal parts.
60. If A(5, -1), B(-3, -2) and C(-1, 8) are the vertices of ΔABC , find the length of the median through A and the coordinates of the centroid.
61. Find the centroid of ΔABC whose vertices are vertices are A(-3, 0), B(5, -2) and C(-8, 5).
62. Two vertices of a ΔABC are given by A(6, 4) and B(-2, 2) and its centroid is G(3, 4). Find the coordinates of the third vertex C of ΔABC .
63. Find the coordinates of the centroid of a ΔABC whose vertices are A(6, -2), B(4, -3) and C(-1, -4).
64. Find the centroid of a ΔABC whose vertices are A(-1, 0), B(5, -2) and C(8, 2).
65. A(3, 2) and B(-2, 1) are two vertices of a ΔABC , whose centroid is $G(\frac{5}{3}, \frac{-1}{3})$. Find the coordinates of the third vertex C.
66. If G(-2, 1) is the centroid of ΔABC and two of its vertices are A(1, -6) and B(-5, 2), find the third vertex of the triangle.
67. Find the third vertex of a ΔABC if two of its vertices are B(-3, 1) and C(0, -2) and its centroid is at the origin.
68. The line segment joining $A(-1, \frac{5}{3})$ and B(a, 5) is divided in the ratio 1 : 3 at P, the point where the line segment AB intersects y-axis. Find the value of a and the coordinates of P.
69. Find the ratio in which the point P whose ordinate is -3 divides the join of A(-2, 3) and B(5, $\frac{-15}{2}$). Hence find the coordinate of P.
70. Calculate the ratio in which the line joining the points A(6, 5) and B(4, -3) is divided by the line $y = 2$. Also, find the coordinates of the point of intersection.
71. Show that the points (3, -2), (5, 2) and (8, 8) are collinear by using section formula.

72. If the points $(-1, -1)$, $(2, p)$ and $(8, 11)$ are collinear, find the value of p using section formula.
73. If the points $(2, 3)$, $(4, k)$ and $(6, -3)$ are collinear, find the value of k using section formula.
74. If two vertices of a parallelogram are $(3, 2)$, $(-1, 0)$ and its diagonals meet at $(2, -5)$, find the other two vertices of the parallelogram.
75. Find the coordinates of the vertices of a triangle whose midpoints are $(-3, 2)$, $(1, -2)$ and $(5, 6)$.
76. Find the third vertex of a triangle if its two vertices are $(-1, 4)$ and $(5, 2)$ and midpoint of one side is $(0, 3)$.
77. If the midpoints of the sides of a triangle are $(2, 3)$, $(\frac{3}{2}, 4)$ and $(\frac{11}{2}, 5)$, find the centroid of the triangle.
78. If the points $(10, 5)$, $(8, 4)$ and $(6, 6)$ are the midpoints of the sides of a triangle, find its vertices.
79. If the point $C(-1, 2)$ divides the line segment AB in the ratio $3 : 4$, where the coordinates of A are $(2, 5)$, find the coordinates of B .
80. The vertices of a quadrilateral are $(1, 4)$, $(-2, 1)$, $(0, -1)$ and $(3, 2)$. Show that diagonals bisect each other. What does quadrilateral become?
81. Using analytical geometry, prove that the midpoint of the hypotenuse of a right triangle is equidistant from its vertices.
82. Using analytical geometry, prove that the diagonals of a rhombus are perpendicular to each other.
83. Prove analytically that the line segment joining the midpoint of two sides of a triangle is half of the third side.
84. If $(-2, 3)$, $(4, -3)$ and $(4, 5)$ are the midpoints of the sides of a triangle, find the coordinates of its centroid.
85. If $(1, 1)$, $(2, -3)$ and $(3, 4)$ are the midpoints of the sides of a triangle, find the coordinates of its centroid.
-

PRACTICE QUESTIONS
CLASS X : CHAPTER – 7
COORDINATE GEOMETRY
AREA OF TRIANGLE

1. Find the area of a triangle formed by the points A(5, 2), B(4, 7) and C(7, - 4).
2. Find the area of a triangle formed by the points A(1, -1), B(- 4, 6) and C(- 3, - 5).
3. Find the area of a triangle formed by the points A(2, 3), B(- 1, 0) and C(2, -4).
4. Find the area of a triangle formed by the points A(10, -6), B(2, 5) and C(- 1, 3).
5. Determine if the points (1, 5), (2, 3) and (- 2, - 11) are collinear.
6. Show that the points $(\frac{-3}{2}, 3)$, (6, -2), (-3, 4) are collinear by using area of triangle.
7. By using area of triangle show that the points (a, b + c), (b, c + a) and (c, a + b) are collinear.
8. Find the value of k if the points A(8, 1), B(k , -4) and C(2, -5) are collinear.
9. Find the value of k if the points A(7, -2), B(5, 1) and C(3, k) are collinear.
10. If A(3, 2), B(-1, 0) and C(1, -12) are the vertices of a triangle and D is midpoint of BC, find the coordinates of the point D. Also find the areas of $\triangle ABD$ and $\triangle ACD$. Hence verify that the median AD divides the triangle ABC into two triangles of equal areas.
11. Find the value of k if the points A(2, 3), B(4, k) and C(6, -3) are collinear.
12. If A(-5, 7), B(- 4, -5), C(-1, -6) and D(4, 5) are the vertices of a quadrilateral, find the area of the quadrilateral ABCD.
13. If A(2, 1), B(6, 0), C(5, -2) and D(-3, -1) are the vertices of a quadrilateral, find the area of the quadrilateral ABCD.
14. If A(-4, 5), B(0, 7), C(5, -5) and D(-4, -2) are the vertices of a quadrilateral, find the area of the quadrilateral ABCD.
15. If A(0, 0), B(6, 0), C(4, 3) and D(0, 3) are the vertices of a quadrilateral, find the area of the quadrilateral ABCD.
16. If A(-4, -2), B(-3, -5), C(3, -2) and D(2, 3) are the vertices of a quadrilateral, find the area of the quadrilateral ABCD.
17. Find the area of the triangle formed by joining the mid-points of the sides of the triangle whose vertices are (0, -1), (2, 1) and (0, 3). Find the ratio of this area to the area of the given triangle.
18. Find a relation between x and y if the points (x , y), (1, 2) and (7, 0) are collinear.

19. If A(2, 1), B(-2, 3) and C(4, -3) are the vertices of a ΔABC and D, E are the midpoints of the sides AB, AC respectively, find the coordinates of D and E. Prove that the area of ΔABC is four times the area of ΔADE .
20. If A(4, 4), B(3, -16) and C(3, -2) are the vertices of a ΔABC and D, E, F are the midpoints of the sides BC, CA and AB respectively. Prove that the area of ΔABC is four times the area of ΔDEF .
21. Find the point P on the x – axis which is equidistant from the points A(5, 4) and B(-2, 3). Also find the area of ΔPAB .
22. If P(x, y) is any point on the line joining the points A(a, 0) and B(0, b), then show that $\frac{x}{a} + \frac{y}{b} = 1$.
23. If the vertices of a triangle are (1, k), (4, -3) and (-9, 7) and its area is 15 sq. units, find the value(s) of k.
24. Find the value of m for which the points with coordinates (3, 5), (m, 6) and $\left(\frac{1}{2}, \frac{15}{2}\right)$ are collinear.
25. Find the value of k for which the points with coordinates (2, 5), (4, 6) and $\left(k, \frac{11}{2}\right)$ are collinear.
26. Find the point P on x-axis which is equidistant from A(-2, 5) and B(2, -3). Also find the area of ΔPAB .
27. Find the point P on x-axis which is equidistant from A(7, 6) and B(-3, 4). Also find the area of ΔPAB .
28. Find the point P on the x-axis which is equidistant from A(2, -5) and B(-2, 9). Also find the area of ΔPAB .
29. Find a point P on the y-axis which is equidistant from the points A(6, 5) and B(-4, 3). Also find the area of ΔPAB .
30. Find a point P on the y-axis which is equidistant from the points A(5, 2) and B(-4, 3). Also find the area of ΔPAB .
31. Find a point P on the y-axis which is equidistant from the points A(5, -2) and B(-3, 2). Also find the area of ΔPAB .
32. Find the value of k for which the area formed by the triangle with vertices A(k, 2k), (-2, 6) and C(3, 1) is 5 square units.
33. Find the value of k for which the area formed by the triangle with vertices A(1, 2), (-2, 3) and C(-3, k) is 11 square units.
34. Find the value of k for which the area formed by the triangle with vertices A(4, 4), (3, k) and C(3, -2) is 7 square units.
35. For what value of p are the points A(-3, 9), B(2, p) and C(4, -5) are collinear.

36. Prove that the area of triangle whose vertices are $(t, t - 2)$, $(t + 2, t + 2)$ and $(t + 3, t)$ is independent of t .
37. For what value of k are the points $(k, 2 - 2k)$, $(-k + 1, 2k)$ and $(-4 - k, 6 - 2k)$ are collinear.
38. Find the condition that the point (x, y) may lie on the line joining $(3, 4)$ and $(-5, -6)$.
39. If the coordinates of two points A and B are $(3, 4)$ and $(5, -2)$ respectively. Find the coordinates of any point P, if $PA = PB$ and area of $\Delta PAB = 10$ sq. units.
40. The coordinates of A, B, C are $(6, 3)$, $(-3, 5)$ and $(4, -2)$ respectively and P is any point (x, y) . Show that the ratio of the areas of triangles PBC and ABC is $\left| \frac{x + y - 2}{7} \right|$.
41. If (x, y) be on the line joining the two points $(1, -3)$ and $(-4, 2)$, prove that $x + y + 2 = 0$.
42. Prove that the points (a, b) , (x, y) and $(a - x, b - y)$ are collinear if $ay = bx$.
43. Four points A(6, 3), B(-3, 5), C(4, -2) and D(x, 3x) are given in such a way that $\frac{\Delta DBC}{\Delta ABC} = \frac{1}{2}$, find the value of x .
44. If three points (a, b) , (c, d) and (e, f) are collinear, prove that $\frac{d - f}{ce} + \frac{f - b}{ea} + \frac{b - d}{ac} = 0$.
45. The area of triangle is 5 sq. units. Two of its vertices are $(2, 1)$ and $(3, -2)$. The third vertex lies on $y = x + 3$. Find the third vertex.
-

CLASS X: CHAPTER - 8
INTRODUCTION TO TRIGONOMETRY

IMPORTANT FORMULAS & CONCEPTS

The word 'trigonometry' is derived from the Greek words 'tri' (meaning three), 'gon' (meaning sides) and 'metron' (meaning measure). In fact, **trigonometry** is the study of relationships between the sides and angles of a triangle.

Trigonometric Ratios (T - Ratios) of an acute angle of a right triangle

In XOY-plane, let a revolving line OP starting from OX, trace out $\angle XOP = \theta$.

From P (x, y) draw $PM \perp$ to OX.

In right angled triangle OMP. $OM = x$ (Adjacent side); $PM = y$ (opposite side); $OP = r$ (hypotenuse).

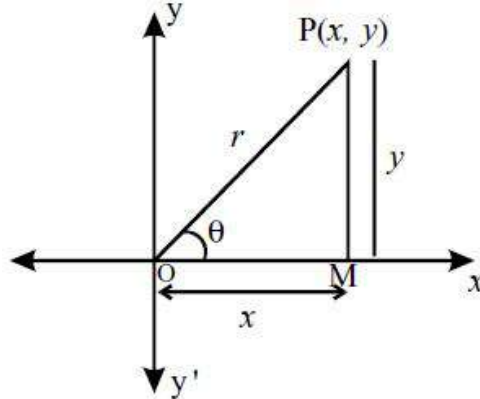

$$\begin{aligned} \sin \theta &= \frac{\text{Opposite side}}{\text{Hypotenuse}} = \frac{y}{r} & \operatorname{cosec} \theta &= \frac{\text{Hypotenuse}}{\text{Opposite side}} = \frac{r}{y} \\ \cos \theta &= \frac{\text{Adjacent Side}}{\text{Hypotenuse}} = \frac{x}{r} & \sec \theta &= \frac{\text{Hypotenuse}}{\text{Adjacent Side}} = \frac{r}{x} \\ \tan \theta &= \frac{\text{Opposite side}}{\text{Adjacent Side}} = \frac{y}{x} & \cot \theta &= \frac{\text{Adjacent Side}}{\text{Opposite side}} = \frac{x}{y} \end{aligned}$$

Reciprocal Relations

$$\begin{aligned} \sin \theta &= \frac{1}{\operatorname{cosec} \theta} & \operatorname{cosec} \theta &= \frac{1}{\sin \theta} \\ \cos \theta &= \frac{1}{\sec \theta} & \sec \theta &= \frac{1}{\cos \theta} \\ \tan \theta &= \frac{1}{\cot \theta} & \cot \theta &= \frac{1}{\tan \theta} \end{aligned}$$

Quotient Relations

$$\tan \theta = \frac{\sin \theta}{\cos \theta} \quad \text{and} \quad \cot \theta = \frac{\cos \theta}{\sin \theta}$$

- **Remark 1 :** sin q is read as the “sine of angle q” and it should never be interpreted as the product of ‘sin’ and ‘q’
- **Remark 2 : Notation :** $(\sin \theta)^2$ is written as $\sin^2 \theta$ (read “sin square q”) Similarly $(\sin \theta)^n$ is written as $\sin^n \theta$ (read “sin nth power q”), n being a positive integer.
- **Note :** $(\sin \theta)^2$ should not be written as $\sin \theta^2$ or as $\sin^2 \theta^2$
- **Remark 3 :** Trigonometric ratios depend only on the value of θ and are independent of the lengths of the sides of the right angled triangle.

Trigonometric ratios of Complementary angles.

$$\sin(90 - \theta) = \cos \theta$$

$$\cos(90 - \theta) = \sin \theta$$

$$\tan(90 - \theta) = \cot \theta$$

$$\cot(90 - \theta) = \tan \theta$$

$$\sec(90 - \theta) = \operatorname{cosec} \theta$$

$$\operatorname{cosec}(90 - \theta) = \sec \theta.$$

Trigonometric ratios for angle of measure.

$0^\circ, 30^\circ, 45^\circ, 60^\circ$ and 90° in tabular form.

$\angle A$	0°	30°	45°	60°	90°
sinA	0	$\frac{1}{2}$	$\frac{1}{\sqrt{2}}$	$\frac{\sqrt{3}}{2}$	1
cosA	1	$\frac{\sqrt{3}}{2}$	$\frac{1}{\sqrt{2}}$	$\frac{1}{2}$	0
tanA	0	$\frac{1}{\sqrt{3}}$	1	$\sqrt{3}$	Not defined
cosecA	Not defined	2	$\sqrt{2}$	$\frac{2}{\sqrt{3}}$	1
secA	1	$\frac{2}{\sqrt{3}}$	$\sqrt{2}$	2	Not defined
cotA	Not defined	$\sqrt{3}$	1	$\frac{1}{\sqrt{3}}$	0

TRIGONOMETRIC IDENTITIES

An equation involving trigonometric ratios of an angle is said to be a trigonometric identity if it is satisfied for all values of θ for which the given trigonometric ratios are defined.

Identity (1) : $\sin^2\theta + \cos^2\theta = 1$

$$\Rightarrow \sin^2\theta = 1 - \cos^2\theta \text{ and } \cos^2\theta = 1 - \sin^2\theta.$$

Identity (2) : $\sec^2\theta = 1 + \tan^2\theta$

$$\Rightarrow \sec^2\theta - \tan^2\theta = 1 \text{ and } \tan^2\theta = \sec^2\theta - 1.$$

Identity (3) : $\operatorname{cosec}^2\theta = 1 + \cot^2\theta$

$$\Rightarrow \operatorname{cosec}^2\theta - \cot^2\theta = 1 \text{ and } \cot^2\theta = \operatorname{cosec}^2\theta - 1.$$

SOME TIPS

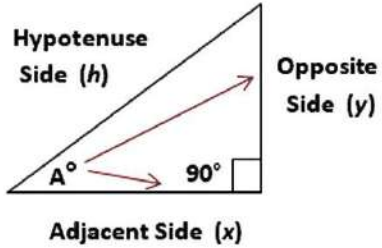
Right Triangle	SOH-CAH-TOA Method	Coordinate System Method
	<p>SOH: $\operatorname{sine}(A) = \sin(A) = \frac{\text{Opposite}}{\text{Hypotenuse}}$</p> <p>CAH: $\operatorname{cosine}(A) = \cos(A) = \frac{\text{Adjacent}}{\text{Hypotenuse}}$</p> <p>TOA: $\operatorname{tangent}(A) = \tan(A) = \frac{\text{Opposite}}{\text{Adjacent}}$</p> <p>$\operatorname{cosecant}(A) = \operatorname{csc}(A) = \frac{1}{\sin(A)} = \frac{\text{Hypotenuse}}{\text{Opposite}}$</p> <p>$\operatorname{secant}(A) = \operatorname{sec}(A) = \frac{1}{\cos(A)} = \frac{\text{Hypotenuse}}{\text{Adjacent}}$</p> <p>$\operatorname{cotangent}(A) = \operatorname{cot}(A) = \frac{1}{\tan(A)} = \frac{\text{Adjacent}}{\text{Opposite}}$</p>	<p>$\sin(A) = \frac{y}{h}$</p> <p>$\cos(A) = \frac{x}{h}$</p> <p>$\tan(A) = \frac{y}{x}$</p> <p>$\operatorname{csc}(A) = \frac{1}{\sin(A)} = \frac{h}{y}$</p> <p>$\operatorname{sec}(A) = \frac{1}{\cos(A)} = \frac{h}{x}$</p> <p>$\operatorname{cot}(A) = \frac{1}{\tan(A)} = \frac{x}{y}$</p>

Each trigonometric function in terms of the other five.

in terms of	$\sin \theta$	$\cos \theta$	$\tan \theta$	$\csc \theta$	$\sec \theta$	$\cot \theta$
$\sin \theta =$	$\sin \theta$	$\pm \sqrt{1 - \cos^2 \theta}$	$\pm \frac{\tan \theta}{\sqrt{1 + \tan^2 \theta}}$	$\frac{1}{\csc \theta}$	$\pm \frac{\sqrt{\sec^2 \theta - 1}}{\sec \theta}$	$\pm \frac{1}{\sqrt{1 + \cot^2 \theta}}$
$\cos \theta =$	$\pm \sqrt{1 - \sin^2 \theta}$	$\cos \theta$	$\pm \frac{1}{\sqrt{1 + \tan^2 \theta}}$	$\pm \frac{\sqrt{\csc^2 \theta - 1}}{\csc \theta}$	$\frac{1}{\sec \theta}$	$\pm \frac{\cot \theta}{\sqrt{1 + \cot^2 \theta}}$
$\tan \theta =$	$\pm \frac{\sin \theta}{\sqrt{1 - \sin^2 \theta}}$	$\pm \frac{\sqrt{1 - \cos^2 \theta}}{\cos \theta}$	$\tan \theta$	$\pm \frac{1}{\sqrt{\csc^2 \theta - 1}}$	$\pm \sqrt{\sec^2 \theta - 1}$	$\frac{1}{\cot \theta}$
$\csc \theta =$	$\frac{1}{\sin \theta}$	$\pm \frac{1}{\sqrt{1 - \cos^2 \theta}}$	$\pm \frac{\sqrt{1 + \tan^2 \theta}}{\tan \theta}$	$\csc \theta$	$\pm \frac{\sec \theta}{\sqrt{\sec^2 \theta - 1}}$	$\pm \sqrt{1 + \cot^2 \theta}$
$\sec \theta =$	$\pm \frac{1}{\sqrt{1 - \sin^2 \theta}}$	$\frac{1}{\cos \theta}$	$\pm \sqrt{1 + \tan^2 \theta}$	$\pm \frac{\csc \theta}{\sqrt{\csc^2 \theta - 1}}$	$\sec \theta$	$\pm \frac{\sqrt{1 + \cot^2 \theta}}{\cot \theta}$
$\cot \theta =$	$\pm \frac{\sqrt{1 - \sin^2 \theta}}{\sin \theta}$	$\pm \frac{\cos \theta}{\sqrt{1 - \cos^2 \theta}}$	$\frac{1}{\tan \theta}$	$\pm \sqrt{\csc^2 \theta - 1}$	$\pm \frac{1}{\sqrt{\sec^2 \theta - 1}}$	$\cot \theta$

Note: $\csc \theta$ is same as $\operatorname{cosec} \theta$.

MCQ WORKSHEET-I
CLASS X: CHAPTER - 8
INTRODUCTION TO TRIGONOMETRY

1. In $\triangle OPQ$, right-angled at P, $OP = 7$ cm and $OQ - PQ = 1$ cm, then the values of $\sin Q$.
(a) $\frac{7}{25}$ (b) $\frac{24}{25}$ (c) 1 (d) none of the these
2. If $\sin A = \frac{24}{25}$, then the value of $\cos A$ is
(a) $\frac{7}{25}$ (b) $\frac{24}{25}$ (c) 1 (d) none of the these
3. In $\triangle ABC$, right-angled at B, $AB = 5$ cm and $\angle ACB = 30^\circ$ then the length of the side BC is
(a) $5\sqrt{3}$ (b) $2\sqrt{3}$ (c) 10 cm (d) none of these
4. In $\triangle ABC$, right-angled at B, $AB = 5$ cm and $\angle ACB = 30^\circ$ then the length of the side AC is
(a) $5\sqrt{3}$ (b) $2\sqrt{3}$ (c) 10 cm (d) none of these
5. The value of $\frac{2 \tan 30^\circ}{1 + \tan^2 30^\circ}$ is
(a) $\sin 60^\circ$ (b) $\cos 60^\circ$ (c) $\tan 60^\circ$ (d) $\sin 30^\circ$
6. The value of $\frac{1 - \tan^2 45^\circ}{1 + \tan^2 45^\circ}$ is
(a) $\tan 90^\circ$ (b) 1 (c) $\sin 45^\circ$ (d) 0
7. $\sin 2A = 2 \sin A$ is true when $A =$
(a) 0° (b) 30° (c) 45° (d) 60°
8. The value of $\frac{2 \tan 30^\circ}{1 - \tan^2 30^\circ}$ is
(a) $\sin 60^\circ$ (b) $\cos 60^\circ$ (c) $\tan 60^\circ$ (d) $\sin 30^\circ$
9. $9 \sec^2 A - 9 \tan^2 A =$
(a) 1 (b) 9 (c) 8 (d) 0
10. $(1 + \tan A + \sec A)(1 + \cot A - \operatorname{cosec} A) =$
(a) 0 (b) 1 (c) 2 (d) -1
11. $(\sec A + \tan A)(1 - \sin A) =$
(a) $\sec A$ (b) $\sin A$ (c) $\operatorname{cosec} A$ (d) $\cos A$
12. $\frac{1 + \tan^2 A}{1 + \cot^2 A} =$
(a) $\sec^2 A$ (b) -1 (c) $\cot^2 A$ (d) $\tan^2 A$

MCQ WORKSHEET-II
CLASS X: CHAPTER - 8
INTRODUCTION TO TRIGONOMETRY

1. If $\sin 3A = \cos (A - 26^\circ)$, where $3A$ is an acute angle, find the value of A .
(a) 29° (b) 30° (c) 26° (d) 36°
2. If $\tan 2A = \cot (A - 18^\circ)$, where $2A$ is an acute angle, find the value of A .
(a) 29° (b) 30° (c) 26° (d) none of these
3. If $\sec 4A = \operatorname{cosec} (A - 20^\circ)$, where $4A$ is an acute angle, find the value of A .
(a) 22° (b) 25° (c) 26° (d) none of these
4. The value of $\tan 48^\circ \tan 23^\circ \tan 42^\circ \tan 67^\circ$ is
(a) 1 (b) 9 (c) 8 (d) 0
5. If $\triangle ABC$ is right angled at C , then the value of $\cos(A + B)$ is
(a) 0 (b) 1 (c) $\frac{1}{2}$ (d) n.d.
6. The value of the expression $\left[\frac{\sin^2 22^\circ + \sin^2 68^\circ}{\cos^2 22^\circ + \cos^2 68^\circ} + \sin^2 63^\circ + \cos 63^\circ \sin 27^\circ \right]$ is
(a) 3 (b) 0 (c) 1 (d) 2
7. If $\cos A = \frac{24}{25}$, then the value of $\sin A$ is
(a) $\frac{7}{25}$ (b) $\frac{24}{25}$ (c) 1 (d) none of these
8. If $\triangle ABC$ is right angled at B , then the value of $\cos(A + C)$ is
(a) 0 (b) 1 (c) $\frac{1}{2}$ (d) n.d.
9. If $\tan A = \frac{4}{3}$, then the value of $\cos A$ is
(a) $\frac{3}{5}$ (b) $\frac{4}{3}$ (c) 1 (d) none of these
10. If $\triangle ABC$ is right angled at C , in which $AB = 29$ units, $BC = 21$ units and $\angle ABC = \alpha$. Determine the values of $\cos^2 \alpha + \sin^2 \alpha$ is
(a) 0 (b) 1 (c) $\frac{1}{2}$ (d) n.d.
11. In a right triangle ABC , right-angled at B , if $\tan A = 1$, then the value of $2 \sin A \cos A =$
(a) 0 (b) 1 (c) $\frac{1}{2}$ (d) n.d.
12. Given $15 \cot A = 8$, then $\sin A =$
(a) $\frac{3}{5}$ (b) $\frac{4}{3}$ (c) 1 (d) none of these

MCQ WORKSHEET-III
CLASS X: CHAPTER - 8
INTRODUCTION TO TRIGONOMETRY

1. In a triangle PQR, right-angled at Q, $PR + QR = 25$ cm and $PQ = 5$ cm, then the value of $\sin P$ is
(a) $\frac{7}{25}$ (b) $\frac{24}{25}$ (c) 1 (d) none of these
 2. In a triangle PQR, right-angled at Q, $PQ = 3$ cm and $PR = 6$ cm, then $\angle QPR =$
(a) 0° (b) 30° (c) 45° (d) 60°
 3. If $\sin(A - B) = \frac{1}{2}$ and $\cos(A + B) = \frac{1}{2}$, then the value of A and B, respectively are
(a) 45° and 15° (b) 30° and 15° (c) 45° and 30° (d) none of these
 4. If $\sin(A - B) = 1$ and $\cos(A + B) = 1$, then the value of A and B, respectively are
(a) 45° and 15° (b) 30° and 15° (c) 45° and 30° (d) none of these
 5. If $\tan(A - B) = \frac{1}{\sqrt{3}}$ and $\tan(A + B) = \sqrt{3}$, then the value of A and B, respectively are
(a) 45° and 15° (b) 30° and 15° (c) 45° and 30° (d) none of these
 6. If $\cos(A - B) = \frac{\sqrt{3}}{2}$ and $\sin(A + B) = 1$, then the value of A and B, respectively are
(a) 45° and 15° (b) 30° and 15° (c) 60° and 30° (d) none of these
 7. The value of $2\cos^2 60^\circ + 3\sin^2 45^\circ - 3\sin^2 30^\circ + 2\cos^2 90^\circ$ is
(a) 1 (b) 5 (c) $5/4$ (d) none of these
 8. $\sin 2A = 2 \sin A \cos A$ is true when A =
(a) 0° (b) 30° (c) 45° (d) any angle
 9. $\sin A = \cos A$ is true when A =
(a) 0° (b) 30° (c) 45° (d) any angle
 10. If $\sin A = \frac{1}{2}$, then the value of $3\cos A - 4\cos^3 A$ is
(a) 0 (b) 1 (c) $\frac{1}{2}$ (d) n.d.
 11. If $3\cot A = 4$, then the value of $\cos^2 A - \sin^2 A$ is
(a) $\frac{3}{4}$ (b) $\frac{7}{25}$ (c) $\frac{1}{2}$ (d) $\frac{24}{25}$
 12. If $3\tan A = 4$, then the value of $\frac{3\sin A + 2\cos A}{3\sin A - 2\cos A}$ is
(a) 1 (b) $\frac{7}{25}$ (c) 3 (d) $\frac{24}{25}$
-

MCQ WORKSHEET-IV
CLASS X: CHAPTER - 8
INTRODUCTION TO TRIGONOMETRY

1. Value of θ , for $\sin 2\theta = 1$, where $0^\circ < \theta < 90^\circ$ is:
(a) 30° (b) 60° (c) 45° (d) 135° .
 2. Value of $\sec^2 26^\circ - \cot^2 64^\circ$ is:
(a) 1 (b) -1 (c) 0 (d) 2
 3. Product $\tan 1^\circ \cdot \tan 2^\circ \cdot \tan 3^\circ \dots \tan 89^\circ$ is:
(a) 1 (b) -1 (c) 0 (d) 90
 4. $\sqrt{1 + \tan^2 \theta}$ is equal to:
(a) $\cot \theta$ (b) $\cos \theta$ (c) $\operatorname{cosec} \theta$ (d) $\sec \theta$
 5. If $A + B = 90^\circ$, $\cot B = \frac{3}{4}$ then $\tan A$ is equal to;
(a) $\frac{3}{4}$ (b) $\frac{4}{3}$ (c) $\frac{1}{4}$ (d) $\frac{1}{3}$
 6. Maximum value of $\frac{1}{\operatorname{cosec} \theta}$, $0^\circ < \theta < 90^\circ$ is:
(a) 1 (b) -1 (c) 2 (d) $\frac{1}{2}$
 7. If $\cos \theta = \frac{1}{2}$, $\sin \phi = \frac{1}{2}$ then value of $\theta + \phi$ is
(a) 30° (b) 60° (c) 90° (d) 120° .
 8. If $\sin(A + B) = 1 = \cos(A - B)$ then
(a) $A = B = 90^\circ$ (b) $A = B = 0^\circ$ (c) $A = B = 45^\circ$ (d) $A = 2B$
 9. The value of $\sin 60^\circ \cos 30^\circ - \cos 60^\circ \sin 30^\circ$ is
(a) 1 (b) -1 (c) 0 (d) none of these
 10. The value of $2\sin^2 30^\circ - 3\cos^2 45^\circ + \tan^2 60^\circ + 3\sin^2 90^\circ$ is
(a) 1 (b) 5 (c) 0 (d) none of these
-

PRACTICE QUESTIONS
CLASS X: CHAPTER - 8
INTRODUCTION TO TRIGONOMETRY
TRIGONOMETRIC RATIOS

1. If $\tan \theta = \frac{1}{\sqrt{5}}$, what is the value of $\frac{\operatorname{cosec}^2 \theta - \sec^2 \theta}{\operatorname{cosec}^2 \theta + \sec^2 \theta}$?
2. If $\sin \theta = \frac{4}{5}$, find the value of $\frac{\sin \theta \tan \theta - 1}{2 \tan^2 \theta}$.
3. If $\cos A = \frac{1}{2}$, find the value of $\frac{2 \sec A}{1 + \tan^2 A}$.
4. If $\sin \theta = \frac{\sqrt{3}}{2}$, find the value of all T-ratios of θ .
5. If $\cos \theta = \frac{7}{25}$, find the value of all T-ratios of θ .
6. If $\tan \theta = \frac{15}{8}$, find the value of all T-ratios of θ .
7. If $\cot \theta = 2$, find the value of all T-ratios of θ .
8. If $\operatorname{cosec} \theta = \sqrt{10}$, find the value of all T-ratios of θ .
9. If $\tan \theta = \frac{4}{3}$, show that $(\sin \theta + \cos \theta) = \frac{7}{5}$.
10. If $\sec \theta = \frac{5}{4}$, show that $\frac{(\sin \theta - 2 \cos \theta)}{(\tan \theta - \cot \theta)} = \frac{12}{7}$.
11. If $\tan \theta = \frac{1}{\sqrt{7}}$, show that $\frac{(\operatorname{cosec}^2 \theta - \sec^2 \theta)}{(\operatorname{cosec}^2 \theta + \sec^2 \theta)} = \frac{3}{4}$.
12. If $\operatorname{cosec} \theta = 2$, show that $\left\{ \cot \theta + \frac{\sin \theta}{1 + \cos \theta} \right\} = 2$.
13. If $\sec \theta = \frac{5}{4}$, verify that $\frac{\tan \theta}{(1 + \tan^2 \theta)} = \frac{\sin \theta}{\sec \theta}$.
14. If $\cos \theta = 0.6$, show that $(5 \sin \theta - 3 \tan \theta) = 0$.
15. In a triangle ACB, right-angled at C, in which AB = 29 units, BC = 21 units and $\angle ABC = \theta$. Determine the values of (i) $\cos^2 \theta + \sin^2 \theta$ (ii) $\cos^2 \theta - \sin^2 \theta$
16. In a triangle ABC, right-angled at B, in which AB = 12 cm and BC = 5 cm. Find the value of $\cos A$, $\operatorname{cosec} A$, $\cos C$ and $\operatorname{cosec} C$.
17. In a triangle ABC, $\angle B = 90^\circ$, AB = 24 cm and BC = 7 cm. Find (i) $\sin A$, $\cos A$ (ii) $\sin C$, $\cos C$.

PRACTICE QUESTIONS
CLASS X: CHAPTER - 8
INTRODUCTION TO TRIGONOMETRY
T – RATIOS OF SOME PARTICULAR ANGLES

Evaluate each of the following:

1. $\sin 60^\circ \cos 30^\circ + \cos 60^\circ \sin 30^\circ$

2. $\cos 60^\circ \cos 30^\circ - \sin 60^\circ \sin 30^\circ$

3. $\cos 45^\circ \cos 30^\circ + \sin 45^\circ \sin 30^\circ$

4. $\sin 60^\circ \sin 45^\circ - \cos 60^\circ \cos 45^\circ$

5. $\frac{\sin 30^\circ}{\cos 45^\circ} + \frac{\cot 45^\circ}{\sec 60^\circ} - \frac{\sin 60^\circ}{\tan 45^\circ} - \frac{\cos 30^\circ}{\sin 90^\circ}$

6. $\frac{\tan^2 60^\circ + 4 \cos^2 45^\circ + 3 \operatorname{cosec}^2 60^\circ + 2 \cos^2 90^\circ}{2 \operatorname{cosec} 30^\circ + 3 \sec 60^\circ} - \frac{7}{3} \cot^2 30^\circ$

7. $4(\sin^4 30^\circ + \cos^4 60^\circ) - 3(\cos^2 45^\circ - \sin^2 90^\circ) + 5 \cos^2 90^\circ$

8. $\frac{4}{\cot^2 30^\circ} + \frac{1}{\sin^2 30^\circ} - 2 \cos^2 45^\circ - \sin^2 0^\circ$

9. $\frac{1}{\cos^2 30^\circ} + \frac{1}{\sin^3 30^\circ} - \frac{1}{2} \tan^2 45^\circ - 8 \sin^2 90^\circ$

10. $\cot^2 30^\circ - 2 \cos^2 30^\circ - \frac{3}{4} \sec^2 45^\circ + \frac{1}{4} \operatorname{cosec}^2 30^\circ$

11. $(\sin^2 30^\circ + 4 \cot^2 45^\circ - \sec^2 60^\circ)(\operatorname{cosec}^2 45^\circ \sec^2 30^\circ)$

12. In right triangle ABC, $\angle B = 90^\circ$, AB = 3cm and AC = 6cm. Find $\angle C$ and $\angle A$.

13. If $A = 30^\circ$, verify that:

(i) $\sin 2A = \frac{2 \tan A}{1 + \tan^2 A}$ (ii) $\cos 2A = \frac{1 - \tan^2 A}{1 + \tan^2 A}$ (iii) $\tan 2A = \frac{2 \tan A}{1 - \tan^2 A}$

14. If $A = 45^\circ$, verify that

(i) $\sin 2A = 2 \sin A \cos A$ (ii) $\cos 2A = 2 \cos^2 A - 1 = 1 - 2 \sin^2 A$

15. Using the formula, $\cos A = \sqrt{\frac{1 + \cos 2A}{2}}$, find the value of $\cos 30^\circ$, it being given that $\cos 60^\circ = \frac{1}{2}$

16. Using the formula, $\sin A = \sqrt{\frac{1 - \cos 2A}{2}}$, find the value of $\sin 30^\circ$, it being given that $\cos 60^\circ = \frac{1}{2}$

17. Using the formula, $\tan 2A = \frac{2 \tan A}{1 - \tan^2 A}$, find the value of $\tan 60^\circ$, it being given that

$$\tan 30^\circ = \frac{1}{\sqrt{3}}.$$

18. If $\sin(A - B) = \frac{1}{2}$ and $\cos(A + B) = \frac{1}{2}$, then find the value of A and B.

19. If $\sin(A + B) = 1$ and $\cos(A - B) = 1$, then find the value of A and B.

20. If $\tan(A - B) = \frac{1}{\sqrt{3}}$ and $\tan(A + B) = \sqrt{3}$, then find the value of A and B.

21. If $\cos(A - B) = \frac{\sqrt{3}}{2}$ and $\sin(A + B) = 1$, then find the value of A and B.

22. If A and B are acute angles such that $\tan A = \frac{1}{3}$, $\tan B = \frac{1}{2}$ and $\tan(A + B) = \frac{\tan A + \tan B}{1 - \tan A \tan B}$, show that $A + B = 45^\circ$.

23. If $A = B = 45^\circ$, verify that:

- $\sin(A + B) = \sin A \cos B + \cos A \sin B$
- $\sin(A - B) = \sin A \cos B - \cos A \sin B$
- $\cos(A + B) = \cos A \cos B - \sin A \sin B$
- $\cos(A - B) = \cos A \cos B + \sin A \sin B$
- $\tan(A + B) = \frac{\tan A + \tan B}{1 - \tan A \tan B}$
- $\tan(A - B) = \frac{\tan A - \tan B}{1 + \tan A \tan B}$

24. If $A = 60^\circ$ and $B = 30^\circ$, verify that:

- $\sin(A + B) = \sin A \cos B + \cos A \sin B$
- $\sin(A - B) = \sin A \cos B - \cos A \sin B$
- $\cos(A + B) = \cos A \cos B - \sin A \sin B$
- $\cos(A - B) = \cos A \cos B + \sin A \sin B$
- $\tan(A + B) = \frac{\tan A + \tan B}{1 - \tan A \tan B}$
- $\tan(A - B) = \frac{\tan A - \tan B}{1 + \tan A \tan B}$

25. Evaluate:

$$\frac{\sin^2 45^\circ + \frac{3}{4} \operatorname{cosec}^2 30^\circ - \cos 60^\circ + \tan^2 60^\circ}{\sin^2 30^\circ + \cos^2 60^\circ + \frac{1}{2} \sec^2 45^\circ}$$

PRACTICE QUESTIONS
CLASS X: CHAPTER - 8
INTRODUCTION TO TRIGONOMETRY
T – RATIOS OF COMPLEMENTARY ANGLES

1. Evaluate: $\cot\theta \tan(90^\circ - \theta) - \sec(90^\circ - \theta) \operatorname{cosec}\theta + (\sin^2 25^\circ + \sin^2 65^\circ) + \sqrt{3} (\tan 5^\circ \cdot \tan 15^\circ \cdot \tan 30^\circ \cdot \tan 75^\circ \cdot \tan 85^\circ)$.
2. Evaluate without using tables: $\frac{\sec\theta \operatorname{cosec}(90^\circ - \theta) - \tan\theta \cot(90^\circ - \theta) + (\sin^2 35^\circ + \sin^2 55^\circ)}{\tan 10^\circ \tan 20^\circ \tan 45^\circ \tan 70^\circ \tan 80^\circ}$
3. Evaluate: $\frac{\sec^2 54^\circ - \cot^2 36^\circ}{\operatorname{cosec}^2 57^\circ - \tan^2 33^\circ} + 2\sin^2 38^\circ \sec^2 52^\circ - \sin^2 45^\circ$.
4. Express $\sin 67^\circ + \cos 75^\circ$ in terms of trigonometric ratios of angles between 0° and 45° .
5. If $\sin 4A = \cos(A - 20^\circ)$, where A is an acute angle, find the value of A.
6. If A, B and C are the interior angles of triangle ABC, prove that $\tan\left(\frac{B+C}{2}\right) = \cot\frac{A}{2}$
7. If A, B, C are interior angles of a $\triangle ABC$, then show that $\cos\left(\frac{B+C}{2}\right) = \sin\frac{A}{2}$.
8. If A, B, C are interior angles of a $\triangle ABC$, then show that $\operatorname{cosec}\left(\frac{A+C}{2}\right) = \sec\frac{B}{2}$.
9. If A, B, C are interior angles of a $\triangle ABC$, then show that $\cot\left(\frac{B+A}{2}\right) = \tan\frac{C}{2}$.
10. Without using trigonometric tables, find the value of $\frac{\cos 70^\circ}{\sin 20^\circ} + \cos 57^\circ \operatorname{cosec} 33^\circ - 2\cos 60^\circ$.
11. If $\sec 4A = \operatorname{cosec}(A - 20^\circ)$, where 4A is an acute angle, find the value of A.
12. If $\tan 2A = \cot(A - 40^\circ)$, where 2A is an acute angle, find the value of A.
13. Evaluate $\tan 10^\circ \tan 15^\circ \tan 75^\circ \tan 80^\circ$
14. Evaluate: $\left[\frac{\sin^2 22^\circ + \sin^2 68^\circ}{\cos^2 22^\circ + \cos^2 68^\circ} + \sin^2 63^\circ + \cos 63^\circ \sin 27^\circ \right]$
15. Express $\tan 60^\circ + \cos 46^\circ$ in terms of trigonometric ratios of angles between 0° and 45° .
16. Express $\sec 51^\circ + \operatorname{cosec} 25^\circ$ in terms of trigonometric ratios of angles between 0° and 45° .
17. Express $\cot 77^\circ + \sin 54^\circ$ in terms of trigonometric ratios of angles between 0° and 45° .
18. If $\tan 3A = \cot(3A - 60^\circ)$, where 3A is an acute angle, find the value of A.
19. If $\sin 2A = \cos(A + 36^\circ)$, where 2A is an acute angle, find the value of A.
20. If $\operatorname{cosec} A = \sec(A - 10^\circ)$, where A is an acute angle, find the value of A.

21. If $\sin 5\theta = \cos 4\theta$, where 5θ and 4θ are acute angles, find the value of θ .

22. If $\tan 2A = \cot (A - 18^\circ)$, where $2A$ is an acute angle, find the value of A .

23. If $\tan 2\theta = \cot(\theta + 6^\circ)$, where 2θ and $\theta + 6^\circ$ are acute angles, find the value of θ .

24. Evaluate:

$$\frac{2 \sin 68^\circ}{\cos 22^\circ} - \frac{2 \cot 15^\circ}{5 \tan 75^\circ} - \frac{3 \tan 45^\circ \tan 20^\circ \tan 40^\circ \tan 50^\circ \tan 70^\circ}{5}$$

25. Evaluate:

$$\frac{\cos(90^\circ - \theta) \sec(90^\circ - \theta) \tan \theta}{\cos \theta \sin(90^\circ - \theta) \cot(90^\circ - \theta)} + \frac{\tan(90^\circ - \theta)}{\cot \theta} + 2$$

26. Evaluate:

$$\frac{\sin 18^\circ}{\cos 72^\circ} + \sqrt{3} \{ \tan 10^\circ \tan 30^\circ \tan 40^\circ \tan 50^\circ \tan 80^\circ \}$$

27. Evaluate:

$$\frac{3 \cos 55^\circ}{7 \sin 35^\circ} - \frac{4(\cos 70^\circ \operatorname{cosec} 20^\circ)}{7(\tan 5^\circ \tan 25^\circ \tan 45^\circ \tan 65^\circ \tan 85^\circ)}$$

28. Evaluate:

$$\cos(40^\circ - \theta) - \sin(50^\circ + \theta) + \frac{\cos^2 40^\circ + \cos^2 50^\circ}{\sin^2 40^\circ + \sin^2 50^\circ}$$

29. If $A + B = 90^\circ$, prove that $\sqrt{\frac{\tan A \tan B + \tan A \cot B}{\sin A \sec B} - \frac{\sin^2 B}{\cos^2 A}} = \tan A$

30. If $\cos 2\theta = \sin 4\theta$, where 2θ and 4θ are acute angles, find the value of θ .

.....

PRACTICE QUESTIONS
CLASS X: CHAPTER - 8
INTRODUCTION TO TRIGONOMETRY
TRIGONOMETRIC IDENTITIES

1. Prove that $\frac{\cos \theta}{1 - \tan \theta} + \frac{\sin \theta}{1 - \cot \theta} = \sin \theta + \cos \theta$.
2. Prove that $\frac{1}{2} \left\{ \frac{\sin \theta}{1 + \cos \theta} + \frac{1 + \cos \theta}{\sin \theta} \right\} = \frac{1}{\sin \theta}$.
3. Prove that: $\frac{\tan^3 \alpha}{1 + \tan^2 \alpha} + \frac{\cot^3 \alpha}{1 + \cot^2 \alpha} = \sec \alpha \operatorname{cosec} \alpha - 2 \sin \alpha \cos \alpha$
4. Prove that: $\frac{\tan A}{1 - \cot A} + \frac{\cot A}{1 - \tan A} = 1 + \tan A + \cot A = 1 + \sec A \operatorname{cosec} A$.
5. Prove that: $\frac{1 + \sin A - \cos A}{1 + \sin A + \cos A} = \sqrt{\frac{1 - \cos A}{1 + \cos A}}$
6. Prove that $(\tan A + \operatorname{cosec} B)^2 - (\cot B - \sec A)^2 = 2 \tan A \cot B (\operatorname{cosec} A + \sec B)$.
7. Prove that: $\frac{\cos A}{1 + \sin A} + \frac{1 + \sin A}{\cos A} = 2 \sec A$.
8. Prove that: $\frac{\cos A - \sin A + 1}{\cos A + \sin A - 1} = \operatorname{cosec} A + \cot A$.
9. Prove that: $\frac{\sin A + \cos A}{\sin A - \cos A} + \frac{\sin A - \cos A}{\sin A + \cos A} = \frac{2}{\sin^2 A - \cos^2 A} = \frac{2}{2 \sin^2 A - 1} = \frac{2}{1 - 2 \cos^2 A}$.
10. Prove that $\frac{\sin A}{\cot A + \operatorname{cosec} A} = 2 + \frac{\sin A}{\cot A - \operatorname{cosec} A}$.
11. Prove that $\sqrt{\frac{\sec A - 1}{\sec A + 1}} + \sqrt{\frac{\sec A + 1}{\sec A - 1}} = 2 \operatorname{cosec} A$.
12. Prove that: $\frac{1}{\operatorname{cosec} A - \cot A} - \frac{1}{\sin A} = \frac{1}{\sin A} - \frac{1}{\operatorname{cosec} A + \cot A}$.
13. Prove that: $\frac{\tan \theta + \sec \theta - 1}{\tan \theta - \sec \theta + 1} = \sec \theta + \tan \theta = \frac{1 + \sin \theta}{\cos \theta}$
14. If $x = a \sin \theta + b \cos \theta$ and $y = a \cos \theta + b \sin \theta$, prove that $x^2 + y^2 = a^2 + b^2$.
15. If $\sec \theta + \tan \theta = m$, show that $\left(\frac{m^2 - 1}{m^2 + 1} \right) = \sin \theta$.

16. Prove that: $\frac{1 + \cos \theta + \sin \theta}{1 + \cos \theta - \sin \theta} = \frac{1 + \sin \theta}{\cos \theta}$.
17. Prove that $\sec^4 A(1 - \sin^4 A) - 2 \tan^2 A = 1$
18. If $\operatorname{cosec} \theta - \sin \theta = m$ and $\sec \theta - \cos \theta = n$, prove that $(m^2 n)^{2/3} + (mn^2)^{2/3} = 1$
19. If $\tan \theta + \sin \theta = m$ and $\tan \theta - \sin \theta = n$, show that $m^2 - n^2 = 4\sqrt{mn}$
20. If $a \cos \theta - b \sin \theta = c$, prove that $(a \sin \theta + b \cos \theta) = \pm \sqrt{a^2 + b^2 - c^2}$
21. If $\cos \theta + \sin \theta = \sqrt{2} \cos \theta$, prove that $\cos \theta - \sin \theta = \sqrt{2} \sin \theta$
22. If $\left(\frac{x}{a} \sin \theta - \frac{y}{b} \cos \theta\right) = 1$ and $\left(\frac{x}{a} \cos \theta + \frac{y}{b} \sin \theta\right) = 1$, prove that $\left(\frac{x^2}{a^2} + \frac{y^2}{b^2}\right) = 2$
23. If $(\tan \theta + \sin \theta) = m$ and $(\tan \theta - \sin \theta) = n$ prove that $(m^2 - n^2)^2 = 16mn$
24. If $\operatorname{cosec} \theta - \sin \theta = a^3$ and $\sec \theta - \cos \theta = b^3$, prove that $a^2 b^2 (a^2 + b^2) = 1$
25. If $a \cos^3 \theta + 3a \sin^2 \theta \cos \theta = m$ and $a \sin^3 \theta + 3a \sin \theta \cos^2 \theta = n$, prove that $(m+n)^{2/3} + (m-n)^{2/3} = 2a^{2/3}$
26. Prove that $\sqrt{\sec^2 \theta + \operatorname{cosec}^2 \theta} = \tan \theta + \cot \theta$.
27. Prove the identity: $\frac{\sin \theta - \cos \theta + 1}{\sin \theta + \cos \theta - 1} = \frac{1}{\sec \theta - \tan \theta}$.
28. Prove the identity: $\sec^6 \theta = \tan^6 \theta + 3 \tan^2 \theta \cdot \sec^2 \theta + 1$.
29. Prove the identity: $(\sin A + \operatorname{cosec} A)^2 + (\cos A + \sec A)^2 = 7 + \tan^2 A + \cot^2 A$.
30. If $x \sin^3 \theta + y \cos^3 \theta = \sin \theta \cos \theta$ and $x \sin \theta = y \cos \theta$, prove that $x^2 + y^2 = 1$.
31. If $\sec \theta = x + \frac{1}{4x}$, Prove that $\sec \theta + \tan \theta = 2x$ or $\frac{1}{2x}$.
32. Prove that $\left(1 + \frac{1}{\tan^2 A}\right) \left(1 + \frac{1}{\cot^2 A}\right) = \frac{1}{\sin^2 A - \sin^4 A}$.
33. If $\cot \theta + \tan \theta = x$ and $\sec \theta - \cos \theta = y$, prove that $(x^2 y)^{2/3} - (xy^2)^{2/3} = 1$.
34. If $\frac{\cos \alpha}{\cos \beta} = m$ and $\frac{\cos \alpha}{\sin \beta} = n$, show that $(m^2 + n^2) \cos^2 \beta = n^2$.
35. If $\operatorname{cosec} \theta - \sin \theta = a$ and $\sec \theta - \cos \theta = b$, prove that $a^2 b^2 (a^2 + b^2 + 3) = 1$

36. If $x = r\sin A\cos C$, $y = r\sin A\sin C$ and $z = r\cos A$, prove that $r^2 = x^2 + y^2 + z^2$.

37. If $\tan A = n \tan B$ and $\sin A = m\sin B$, prove that $\cos^2 A = \frac{m^2 - 1}{n^2 - 1}$.

38. If $\sin\theta + \sin^2\theta = 1$, find the value of $\cos^{12}\theta + 3\cos^{10}\theta + 3\cos^8\theta + \cos^6\theta + 2\cos^4\theta + 2\cos^2\theta - 2$.

39. Prove that: $(1 - \sin\theta + \cos\theta)^2 = 2(1 + \cos\theta)(1 - \sin\theta)$

40. If $\sin\theta + \sin^2\theta = 1$, prove that $\cos^2\theta + \cos^4\theta = 1$.

41. If $a\sec\theta + b\tan\theta + c = 0$ and $p\sec\theta + q\tan\theta + r = 0$, prove that $(br - qc)^2 - (pc - ar)^2 = (aq - bp)^2$.

42. If $\sin\theta + \sin^2\theta + \sin^3\theta = 1$, then prove that $\cos^6\theta - 4\cos^4\theta + 8\cos^2\theta = 4$.

43. If $\tan^2\theta = 1 - a^2$, prove that $\sec\theta + \tan^3\theta\operatorname{cosec}\theta = (2 - a^2)^{3/2}$.

44. If $x = a\sec\theta + b\tan\theta$ and $y = a\tan\theta + b\sec\theta$, prove that $x^2 - y^2 = a^2 - b^2$.

45. If $3\sin\theta + 5\cos\theta = 5$, prove that $5\sin\theta - 3\cos\theta = \pm 3$.

.....

CLASS X : CHAPTER - 9
SOME APPLICATIONS TO TRIGONOMETRY

IMPORTANT FORMULAS & CONCEPTS

ANGLE OF ELEVATION

In the below figure, the line AC drawn from the eye of the student to the top of the minar is called the *line of sight*. The student is looking at the top of the minar. The angle BAC, so formed by the line of sight with the horizontal, is called the *angle of elevation* of the top of the minar from the eye of the student. Thus, the **line of sight** is the line drawn from the eye of an observer to the point in the object viewed by the observer.

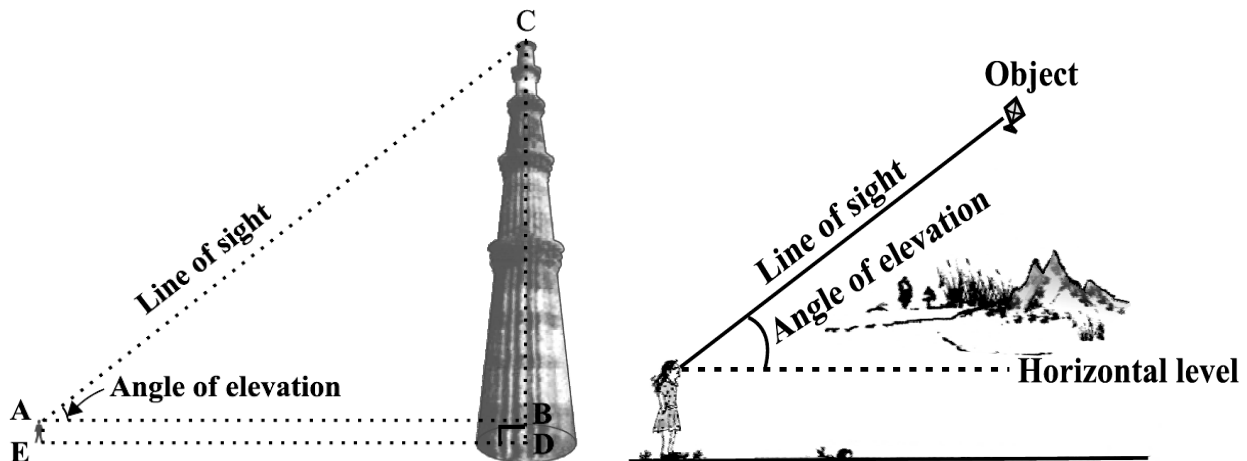

The **angle of elevation** of the point viewed is the angle formed by the line of sight with the horizontal when the point being viewed is above the horizontal level, i.e., the case when we raise our head to look at the object

ANGLE OF DEPRESSION

In the below figure, the girl sitting on the balcony is *looking down* at a flower pot placed on a stair of the temple. In this case, the line of sight is *below* the horizontal level. The angle so formed by the line of sight with the horizontal is called the *angle of depression*. Thus, the **angle of depression** of a point on the object being viewed is the angle formed by the line of sight with the horizontal when the point is below the horizontal level, i.e., the case when we lower our head to look at the point being viewed

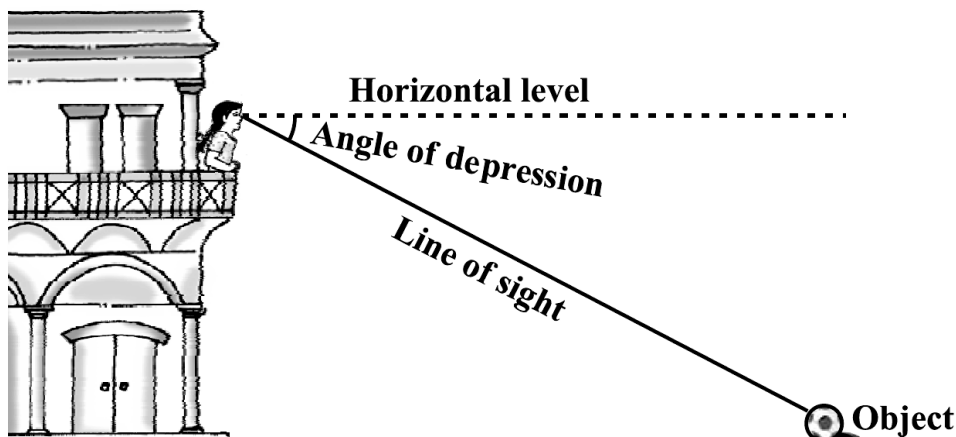

Trigonometric Ratios (T - Ratios) of an acute angle of a right triangle

In XOY-plane, let a revolving line OP starting from OX, trace out $\angle XOP = \theta$. From P (x, y) draw $PM \perp$ to OX.

In right angled triangle OMP. OM = x (Adjacent side); PM = y (opposite side); OP = r (hypotenuse).

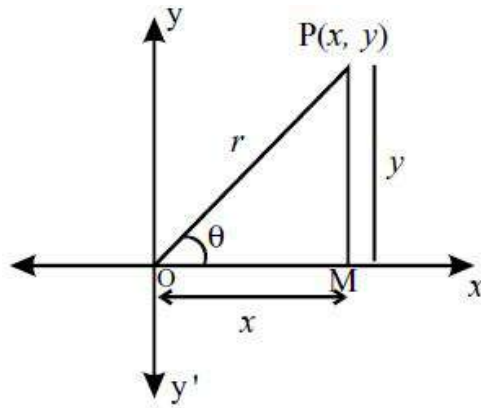

$$\sin \theta = \frac{\text{Opposite Side}}{\text{Hypotenuse}} = \frac{y}{r}, \quad \cos \theta = \frac{\text{Adjacent Side}}{\text{Hypotenuse}} = \frac{x}{r}, \quad \tan \theta = \frac{\text{Opposite Side}}{\text{Adjacent Side}} = \frac{y}{x}$$

$$\operatorname{cosec} \theta = \frac{\text{Hypotenuse}}{\text{Opposite Side}} = \frac{r}{y}, \quad \sec \theta = \frac{\text{Hypotenuse}}{\text{Adjacent Side}} = \frac{r}{x}, \quad \cot \theta = \frac{\text{Adjacent Side}}{\text{Opposite Side}} = \frac{x}{y}$$

Reciprocal Relations

$$\operatorname{cosec} \theta = \frac{1}{\sin \theta}, \quad \sec \theta = \frac{1}{\cos \theta} \quad \text{and} \quad \cot \theta = \frac{1}{\tan \theta}$$

Quotient Relations

$$\tan \theta = \frac{\sin \theta}{\cos \theta} \quad \text{and} \quad \cot \theta = \frac{\cos \theta}{\sin \theta}$$

Trigonometric ratios of Complementary angles.

$$\begin{aligned} \sin(90 - \theta) &= \cos \theta & \cos(90 - \theta) &= \sin \theta \\ \tan(90 - \theta) &= \cot \theta & \cot(90 - \theta) &= \tan \theta \\ \sec(90 - \theta) &= \operatorname{cosec} \theta & \operatorname{cosec}(90 - \theta) &= \sec \theta. \end{aligned}$$

Trigonometric ratios for angle of measure.

$0^\circ, 30^\circ, 45^\circ, 60^\circ$ and 90° in tabular form.

$\angle A$	0°	30°	45°	60°	90°
sinA	0	$\frac{1}{2}$	$\frac{1}{\sqrt{2}}$	$\frac{\sqrt{3}}{2}$	1
cosA	1	$\frac{\sqrt{3}}{2}$	$\frac{1}{\sqrt{2}}$	$\frac{1}{2}$	0
tanA	0	$\frac{1}{\sqrt{3}}$	1	$\sqrt{3}$	Not defined
cosecA	Not defined	2	$\sqrt{2}$	$\frac{2}{\sqrt{3}}$	1
secA	1	$\frac{2}{\sqrt{3}}$	$\sqrt{2}$	2	Not defined
cotA	Not defined	$\sqrt{3}$	1	$\frac{1}{\sqrt{3}}$	0

MCQ WORKSHEET-I
CLASS X: CHAPTER – 9
SOME APPLICATIONS TO TRIGONOMETRY

- The angle of elevation of the top of a tower from a point on the ground, which is 20m away from the foot of the tower is 60° . Find the height of the tower.
 (a) $10\sqrt{3}$ m (b) $30\sqrt{3}$ m (c) $20\sqrt{3}$ m (d) none of these
- The height of a tower is 10m. What is the length of its shadow when Sun's altitude is 45° ?
 (a) 10 m (b) 30 m (c) 20 m (d) none of these
- The angle of elevation of a ladder leaning against a wall is 60° and the foot of the ladder is 9.5 m away from the wall. Find the length of the ladder.
 (a) 10 m (b) 19 m (c) 20 m (d) none of these
- If the ratio of the height of a tower and the length of its shadow is $\sqrt{3} : 1$, what is the angle of elevation of the Sun?
 (a) 30° (b) 60° (c) 45° (d) none of these
- What is the angle of elevation of the Sun when the length of the shadow of a vertical pole is equal to its height?
 (a) 30° (b) 60° (c) 45° (d) none of these
- From a point on the ground, 20 m away from the foot of a vertical tower, the angle of elevation of the top of the tower is 60° , what is the height of the tower?
 (a) $10\sqrt{3}$ m (b) $30\sqrt{3}$ m (c) $20\sqrt{3}$ m (d) none of these
- If the angles of elevation of the top of a tower from two points at a distance of 4 m and 9 m from the base of the tower and in the same straight line with it are complementary, find the height of the tower.
 (a) 10 m (b) 6 m (c) 8 m (d) none of these
- In the below fig. what are the angles of depression from the observing positions D and E of the object A?
 (a) $30^\circ, 45^\circ$ (b) $60^\circ, 45^\circ$ (c) $45^\circ, 60^\circ$ (d) none of these

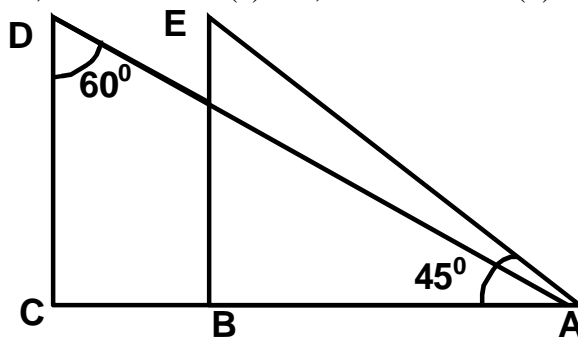

- The ratio of the length of a rod and its shadow is $1 : \sqrt{3}$. The angle of elevation of the sun is
 (a) 30° (b) 60° (c) 45° (d) none of these
- If the angle of elevation of a tower from a distance of 100m from its foot is 60° , then the height of the tower is
 (a) $100\sqrt{3}$ m (b) $\frac{200}{\sqrt{3}}$ m (c) $50\sqrt{3}$ m (d) $\frac{100}{\sqrt{3}}$ m

MCQ WORKSHEET-II
CLASS X: CHAPTER – 9
SOME APPLICATIONS TO TRIGONOMETRY

1. If the altitude of the sun is at 60° , then the height of the vertical tower that will cast a shadow of length 30m is
(a) $30\sqrt{3}$ m (b) 15 m (c) $\frac{30}{\sqrt{3}}$ m (d) $15\sqrt{2}$ m
2. A tower subtends an angle of 30° at a point on the same level as its foot. At a second point 'h' metres above the first, the depression of the foot of the tower is 60° . The height of the tower is
(a) $\frac{h}{2}$ m (b) $\frac{h}{3}$ m (c) $\sqrt{3}h$ m (d) $\frac{h}{\sqrt{3}}$ m
3. A tower is $100\sqrt{3}$ m high. Find the angle of elevation if its top from a point 100 m away from its foot.
(a) 30° (b) 60° (c) 45° (d) none of these
4. The angle of elevation of the top of a tower from a point on the ground, which is 30m away from the foot of the tower is 30° . Find the height of the tower.
(a) $10\sqrt{3}$ m (b) $30\sqrt{3}$ m (c) $20\sqrt{3}$ m (d) none of these
5. The string of a kite is 100m long and it makes an angle of 60° with the horizontal. Find the height of the kite, assuming that there is no slack in the string.
(a) $100\sqrt{3}$ m (b) $\frac{200}{\sqrt{3}}$ m (c) $50\sqrt{3}$ m (d) $\frac{100}{\sqrt{3}}$ m
6. A kite is flying at a height of 60m above the ground. The inclination of the string with the ground is 60° . Find the length of the string, assuming that there is no slack in the string.
(a) $40\sqrt{3}$ m (b) $30\sqrt{3}$ m (c) $20\sqrt{3}$ m (d) none of these
7. A circus artist is climbing a 20m long rope, which is tightly stretched and tied from the top of a vertical pole to the ground. Find the height of the pole if the angle made by the rope with the ground level is 30° .
(a) 10 m (b) 30 m (c) 20 m (d) none of these
8. A tower is 50m high, Its shadow is 'x' metres shorter when the sun's altitude is 45° than when it is 30° . Find the value of 'x'
(a) $100\sqrt{3}$ m (b) $\frac{200}{\sqrt{3}}$ m (c) $50\sqrt{3}$ m (d) none of these
9. Find the angular elevation of the sun when the shadow of a 10m long pole is $10\sqrt{3}$ m.
(a) 30° (b) 60° (c) 45° (d) none of these
10. A vertical pole stands on the level ground. From a point on the ground 25m away from the foot of the pole, the angle of elevation of its top is found to be 60° . Find the height of the pole.
(a) $25\sqrt{3}$ m (b) $\frac{25}{\sqrt{3}}$ m (c) $50\sqrt{3}$ m (d) none of these

MCQ WORKSHEET-III
CLASS X: CHAPTER – 9
SOME APPLICATIONS TO TRIGONOMETRY

1. A kite is flying at a height of 75m above the ground. The inclination of the string with the ground is 60° . Find the length of the string, assuming that there is no slack in the string.
(a) $40\sqrt{3}$ m (b) $30\sqrt{3}$ m (c) $50\sqrt{3}$ m (d) none of these
2. The angle of elevation of the top of a tree from a point A on the ground is 60° . On walking 20m away from its base, to a point B, the angle of elevation changes to 30° . Find the height of the tree.
(a) $10\sqrt{3}$ m (b) $30\sqrt{3}$ m (c) $20\sqrt{3}$ m (d) none of these
3. A 1.5m tall boy stands at a distance of 2m from lamp post and casts a shadow of 4.5m on the ground. Find the height of the lamp post.
(a) 3 m (b) 2.5 m (c) 5 m (d) none of these
4. The height of the tower is 100m. When the angle of elevation of the sun changes from 30° to 45° , the shadow of the tower becomes 'x' meters less. The value of 'x' is
(a) $100\sqrt{3}$ m (b) 100 m (c) $100(\sqrt{3} - 1)$ m (d) $\frac{100}{\sqrt{3}}$
5. The tops of two poles of height 20m and 14m are connected by a wire. If the wire makes an angle of 30° with horizontal, then the length of the wire is
(a) 12 m (b) 10 m (c) 8 m (d) 6 m
6. If the angles of elevation of a tower from two points distant a and b ($a > b$) from its foot and in the same straight line from it are 30° and 60° , then the height of the tower is
(a) $\sqrt{a+b}$ m (b) $\sqrt{a-b}$ m (c) \sqrt{ab} m (d) $\sqrt{\frac{a}{b}}$ m
7. The angles of elevation of the top of a tower from two points at a distance of 'a' m and 'b' m from the base of the tower and in the same straight line with it are complementary, then the height of the tower is
(a) $\sqrt{a+b}$ m (b) $\sqrt{a-b}$ m (c) \sqrt{ab} m (d) $\sqrt{\frac{a}{b}}$ m
8. From the top of a cliff 25m high the angle of elevation of a tower is found to be equal to the angle of depression of the foot of the tower. The height of the tower is
(a) 25 m (b) 50 m (c) 75 m (d) 100 m
9. If the angle of elevation of a cloud from a point 200m above a lake is 30° and the angle of depression of its reflection in the lake is 60° , then the height of the cloud above the lake is
(a) 200 m (b) 500 m (c) 30 m (d) 400 m
10. The angle of elevation of a cloud from a point 'h' meter above a lake is ' α '. The angle of depression of its reflection in the lake is 45° . The height of the cloud is
(a) $h \cdot \tan \alpha$ (b) $\frac{h(1 + \tan \alpha)}{(1 - \tan \alpha)}$ (c) $\frac{h(1 - \tan \alpha)}{(1 + \tan \alpha)}$ (d) none of these

PRACTICE QUESTIONS
CLASS X: CHAPTER – 9
SOME APPLICATIONS TO TRIGONOMETRY

1. A vertical stick 10 cm long casts a shadow 8 cm long. At the same time, a tower casts a shadow 30 m long. Determine the height of the tower.
2. An observer, 1.5 m tall, is 28.5 m away from a tower 30 m high. Find the angle of elevation of the top of the tower from his eye.
3. A person standing on the bank of a river observes that the angle subtended by a tree on the opposite bank is 60° . When he retreats 20m from the bank, he finds the angle to be 30° . Find the height of the tree and the breadth of the river.
4. A boy is standing on ground and flying a kite with 150m of string at an elevation of 30° . Another boy is standing on the roof of a 25m high building and flying a kite at an elevation of 45° . Find the length of string required by the second boy so that the two kites just meet, if both the boys are on opposite side of the kites.
5. An aeroplane flying horizontally 1000m above the ground, is observed at an angle of elevation 60° from a point on the ground. After a flight of 10 seconds, the angle of elevation at the point of observation changes to 30° . Find the speed of the plane in m/s.
6. An aeroplane when flying at a height of 4000 m from the ground passes vertically above another aeroplane at an instant when the angles of the elevation of the two planes from the same point on the ground are 60° and 45° respectively. Find the vertical distance between the aeroplanes at that instant.
7. An aeroplane at an altitude of 200 m observes the angles of depression of opposite points on the two banks of a river to be 45° and 60° . Find the width of the river.
8. The shadow of a flag staff is three times as long as the shadow of the flag staff when the sun rays meet the ground at an angle of 60° . Find the angle between the sun rays and the ground at the time of longer shadow.
9. A vertically straight tree, 15m high is broken by the wind in such a way that its top just touches the ground and makes an angle of 60° with the ground, at what height from the ground did the tree break?
10. A man in a boat rowing away from lighthouse 100 m high takes 2 minutes to change the angle of elevation of the top of lighthouse from 60° to 45° . Find the speed of the boat.
11. As observed from the top of a light house, 100m above sea level, the angle of depression of ship, sailing directly towards it, changes from 30° to 45° . Determine the distance travelled by the ship during the period of observation.
12. A man standing on the deck of ship, which is 10m above the water level, observes the angle of elevation of the top of a hill as 60° and the angle of depression of the base of the hill as 30° . Calculate the distance of the hill from the ship and the height of the hill.

13. The angles of elevation of the top of a tower from two points at a distance of 'a' m and 'b' m from the base of the tower and in the same straight line with it are complementary, then prove that the height of the tower is \sqrt{ab}
14. A tower stands vertically on the ground. From a point on the ground, which is 15 m away from the foot of the tower, the angle of elevation of the top of the tower is found to be 60° . Find the height of the tower.
15. An electrician has to repair an electric fault on a pole of height 5 m. She needs to reach a point 1.3m below the top of the pole to undertake the repair work. What should be the length of the ladder that she should use which, when inclined at an angle of 60° to the horizontal, would enable her to reach the required position? Also, how far from the foot of the pole should she place the foot of the ladder? (You may take $\sqrt{3} = 1.73$)
16. An observer 1.5 m tall is 28.5 m away from a chimney. The angle of elevation of the top of the chimney from her eyes is 45° . What is the height of the chimney?
17. From a point P on the ground the angle of elevation of the top of a 10 m tall building is 30° . A flag is hoisted at the top of the building and the angle of elevation of the top of the flagstaff from P is 45° . Find the length of the flagstaff and the distance of the building from the point P. (You may take $\sqrt{3} = 1.73$)
18. The shadow of a tower standing on a level ground is found to be 40 m longer when the Sun's altitude is 30° than when it is 60° . Find the height of the tower.
19. The angles of depression of the top and the bottom of an 8 m tall building from the top of a multi-storeyed building are 30° and 45° , respectively. Find the height of the multi-storeyed building and the distance between the two buildings.
20. From a point on a bridge across a river, the angles of depression of the banks on opposite sides of the river are 30° and 45° , respectively. If the bridge is at a height of 3 m from the banks, find the width of the river.
21. A 1.5 m tall boy is standing at some distance from a 30 m tall building. The angle of elevation from his eyes to the top of the building increases from 30° to 60° as he walks towards the building. Find the distance he walked towards the building.
22. From a point on the ground, the angles of elevation of the bottom and the top of a transmission tower fixed at the top of a 20 m high building are 45° and 60° respectively. Find the height of the tower.
23. A statue, 1.6 m tall, stands on the top of a pedestal. From a point on the ground, the angle of elevation of the top of the statue is 60° and from the same point the angle of elevation of the top of the pedestal is 45° . Find the height of the pedestal.
24. The angle of elevation of the top of a building from the foot of the tower is 30° and the angle of elevation of the top of the tower from the foot of the building is 60° . If the tower is 50 m high, find the height of the building.
25. A 1.2 m tall girl spots a balloon moving with the wind in a horizontal line at a height of 88.2 m from the ground. The angle of elevation of the balloon from the eyes of the girl at any instant is 60° . After some time, the angle of elevation reduces to 30° . Find the distance travelled by the balloon during the interval.

26. A straight highway leads to the foot of a tower. A man standing at the top of the tower observes a car at an angle of depression of 30° , which is approaching the foot of the tower with a uniform speed. Six seconds later, the angle of depression of the car is found to be 60° . Find the time taken by the car to reach the foot of the tower from this point.
27. A man on cliff observes a boat an angle of depression of 30° which is approaching the shore to the point immediately beneath the observer with a uniform speed. Six minutes later, the angle of depression of the boat is found to be 60° . Find the time taken by the boat to reach the shore.
28. The angles of elevation of the top of a tower from two points at a distance of 4 m and 9 m from the base of the tower and in the same straight line with it are complementary. Prove that the height of the tower is 6 m.
29. A tree breaks due to storm and the broken part bends so that the top of the tree touches the ground making an angle 30° with it. The distance between the foot of the tree to the point where the top touches the ground is 8 m. Find the height of the tree.
30. A tree is broken by the storm. The top of the tree touches the ground making an angle 30° and at a distance of 30 m from the root. Find the height of the tree.
31. A tree 12m high, is broken by the storm. The top of the tree touches the ground making an angle 60° . At what height from the bottom the tree is broken by the storm.
32. At a point on level ground, the angle of elevation of a vertical tower is found to be such that its tangent is $\frac{5}{12}$. In walking 192 m towards the tower, the tangent of the angle of elevation is $\frac{3}{4}$. Find the height of the tower.
33. The pilot of an aircraft flying horizontally at a speed of 1200km/hr, observes that the angle of depression of a point on the ground changes from 30° to 45° in 15 seconds. Find the height at which the aircraft is flying.
34. If the angle of elevation of the cloud from a point h m above a lake is A and the angle of depression of its reflection in the lake is B, prove that the height of the cloud is $\frac{h(\tan B + \tan A)}{(\tan B - \tan A)}$
35. The angle of elevation of cloud from a point 120m above a lake is 30° and the angle of depression of the reflection of the cloud in the lake is 60° . Find the height of the cloud.
36. The angle of elevation of cloud from a point 60m above a lake is 30° and the angle of depression of the reflection of the cloud in the lake is 60° . Find the height of the cloud.
37. The angle of elevation of a jet plane from a point A on the ground is 60° . After a flight of 15 seconds, the angle of elevation changes to 30° . If the jet plane is flying at a constant height of $1500\sqrt{3}$ m, find the speed of the jet plane.
38. The angle of elevation of a jet plane from a point A on the ground is 60° . After a flight of 30 seconds, the angle of elevation changes to 30° . If the jet plane is flying at a constant height of $3600\sqrt{3}$ m, find the speed of the jet plane.
39. There are two temples, one on each bank of river, just opposite to each other. One temple is 50m high. From the top of this temple, the angles of depression of the top and foot of the other temple are 30° and 60° respectively. Find the width of the river and the height of other temple.

40. A ladder rests against a wall at an angle α to the horizontal, its foot is pulled away from the wall through a distant a , so that it slides a distance b down the wall making an angle β with the horizontal. Show that $\frac{a}{b} = \frac{\cos \alpha - \cos \beta}{\sin \beta - \sin \alpha}$.
41. From a window, h meter above the ground of a house in a street, the angle of elevation and depression of the top and the foot of another house on the opposite side of the street are θ and ϕ respectively. Show that the height of the opposite house is $h(1 + \tan \theta \cot \phi)$.
42. From a window, 15 meters high above the ground of a house in a street, the angle of elevation and depression of the top and the foot of another house on the opposite side of the street are 30° and 45° respectively. Find the height of the opposite house.
43. Two stations due south of a leaning tower which leans towards the north are at distances a and b from its foot. If α and β are the elevations of the top of the tower from these stations, prove that its inclination θ to the horizontal is given by $\cot \theta = \frac{b \cot \alpha - a \cot \beta}{b - a}$.
44. The angle of elevation of a cliff from a fixed point is θ . After going up a distance of 'k' meters towards the top of the cliff at an angle of ϕ , it is found that the angle of elevation is α . Show that the height of the cliff is $\frac{k(\cos \phi - \sin \phi \cdot \cot \alpha)}{\cot \theta - \cot \alpha}$.
45. A round balloon of radius r subtends an angle α at the eye of the observer while the angle of elevation of its centre is β . Prove that the height of the centre of the balloon is $r \sin \beta \cdot \operatorname{cosec} \frac{\alpha}{2}$.
46. The angle of elevation of the top of a tower from a point on the same level as the foot of the tower is α . On advancing 'p' meters towards the foot of the tower the angle of elevation becomes β . Show that the height 'h' of the tower is given by $h = \left(\frac{p \tan \alpha \tan \beta}{\tan \beta - \tan \alpha} \right)$ m. Also determine the height of the tower if $p = 150$ m, $\alpha = 30^\circ$ and $\beta = 60^\circ$.
47. From the top of a light-house the angle of depression of two ships on the opposite sides of it are observed to be α and β . If the height of the light-house be 'h' meter and the line joining the ships passes through the foot of the light house, show that the distance between the ships is $h \left(\frac{\tan \alpha + \tan \beta}{\tan \alpha \cdot \tan \beta} \right)$ meters.
48. An electrician has to repair an electric fault on a pole of height 4m. She needs to reach a point 1.3m below the top of the pole to undertake the repair work. What should be the height of the ladder that she should use at an angle of 60° to the horizontal, would enable her reach the required position? Also, how far the foot of the pole should she place the foot of the ladder. (take $\sqrt{3} = 1.732$)
49. The angle of elevation of a jet fighter from a point A on the ground is 60° . After a flight of 15 sec, the angle of elevation changes to 30° . If the jet is flying at a speed of 720 km/hr, find the constant height at which the jet is flying.
50. A man on a top of a tower observes a truck at an angle of depression α where $\tan \alpha = \frac{1}{\sqrt{5}}$ and sees that it is moving towards the base of the tower. Ten minutes later, the angle of depression of the truck found to be β where $\tan \beta = \sqrt{5}$ if the truck is moving at uniform speed determine how much more time it will take to reach the base of the tower.

51. At the foot of a mountain the elevation of its summit is 45° ; after ascending 1000m towards the mountain up a slope of 30° inclination, the elevation is found to be 60° . Find the height of the mountain.
52. If the angle of elevation of cloud from a point h metres above a lake is α and the angle of depression of its reflection in the lake be β , prove that the distance of the cloud from the point of observation is $\frac{2h \sec \alpha}{\tan \beta - \tan \alpha}$.
53. A vertical tower stands on a horizontal plane and is surmounted by a vertical flag staff of height 'h'. At a point on the plane, the angles of elevation of the bottom and top of the flag staff are α and β respectively. Prove that the height of the tower is $\frac{h \tan \alpha}{\tan \beta - \tan \alpha}$.
54. A man on the top of a vertical tower observes a car moving at a uniform speed coming directly towards it. If it takes 12 minutes for the angle of depression to change from 30° to 45° , how soon after this, will the car reach the tower? Give your answer to the nearest second.
55. Two pillars of equal height and on either side of a road, which is 100m wide. The angles of depression of the top of the pillars are 60° and 30° at a point on the road between the pillars. Find the position of the point between the pillars and the height of the tower.
56. The angle of elevation of the top of a tower from a point A due north of the tower is α and from B due west of the tower is β . If $AB = d$, show that the height of the tower is $\frac{d \sin \alpha \sin \beta}{\sqrt{\sin^2 \alpha - \sin^2 \beta}}$.
57. The angle of elevation of the top of a tower from a point A due south of the tower is α and from B due east of the tower is β . If $AB = d$, show that the height of the tower is $\frac{d}{\sqrt{\cot^2 \alpha + \cot^2 \beta}}$.
58. From an aeroplane vertically above a straight horizontal road, the angles of depression of two consecutive milestones on opposite sides of the aeroplane are observed to be α and β . Show that the height in miles of aeroplane above the road is given by $\frac{\tan \alpha \tan \beta}{\tan \alpha + \tan \beta}$.
59. A tree standing on horizontal plane is leaning towards east. At two points situated at distances a and b exactly due west on it, angles of elevation of the top are respectively α and β . Prove that the height of the top from the ground is $\frac{(b-a) \tan \alpha \tan \beta}{\tan \alpha - \tan \beta}$.
60. The length of the shadow of a tower standing on level plane is found to be $2x$ metres longer when the sun's altitude is 30° than when it was 45° . Prove that the height of tower is $x(\sqrt{3} + 1)m$.

CLASS X : CHAPTER - 10
CIRCLES

IMPORTANT FORMULAS & CONCEPTS

Circle

The collection of all the points in a plane, which are at a fixed distance from a fixed point in the plane, is called a circle.

- The fixed point is called the *centre* of the circle and the fixed distance is called the *radius* of the circle. In the below figure, O is the centre and the length OP is the radius of the circle.

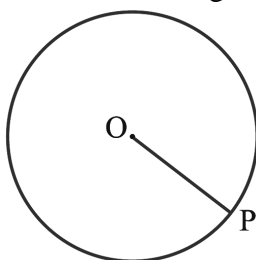

- The line segment joining the centre and any point on the circle is also called a *radius* of the circle.
- A circle divides the plane on which it lies into three parts. They are: (i) inside the circle, which is also called the *interior* of the circle; (ii) the *circle* and (iii) outside the circle, which is also called the *exterior* of the circle. The circle and its interior make up the *circular region*.
- The chord is the line segment having its two end points lying on the circumference of the circle.
- The chord, which passes through the centre of the circle, is called a *diameter* of the circle.
- A *diameter* is the longest chord and all diameters have the same length, which is equal to two times the radius.
- A piece of a circle between two points is called an *arc*.
- The longer one is called the *major arc* PQ and the shorter one is called the *minor arc* PQ.
- The length of the complete circle is called its *circumference*.
- The region between a chord and either of its arcs is called a *segment* of the circular region or simply a *segment* of the circle. There are two types of segments also, which are the *major segment* and the *minor segment*.
- The region between an arc and the two radii, joining the centre to the end points of the arc is called a *sector*. The minor arc corresponds to the *minor sector* and the major arc corresponds to the *major sector*.
- In the below figure, the region OPQ is the minor sector and remaining part of the circular region is the major sector. When two arcs are equal, that is, each is a semicircle, then both segments and both sectors become the same and each is known as a *semicircular region*.

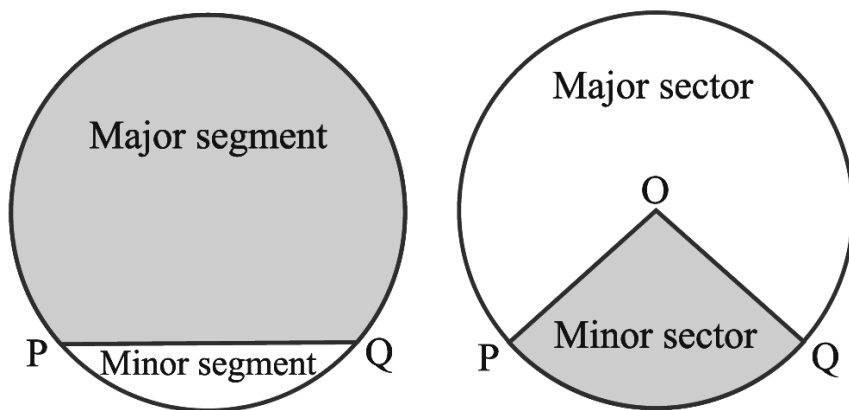

Points to Remember :

- A circle is a collection of all the points in a plane, which are equidistant from a fixed point in the plane.
- Equal chords of a circle (or of congruent circles) subtend equal angles at the centre.
- If the angles subtended by two chords of a circle (or of congruent circles) at the centre (corresponding centre) are equal, the chords are equal.
- The perpendicular from the centre of a circle to a chord bisects the chord.
- The line drawn through the centre of a circle to bisect a chord is perpendicular to the chord.
- There is one and only one circle passing through three non-collinear points.
- Equal chords of a circle (or of congruent circles) are equidistant from the centre (or corresponding centres).
- Chords equidistant from the centre (or corresponding centres) of a circle (or of congruent circles) are equal.
- If two arcs of a circle are congruent, then their corresponding chords are equal and conversely, if two chords of a circle are equal, then their corresponding arcs (minor, major) are congruent.
- Congruent arcs of a circle subtend equal angles at the centre.
- The angle subtended by an arc at the centre is double the angle subtended by it at any point on the remaining part of the circle.
- Angles in the same segment of a circle are equal.\
- Angle in a semicircle is a right angle.
- If a line segment joining two points subtends equal angles at two other points lying on the same side of the line containing the line segment, the four points lie on a circle.
- The sum of either pair of opposite angles of a cyclic quadrilateral is 180° .
- If the sum of a pair of opposite angles of a quadrilateral is 180° , then the quadrilateral is cyclic.

Secant to a Circle

A secant to a circle is a line that intersects the circle at exactly two points.

Tangent to a Circle

A tangent to a circle is a line that intersects the circle at only one point.

Given two circles, there are lines that are tangents to both of them at the same time.

☞ If the circles are separate (do not intersect), there are four possible common tangents:

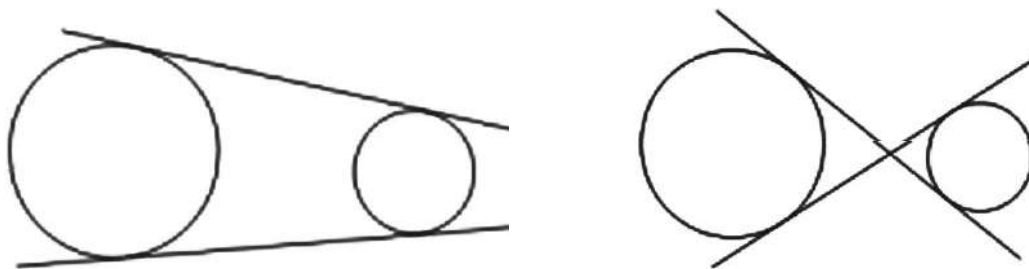

☞ If the two circles touch at just one point, there are three possible tangent lines that are common to both:

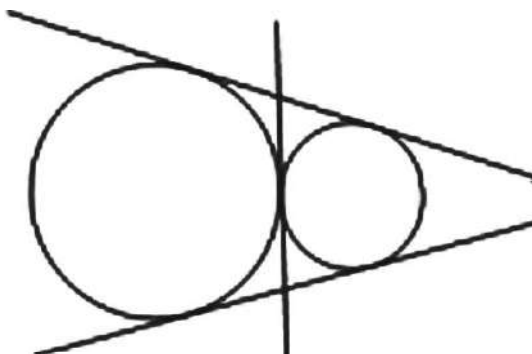

☞ If the two circles touch at just one point, with one inside the other, there is just one line that is a tangent to both:

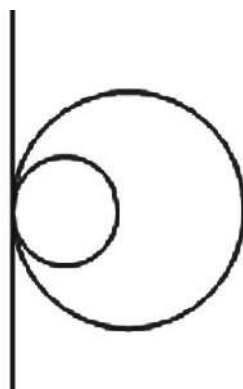

☞ If the circles overlap - i.e. intersect at two points, there are two tangents that are common to both:

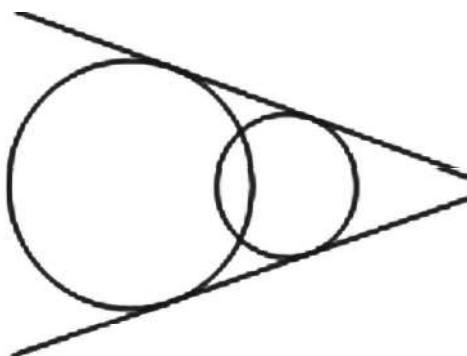

☞ If the circles lie one inside the other, there are no tangents that are common to both. A tangent to the inner circle would be a secant of the outer circle.

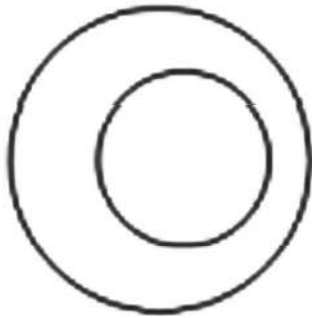

- ☞ The tangent to a circle is perpendicular to the radius through the point of contact.
 - ☞ *The lengths of tangents drawn from an external point to a circle are equal.*
 - ☞ The centre lies on the bisector of the angle between the two tangents.
 - ☞ “If a line in the plane of a circle is perpendicular to the radius at its endpoint on the circle, then the line is tangent to the circle”.
-

MCQ WORKSHEET-I
CLASS X: CHAPTER – 10
CIRCLES

- Find the length of tangent drawn to a circle with radius 7 cm from a point 25 cm away from the centre.
 (a) 24 cm (b) 27 cm (c) 26 cm (d) 25 cm
- A point P is 26 cm away from the centre of a circle and the length of the tangent drawn from P to the circle is 24 cm. Find the radius of the circle.
 (a) 11 cm (b) 10 cm (c) 16 cm (d) 15 cm
- From an external point P, tangents PA and PB are drawn to a circle with centre O. If CD is the tangent to the circle at a point E and PA = 14 cm, find the perimeter of the ΔPCD .
 (a) 28 cm (b) 27 cm (c) 26 cm (d) 25 cm

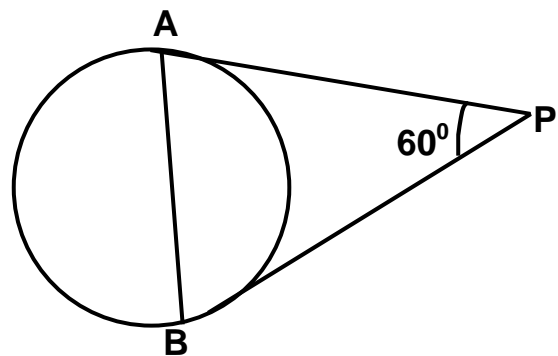
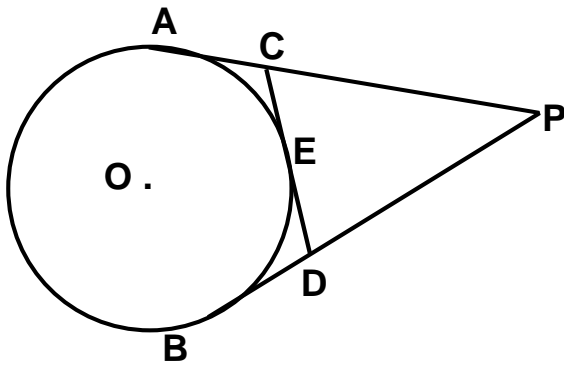

- In the above sided figure, PA and PB are tangents such that PA = 9cm and $\angle APB = 60^\circ$. Find the length of the chord AB.
 (a) 4 cm (b) 7 cm (c) 6 cm (d) 9 cm
- In the below figure the circle touches all the sides of a quadrilateral ABCD whose three sides are AB = 6 cm, BC = 7 cm, CD = 4 cm. Find AD.
 (a) 4 cm (b) 3 cm (c) 6 cm (d) 9 cm

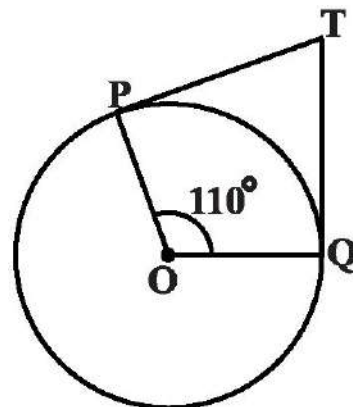
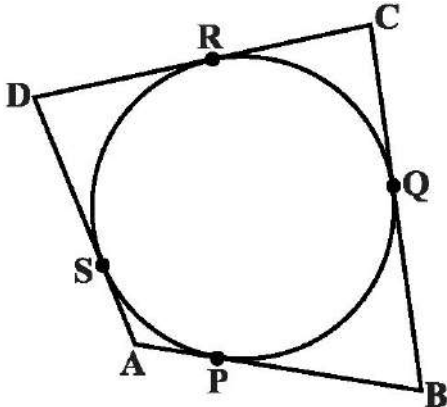

- In the above sided Fig., if TP and TQ are the two tangents to a circle with centre O so that $\angle POQ = 110^\circ$, then $\angle PTQ$ is equal to
 (a) 60° (b) 70° (c) 80° (d) 90°
- If tangents PA and PB from a point P to a circle with centre O are inclined to each other at angle of 80° , then $\angle POA$ is equal to
 (a) 60° (b) 70° (c) 80° (d) 50°

8. The length of a tangent from a point A at distance 5 cm from the centre of the circle is 4 cm. Find the radius of the circle.
 (a) 4 cm (b) 3 cm (c) 6 cm (d) 5 cm
9. From a point P, 10 cm away from the centre of a circle, a tangent PT of length 8 cm is drawn. Find the radius of the circle.
 (a) 4 cm (b) 7 cm (c) 6 cm (d) 5 cm
10. PT is tangent to a circle with centre O, $OT = 56$ cm, $TP = 90$ cm, find OP
 (a) 104 cm (b) 107 cm (c) 106 cm (d) 105 cm
11. TP and TQ are the two tangents to a circle with center O so that angle $\angle POQ = 130^\circ$. Find $\angle PTQ$.
 (a) 50° (b) 70° (c) 80° (d) none of these
12. From a point Q, the length of the tangent to a circle is 40 cm and the distance of Q from the centre is 41 cm. Find the radius of the circle.
 (a) 4 cm (b) 3 cm (c) 6 cm (d) 9 cm
13. The common point of a tangent to a circle with the circle is called _____
 (a) centre (b) point of contact (c) end point (d) none of these.
14. PQ is a chord of length 8 cm of a circle of radius 5 cm. The tangents at P and Q intersect at a point T (see below figure). Find the length TP.
 (a) $\frac{20}{3}$ cm (b) $\frac{10}{3}$ cm (c) $\frac{40}{3}$ cm (d) none of these

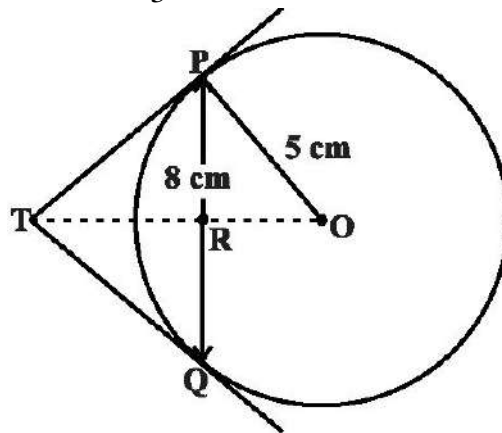

15. The lengths of tangents drawn from an external point to a circle are equal.
 (a) half (b) one third (c) one fourth (d) equal

MCQ WORKSHEET-II
CLASS X: CHAPTER – 10
CIRCLES

1. In below Fig, ABCD is a cyclic quadrilateral in which AC and BD are its diagonals. If $\angle DBC = 55^\circ$ and $\angle BAC = 45^\circ$, find $\angle BCD$.
 (a) 80° (b) 60° (c) 90° (d) none of these

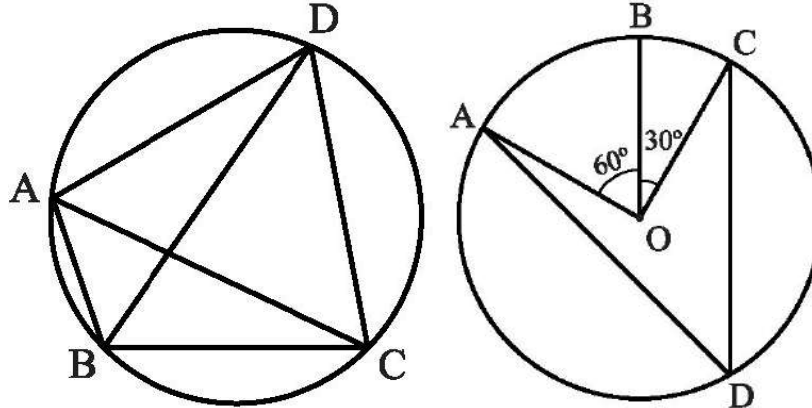

2. In above sided Fig, A, B and C are three points on a circle with centre O such that $\angle BOC = 30^\circ$ and $\angle AOB = 60^\circ$. If D is a point on the circle other than the arc ABC, find $\angle ADC$.
 (a) 45° (b) 60° (c) 90° (d) none of these

3. A chord of a circle is equal to the radius of the circle. Find the angle subtended by the chord at a point on the minor arc
 (a) 150° (b) 30° (c) 60° (d) none of these
4. A chord of a circle is equal to the radius of the circle. Find the angle subtended by the chord at a point on the major arc.
 (a) 150° (b) 30° (c) 60° (d) none of these

5. In the below Fig., $\angle ABC = 69^\circ$, $\angle ACB = 31^\circ$, find $\angle BDC$.
 (a) 80° (b) 60° (c) 90° (d) 100°

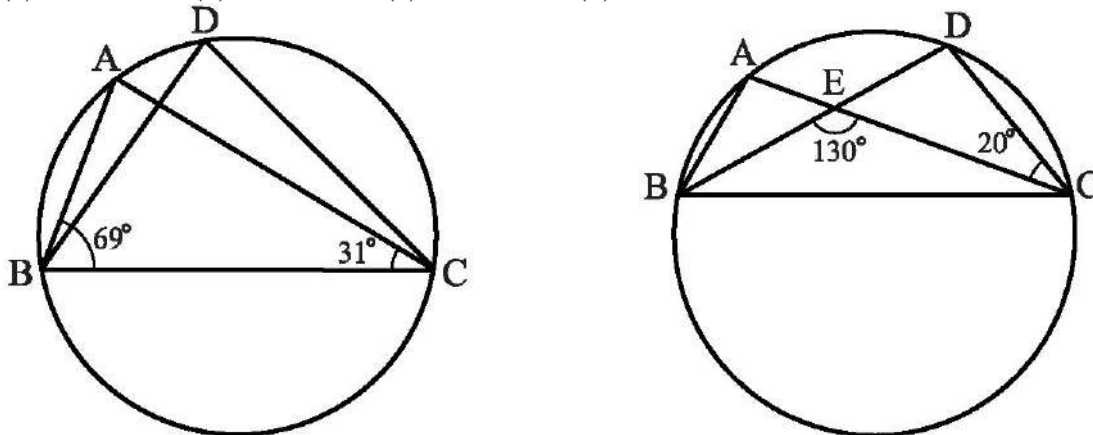

6. In the above sided Fig., A, B, C and D are four points on a circle. AC and BD intersect at a point E such that $\angle BEC = 130^\circ$ and $\angle ECD = 20^\circ$. Find $\angle BAC$.
 (a) 110° (b) 150° (c) 90° (d) 100°
7. ABCD is a cyclic quadrilateral whose diagonals intersect at a point E. If $\angle DBC = 70^\circ$, $\angle BAC$ is 30° , find $\angle BCD$.
 (a) 80° (b) 60° (c) 90° (d) 100°

8. ABCD is a cyclic quadrilateral. If $\angle BCD = 100^\circ$, $\angle ABD$ is 30° , find $\angle ACD$.
 (a) 80° (b) 60° (c) 90° (d) 70°
9. ABCD is a cyclic quadrilateral. If $\angle DBC = 80^\circ$, $\angle BAC$ is 40° , find $\angle BCD$.
 (a) 80° (b) 60° (c) 90° (d) 70°
10. ABCD is a cyclic quadrilateral in which BC is parallel to AD, $\angle ADC = 110^\circ$ and $\angle BAC = 50^\circ$.
 Find $\angle DAC$
 (a) 80° (b) 60° (c) 90° (d) 170°
11. In the below figure, $\angle POQ = 80^\circ$, find $\angle PAQ$
 (a) 80° (b) 40° (c) 100° (d) none of these

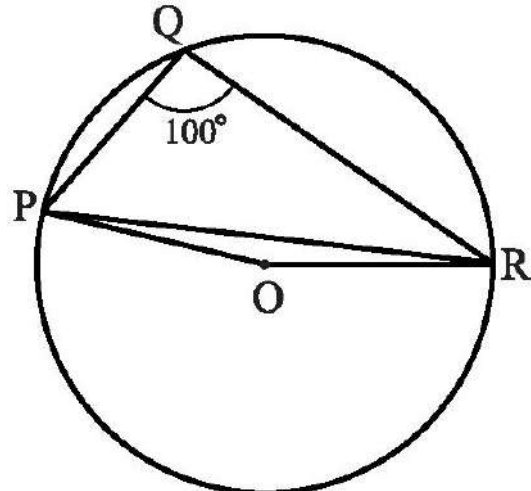
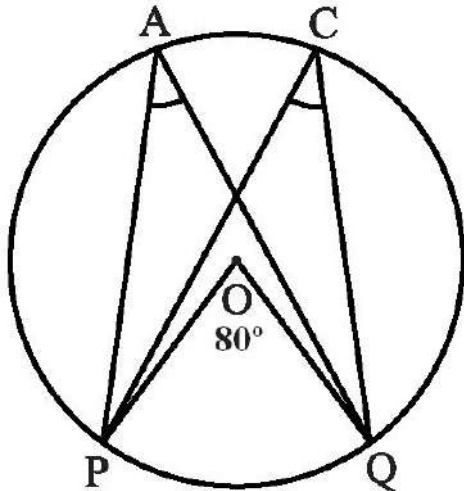

12. In the above figure, $\angle PQR = 100^\circ$, where P, Q and R are points on a circle with centre O. Find $\angle OPR$.
 (a) 80° (b) 40° (c) 10° (d) none of these

MCQ WORKSHEET-III
CLASS X: CHAPTER – 10
CIRCLES

1. Distance of chord AB from the centre is 12 cm and length of the chord is 10 cm. Then diameter of the circle is
A. 26 cm B. 13 cm C. $\sqrt{244}$ cm D. 20 cm
2. Two circles are drawn with side AB and AC of a triangle ABC as diameters. Circles intersect at a point D, Then
A. $\angle ADB$ and $\angle ADC$ are equal B. $\angle ADB$ and $\angle ADC$ are complementary
C. Points B, D, C are collinear D. none of these
3. The region between a chord and either of the arcs is called
A. an arc B. a sector C. a segment D. a semicircle
4. A circle divides the plane in which it lies, including circle in
A. 2 parts B. 3 parts C. 4 parts D. 5 parts
5. If diagonals of a cyclic quadrilateral are the diameters of a circle through the vertices of a quadrilateral, then quadrilateral is a
A. parallelogram B. square C. rectangle D. trapezium
6. Given three non collinear points, then the number of circles which can be drawn through these three points are
A. one B. zero C. two D. infinite
7. In a circle with centre O, AB and CD are two diameters perpendicular to each other. The length of chord AC is
A. 2 AB B. $\sqrt{2}$ AB C. $\frac{1}{2}$ AB D. $\frac{1}{\sqrt{2}}$ AB
8. If AB is a chord of a circle, P and Q are the two points on the circle different from A and B, then
A. $\angle APB = \angle AQB$
B. $\angle APB + \angle AQB = 180^\circ$
C. $\angle APB + \angle AQB = 90^\circ$
D. $\angle APB + \angle AQB = 180^\circ$

9. In the above figure, $\angle PQR = 90^\circ$, where P, Q and R are points on a circle with centre O. Find reflex $\angle POR$.
- (a) 180° (b) 140° (c) 45° (d) none of these

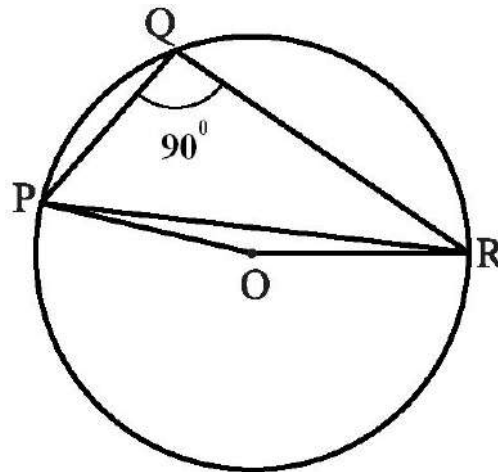

10. In below Fig, ABCD is a cyclic quadrilateral in which AC and BD are its diagonals. If $\angle DBC = 60^\circ$ and $\angle BAC = 30^\circ$, find $\angle BCD$.
- (a) 80° (b) 60° (c) 90° (d) none of these

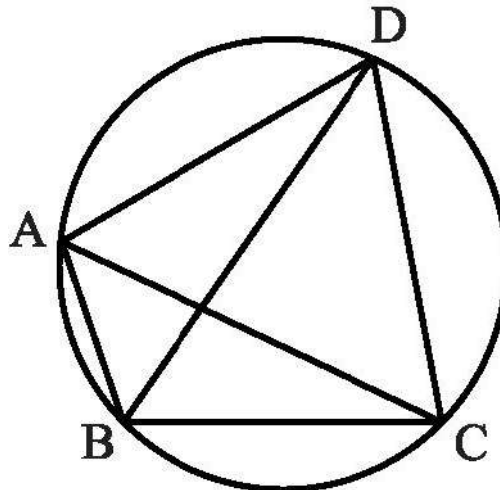

PRACTICE QUESTIONS
CLASS X: CHAPTER – 10
CIRCLES

1. Prove that “The tangent at any point of a circle is perpendicular to the radius through the point of contact”.
2. Prove that “The lengths of tangents drawn from an external point to a circle are equal.”
3. Prove that “The centre lies on the bisector of the angle between the two tangents drawn from an external point to a circle.”
4. Find the length of the tangent drawn to a circle of radius 3 cm, from a point distant 5 cm from the centre.
5. A point P is at a distance 13 cm from the centre C of a circle and PT is a tangent to the given circle. If $PT = 12$ cm, find the radius of the circle.
6. From a point Q, the length of the tangent to a circle is 24 cm and the distance of Q from the centre of the circle is 25 cm. Find the radius of the circle.
7. The tangent to a circle of radius 6 cm from an external point P, is of length 8 cm. Calculate the distance of P from the nearest point of the circle.
8. Prove that in two concentric circles, the chord of the bigger circle, which touches the smaller circle is bisected at the point of contact.
9. ΔPQR circumscribes a circle of radius r such that $\angle Q = 90^\circ$, $PQ = 3$ cm and $QR = 4$ cm. Find r .
10. Prove that the parallelogram circumscribing a circle is a rhombus.

OR

If all the sides of a parallelogram touch the circle, show that the parallelogram is a rhombus.

11. ABC is an isosceles triangle in which $AB = AC$, circumscribed about a circle. Show that BC is bisected at the point of contact.
12. In Fig., a circle is inscribed in a quadrilateral ABCD in which $\angle B = 90^\circ$. If $AD = 23$ cm, $AB = 29$ cm and $DS = 5$ cm, find the radius (r) of the circle.

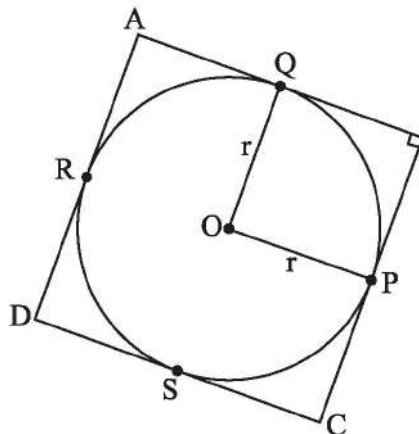

13. ABCD is a quadrilateral such that $\angle D = 90^\circ$. A circle $C(O, r)$ touches the sides AB, BC, CD and DA at P, Q, R and S respectively. If $BC = 38$ cm, $CD = 25$ cm and $BP = 27$ cm, find r .
14. An isosceles triangle ABC is inscribed in a circle. If $AB = AC = 13$ cm and $BC = 10$ cm, find the radius of the circle.
15. Two tangents TP and TQ are drawn from an external point T to a circle with centre O, as shown in fig. If they are inclined to each other at an angle of 100° then what is the value of $\angle POQ$?

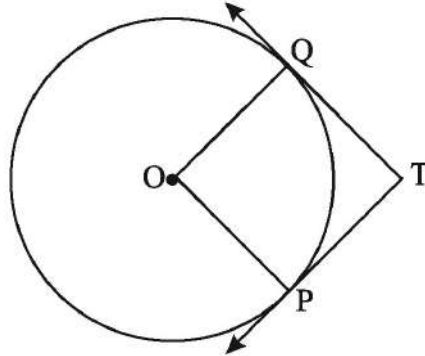

16. The incircle of $\triangle ABC$ touches the sides BC, CA and AB at D, E and F respectively. If $AB = AC$, prove that $BD = CD$.
17. XP and XQ are tangents from X to the circle with O, R is a point on the circle and a tangent through R intersects XP and XQ at A and B respectively. Prove that $XA + AR = XB + BR$.
18. A circle touches all the four sides of a quadrilateral ABCD with $AB = 6$ cm, $BC = 7$ cm and $CD = 4$ cm. Find AD.

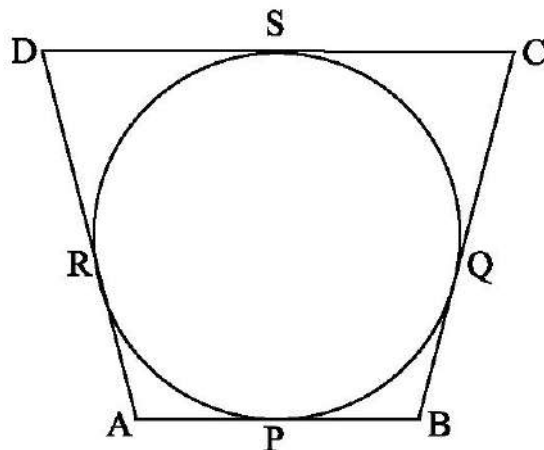

19. TP and TQ are tangents to a circle with centre O at P and Q respectively. $PQ = 8$ cm and radius of circle is 5 cm. Find TP and TQ.
20. In the below figure PT is tangent to a circle with centre O, $PT = 36$ cm, $AP = 24$ cm. Find the radius of the circle.

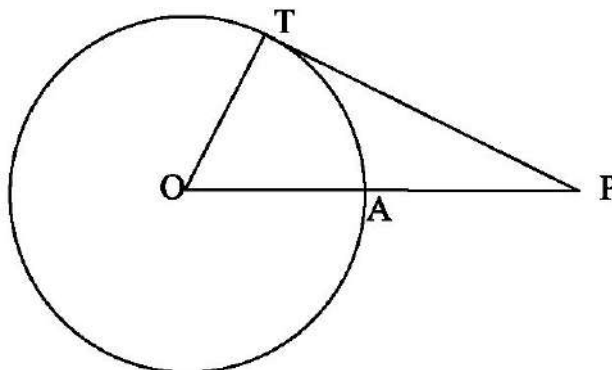

21. In the below figure, find the actual length of sides of $\triangle OTP$.

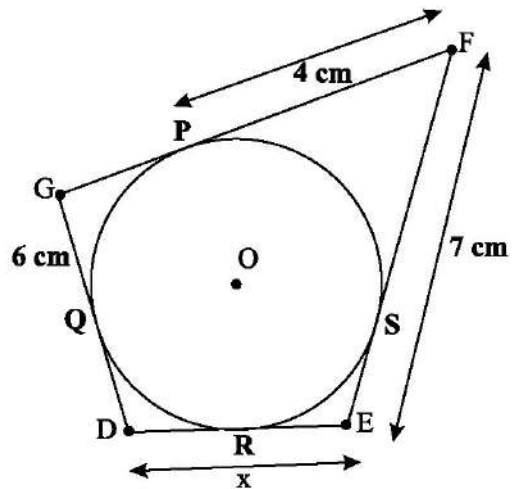
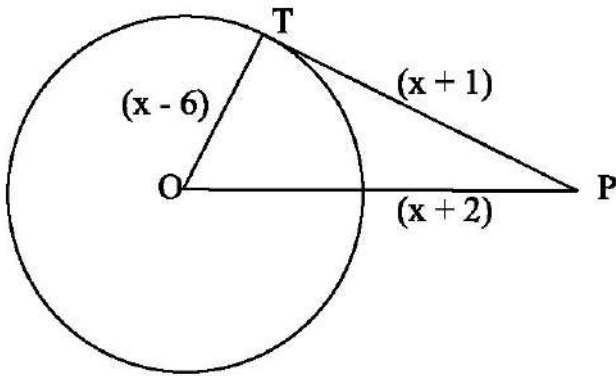

22. In the above sided figure, find the value of x .

23. Find the perimeter of DEFG.

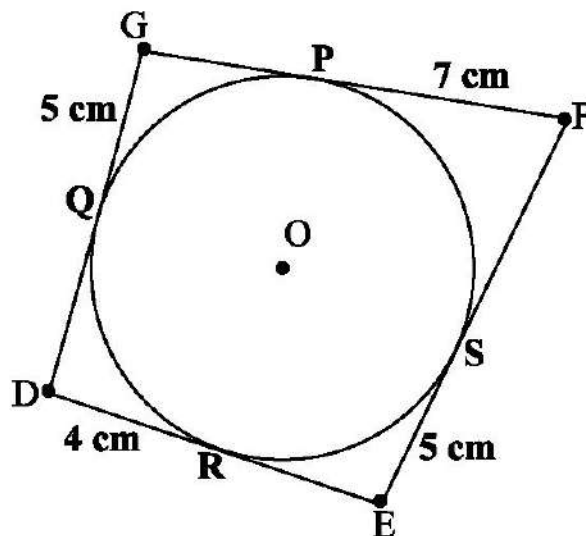

24. Two tangents TP and TQ are drawn to a circle with centre O from an external point T. Prove that $\angle PTQ = 2\angle OPQ$.

25. PQ is a chord of length 8 cm of a circle of radius 5 cm. The tangents at P and Q intersect at a point T. Find the length TP.

26. Prove that the perpendicular at the point of contact to the tangent to a circle passes through the centre.

27. The length of a tangent from a point A at distance 5 cm from the centre of the circle is 4 cm. Find the radius of the circle.

28. Two concentric circles are of radii 5 cm and 3 cm. Find the length of the chord of the larger circle which touches the smaller circle.

29. A quadrilateral ABCD is drawn to circumscribe a circle. Prove that $AB + CD = AD + BC$

30. Prove that the angle between the two tangents drawn from an external point to a circle is supplementary to the angle subtended by the line-segment joining the points of contact at the centre.

31. Prove that opposite sides of a quadrilateral circumscribing a circle subtend supplementary angles at the centre of the circle.

OR

A circle touches all the four sides a quadrilateral ABCD. Prove that the angles subtended at the centre of the circle by the opposite sides are supplementary.

32. PA and PB are the two tangents to a circle with centre O in which OP is equal to the diameter of the circle. Prove that APB is an equilateral triangle.

33. Prove that the intercept of a tangent between two parallel tangents to a circle subtends a right angle at the center of the circle.

34. If PQ and RS are two parallel tangents to a circle with centre O and another tangent X, with point of contact C intersects PQ at A and RS at B. Prove that $\angle AOB = 90^\circ$.

35. The incircle of $\triangle ABC$ touches the sides BC, CA and AB at D, E and F respectively. If $AB = AC$, prove that $BD = DC$.

36. Two tangents PA and PB are drawn to the circle with center O, such that $\angle APB = 120^\circ$. Prove that $OP = 2AP$.

37. A circle is touching the side BC of $\triangle ABC$ at P and is touching AB and AC when produced at Q and R respectively. Prove that $AQ = \frac{1}{2}$ (Perimeter of $\triangle ABC$).

38. A triangle ABC is drawn to circumscribe a circle of radius 4 cm such that the segments BD and DC into which BC is divided by the point of contact D are of lengths 8 cm and 6 cm respectively. Find the sides AB and AC.

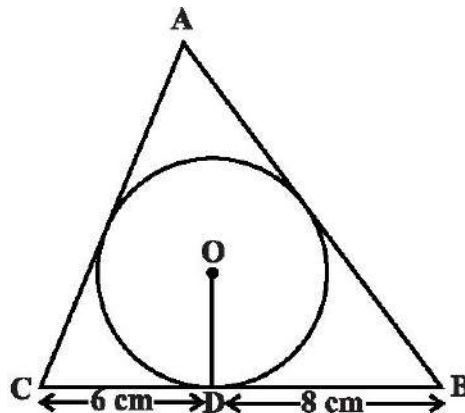

39. In figure, chords AB and CD of the circle intersect at O. $OA = 5\text{cm}$, $OB = 3\text{cm}$ and $OC = 2.5\text{cm}$. Find OD.

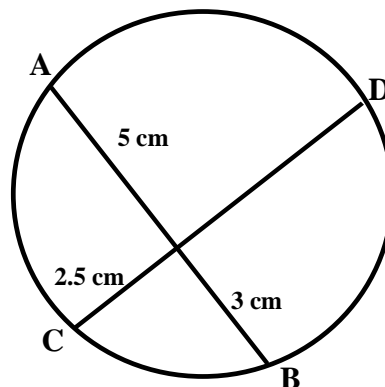

40. In figure. Chords AB and CD intersect at P. If $AB = 5\text{cm}$, $PB = 3\text{cm}$ and $PD = 4\text{cm}$. Find the length of CD.

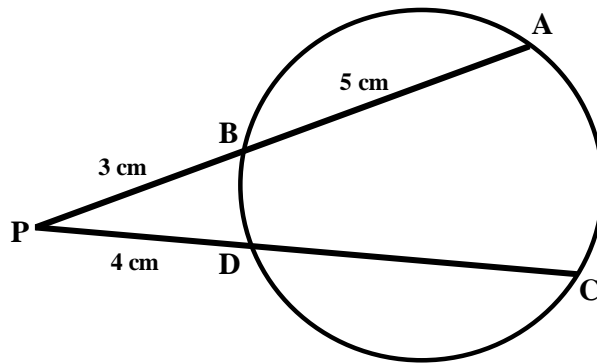

41. In the figure, ABC is an isosceles triangle in which $AB = AC$. A circle through B touches the side AC at D and intersect the side AB at P. If D is the midpoint of side AC, Then $AB = 4AP$.

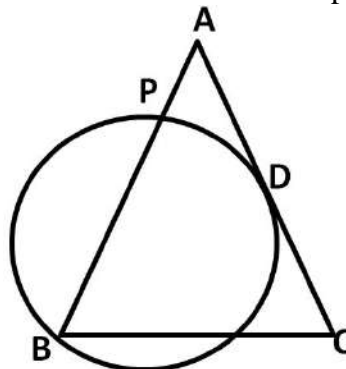

42. In the figure. Find the value of AB Where $PT = 5\text{cm}$ and $PA = 4\text{cm}$.

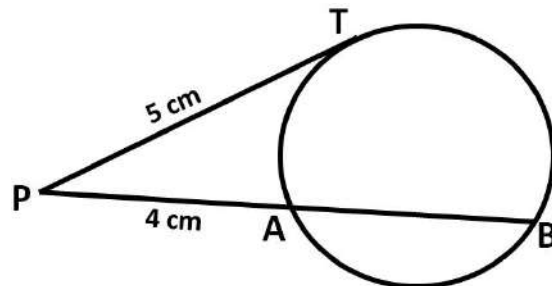

43. In the given figure, a circle touches all the four sides of a quadrilateral ABCD whose sides are $AB = 6\text{cm}$, $BC = 7\text{cm}$ and $CD = 4\text{cm}$. Find AD.

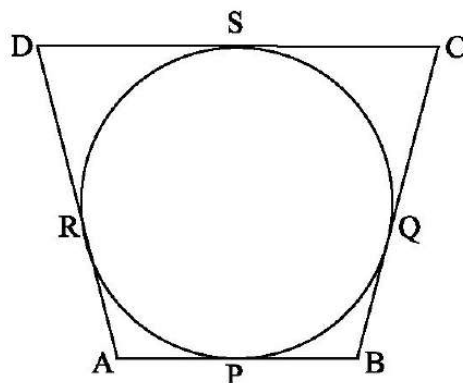

44. Prove that “If a line touches a circle and from the point of contact a chord is drawn, the angle which this chord makes with the given line are equal respectively to the angles formed in the corresponding alternate segments.”
45. Prove that “If a line is drawn through an end point of a chord of a circle so that the angle formed by it with the chord is equal to the angle subtend by chord in the alternate segment, then the line is a tangent to the circle.”

46. In figure. l and m are two parallel tangents at A and B . The tangent at C makes an intercept DE between the tangent l and m . Prove that $\angle DFE = 90^\circ$

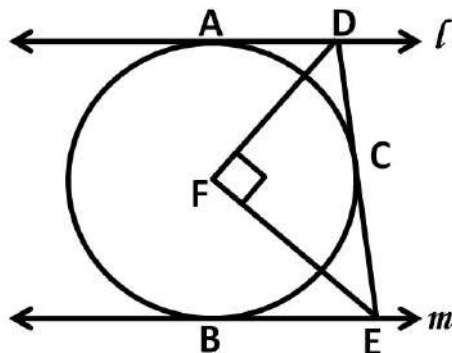

47. In figure, a circle is inscribed in a $\triangle ABC$ having sides $AB = 12$ cm, $BC = 8$ cm and $AC = 10$ cm. Find AD , BE and CF .

OR

A circle is inscribed in a $\triangle ABC$ having sides 8 cm, 10 cm and 12 cm as shown in fig. Find AD , BE and CF .

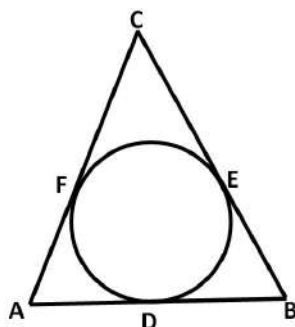

48. If PA and PB are two tangents drawn from a point P to a circle with centre O touching it at A and B , prove that OP is the perpendicular bisector of AB .
49. If $\triangle ABC$ is isosceles with $AB = AC$, Prove that the tangent at A to the circumcircle of $\triangle ABC$ is parallel to BC .
50. Two circles intersect at A and B . From a point P on one of these circles, two line segments PAC and PBD are drawn intersecting the other circles at C and D respectively. Prove that CD is parallel to the tangent at P .
51. Two circles intersect in points P and Q . A secant passing through P intersects the circles at A and B respectively. Tangents to the circles at A and B intersect at T . Prove that A , Q , T and B are concyclic.
52. In the given figure TAS is a tangent to the circle, with centre O , at the point A . If $\angle OBA = 32^\circ$, find the value of x and y .

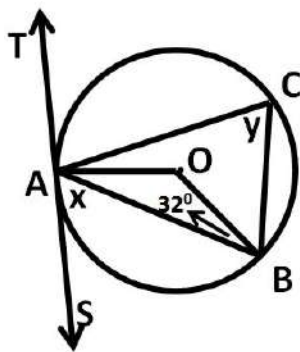

53. In the given figure. PT is a tangent and PAB is a secant to a circle. If the bisector of $\angle ATB$ intersect AB in M, Prove that: (i) $\angle PMT = \angle PTM$ (ii) $PT = PM$

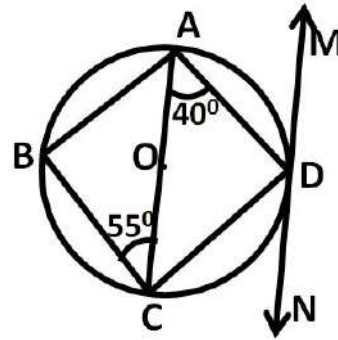
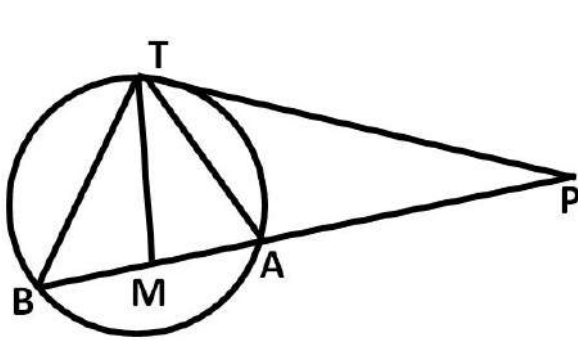

54. In the adjoining figure, ABCD is a cyclic quadrilateral. AC is a diameter of the circle. MN is tangent to the circle at D, $\angle CAD = 40^\circ$, $\angle ACB = 55^\circ$ Determine $\angle ADM$ and $\angle BAD$

55. The diagonals of a parallelogram ABCD intersect at E. Show that the circumcircle of $\triangle ADE$ and $\triangle BCE$ touch each other at E.

56. A circle is drawn with diameter AB intersecting the hypotenuse AC of right triangle ABC at the point P. Show that the tangent to the circle at P bisects the side BC.

57. In two concentric circles, prove that all chords of the outer circle which touch the inner circle are of equal length.

58. If AB, AC, PQ are tangents in below figure and $AB = 5$ cm, find the perimeter of $\triangle APQ$.

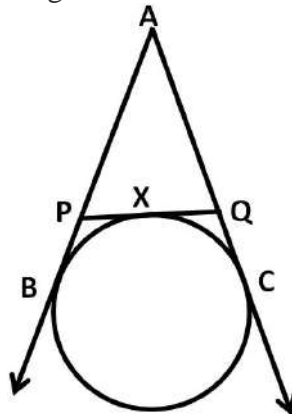

59. If PA and PB are tangents from an outside point P, such that $PA = 10$ cm and $\angle APB = 60^\circ$. Find the length of chord AB.

60. From an external point P, tangents PA and PB are drawn to a circle with centre O. If CD is the tangent to the circle at a point E and $PA = 14$ cm, find the perimeter of $\triangle PCD$.

61. Prove that the tangents at the extremities of any chord make equal angles with the chord.

62. From an external point P, two tangents PA and PB are drawn to the circle with centre O. Prove that OP is the perpendicular bisector of AB.

63. The radius of the incircle of a triangle is 4 cm and the segments into which one side divided by the point of contact are 6 cm and 8 cm. Find the other two sides of the triangle.

64. From a point P, two tangents PA and PB are drawn to a circle with centre O. If $OP =$ diameter of the circle, show that $\triangle APB$ is an equilateral triangle.

65. In fig. ABC is a right triangle right angled at B such that $BC = 6$ cm and $AB = 8$ cm. Find the radius of its incircle.

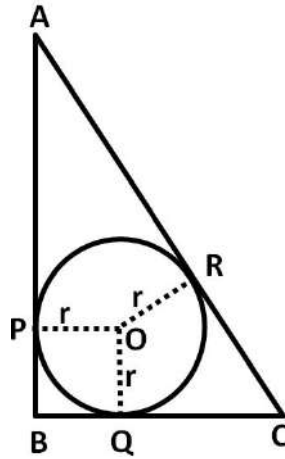

66. In the below figure, ΔABC is circumscribed, find the value of x .

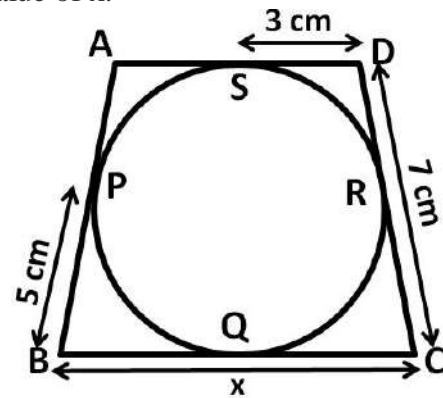
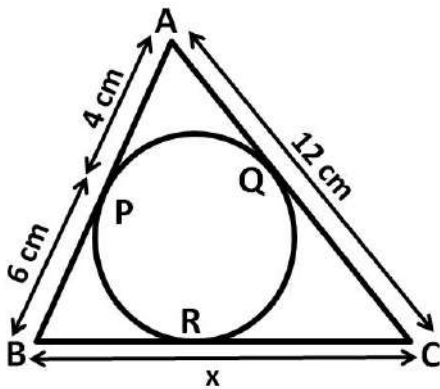

67. In the above right-sided figure, quadrilateral ABCD is circumscribed, find the value of x .

68. In the below figure, quadrilateral ABCD is circumscribed, find the perimeter of quadrilateral ABCD.

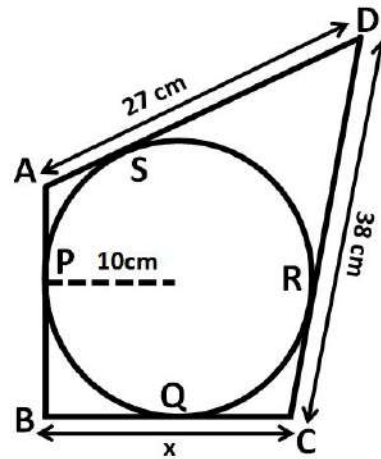
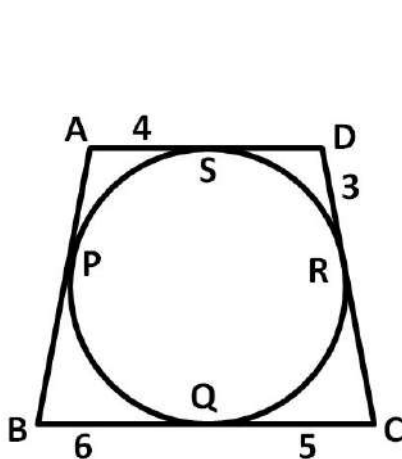

69. In the above right sided figure, quadrilateral ABCD is circumscribed and $AD \perp DC$, find the value of x if the radius of incircle is 10 cm.

70. If an isosceles triangle ABC, in which $AB = AC = 6$ cm, is inscribed in a circle of radius 9 cm, find the area of the triangle.

71. A is a point at a distance 13 cm from the centre O of a circle of radius 5 cm. AP and AQ are the tangents to the circle at P and Q. If a tangent BC is drawn at a point R lying on the minor arc PQ to intersect AP at B and AQ at C, find the perimeter of the ΔABC .

72. The tangent at a point C of a circle and a diameter AB when extended intersect at P.
If $\angle PCA = 110^\circ$, find $\angle CBA$

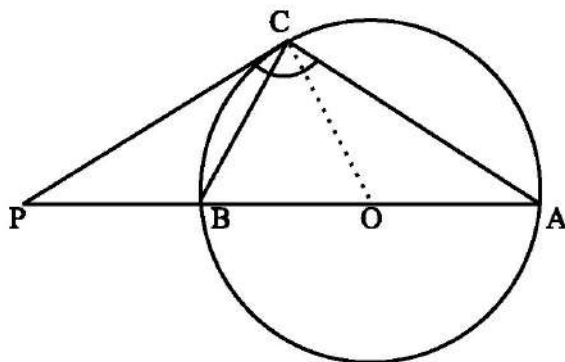

73. In a right triangle ABC in which $\angle B = 90^\circ$, a circle is drawn with AB as diameter intersecting the hypotenuse AC at P. Prove that the tangent to the circle at P bisects BC.
74. AB is a diameter and AC is a chord of a circle with centre O such that $\angle BAC = 30^\circ$. The tangent at C intersects extended AB at a point D. Prove that $BC = BD$.
75. In the below figure from an external point A, tangents AB and AC are drawn to a circle. PQ is a tangent to the circle at X. If $AC = 15$ cm, find the perimeter of the triangle APQ.

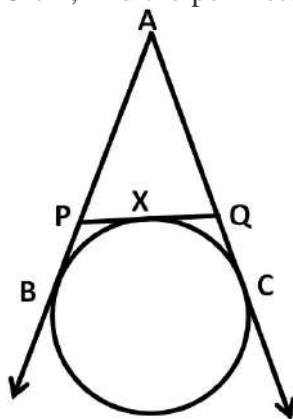

CLASS X : CHAPTER - 11
CONSTRUCTIONS

IMPORTANT CONCEPTS

To construct a triangle similar to a given triangle as per given scale factor.

Example 1 - Construct a triangle similar to a given triangle ABC with its sides equal to $\frac{3}{4}$ of the corresponding sides of the triangle ABC (i.e., of scale factor $\frac{3}{4}$).

Steps of Construction :

- ☞ Draw any ray BX making an acute angle with BC on the side opposite to the vertex A.
- ☞ Locate 4 (the greater of 3 and 4 in $\frac{3}{4}$) points B_1, B_2, B_3 and B_4 on BX so that $BB_1 = B_1B_2 = B_2B_3 = B_3B_4$.
- ☞ Join B_4C and draw a line through B_3 (the 3rd point, 3 being smaller of 3 and 4 in $\frac{3}{4}$) parallel to B_4C to intersect BC at C' .
- ☞ Draw a line through C' parallel to the line CA to intersect BA at A' (see below figure).

Then, $\Delta A'BC'$ is the required triangle.

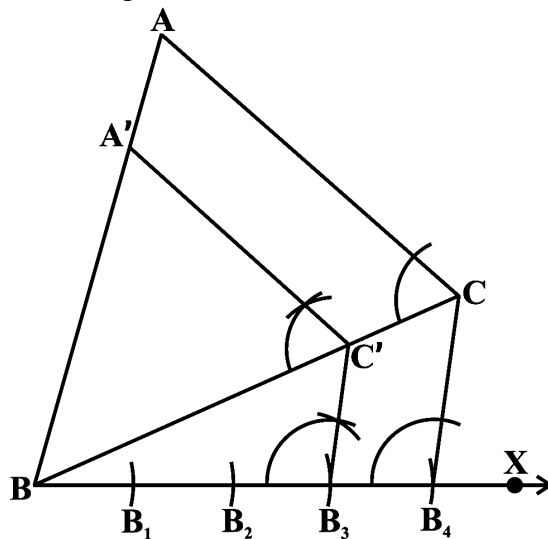

Example 2 : Construct a triangle similar to a given triangle ABC with its sides equal to $\frac{5}{3}$ of the corresponding sides of the triangle ABC (i.e., of scale factor $\frac{5}{3}$).

Steps of Construction :

- Draw any ray BX making an acute angle with BC on the side opposite to the vertex A.
- Locate 5 points (the greater of 5 and 3 in $\frac{5}{3}$) B_1, B_2, B_3, B_4 and B_5 on BX so that $BB_1 = B_1B_2 = B_2B_3 = B_3B_4 = B_4B_5$.

- Join B_3 (the 3rd point, 3 being smaller of 3 and 5 in $\frac{5}{3}$) to C and draw a line through B_5 parallel to B_3C , intersecting the extended line segment BC at C' .
- Draw a line through C' parallel to CA intersecting the extended line segment BA at A' (see the below figure).
Then $A'BC'$ is the required triangle.

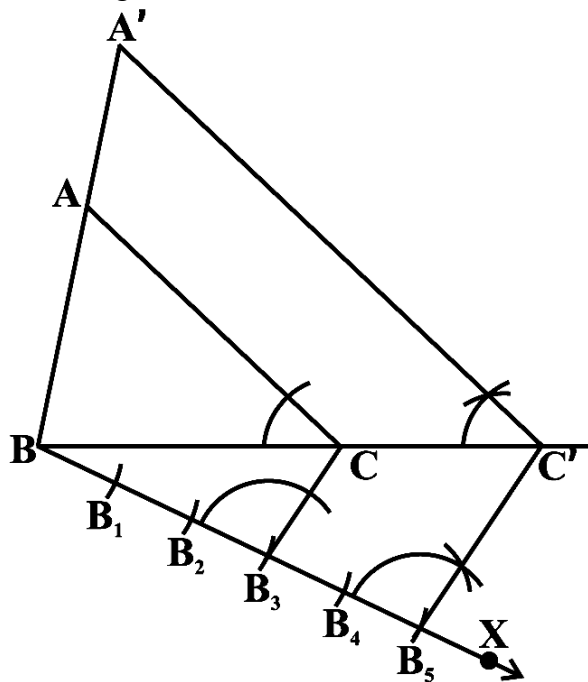

To construct the tangents to a circle from a point outside it.

Given : We are given a circle with centre 'O' and a point P outside it. We have to construct two tangents from P to the circle.

Steps of construction :

- ☞ Join PO and draw a perpendicular bisector of it. Let M be the midpoint of PO.
- ☞ Taking M as centre and PM or MO as radius, draw a circle. Let it intersect the given circle at the points A and B.
- ☞ Join PA and PB.

Then PA and PB are the required two tangents.

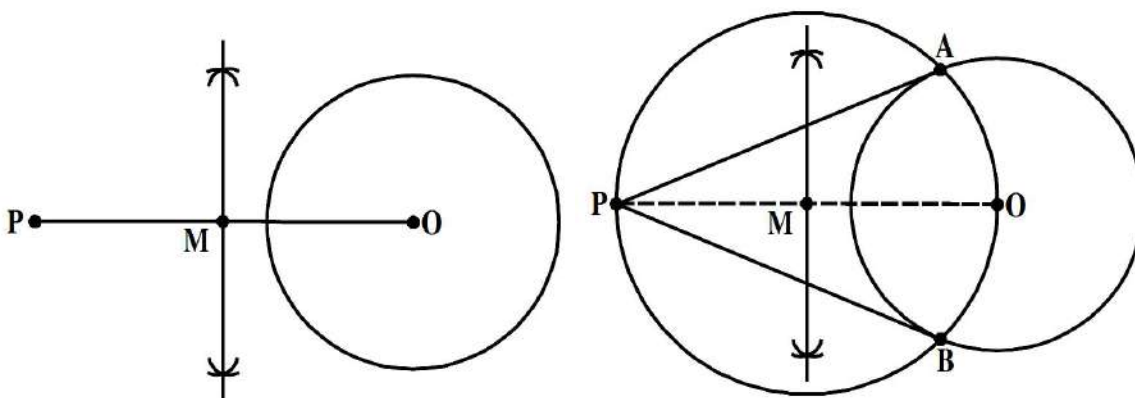

To Construct a tangent to a circle at a given point when the centre of the circle is known.

We have a circle with centre 'O' and a point P anywhere on its circumference. Then we have to construct a tangent through P.

Steps of Construction :

- ☞ Draw a circle with centre 'O' and mark a point 'P' anywhere on it. Join OP.
- ☞ Draw a perpendicular line through the point P and name it as XY, as shown in the figure.
- ☞ XY is the required tangent to the given circle passing through P.

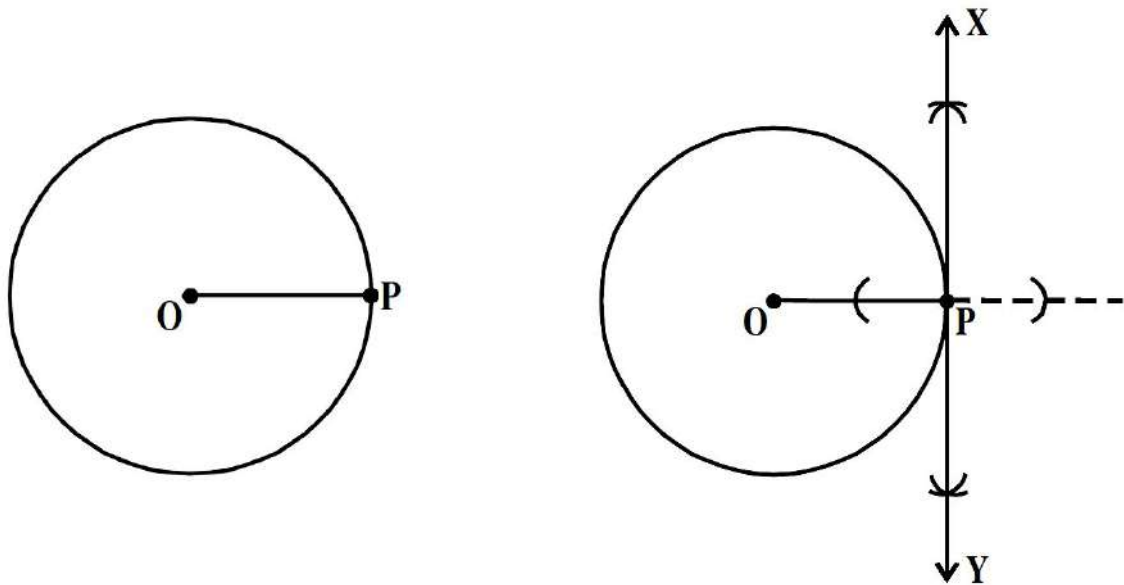

MCQ WORKSHEET-I
CLASS X: CHAPTER – 11
CONSTRUCTIONS

1. To divide a line segment AB in the ratio 3 : 7, first a ray AX is drawn so that angle BAX is an acute angle and then at equal distances point are marked on the ray AX such that the minimum number of these point is
(a) 3 (b) 10 (c) 7 (d) 12
2. To divide a line segment AB in the ratio 4 : 5, first a ray AX is drawn first such that angle BAX is an acute angle and then points A1, A2, A3, are located at equal distances on the ray AX and the point B is joined to
(a) A4 (b) A5 (c) A10 (d) A9
3. To divide a line segment AB in the ratio 4 : 5, first a ray AX is drawn first such that angle BAX is an acute angle, then draw a ray BY parallel to AX and the points A1, A2, A3, And B1, B2, B3, ... are located at equal distances on the ray AX and BY respectively, then the points joined are
(a) A5 and B6 (b) A6 and B5 (c) A4 and B5 (d) A5 and B4
4. To construct a triangle similar to a given ΔABC with its sides $\frac{2}{5}$ of the corresponding sides of ΔABC , first draw a ray BX such that angle CBX is an acute angle and X lies on the opposite side of A with respect to BC. Then, locate point A1, A2, A3,.... On BX at equal distance and next steps is to join
(a) A7 to C (b) A2 to C (c) A5 to C (d) A4 to C
5. To construct a triangle similar to a given ΔABC with its sides $\frac{2}{5}$ of the corresponding sides of ΔABC , first draw a ray BX such that angle CBX is an acute angle and X lies on the opposite side of A with respect to BC. The minimum number of points to be located at equal distances on ray BX is
(a) 3 (b) 5 (c) 8 (d) 2
6. To construct a triangle similar to a given ΔABC with its sides $\frac{4}{3}$ of the corresponding sides of ΔABC , first draw a ray BX such that angle CBX is an acute angle and X lies on the opposite side of A with respect to BC. The minimum number of points to be located at equal distances on ray BX is
(a) 3 (b) 4 (c) 7 (d) none of these
7. To draw a pair of tangents to a circle which are inclined to each other at an angle of 30° , it is required to draw tangents at end points of those two radii of the circle, the angle between them, should be
(a) 150° (b) 90° (c) 60° (d) 120°
8. To draw a pair of tangents to a circle which are inclined to each other at an angle of 60° , it is required to draw tangents at end points of those two radii of the circle, the angle between them, should be
(a) 150° (b) 90° (c) 60° (d) 120°
9. In a pair of set, squares, one if with angles are
(a) $30^\circ, 60^\circ, 90^\circ$ (b) $30^\circ, 30^\circ, 45^\circ$ (c) $75^\circ, 25^\circ, 80^\circ$ (d) $65^\circ, 15^\circ, 100^\circ$

~~10. In a pair of set, squares, the other is with angles~~

(a) $45^{\circ}, 45^{\circ}, 90^{\circ}$ (b) $30^{\circ}, 50^{\circ}, 100^{\circ}$ (c) $60^{\circ}, 60^{\circ}, 60^{\circ}$ (d) none of these

11. To draw the perpendicular bisector of line segment AB, we open the compass

(a) more than $\frac{1}{2}AB$ (b) less than $\frac{1}{2}AB$ (c) equal to $\frac{1}{2}AB$ (d) none of these

12. To construct an angle of $22\frac{1}{2}^{\circ}$, we

(a) bisect an angle of 60° (b) bisect an angle of 30°
(c) bisect an angle of 45° (d) none of these

13. To construct a triangle we must know at least its _____ parts.

(a) two (b) three (c) one (d) five

14. For which of the following condition the construction of a triangle is not possible:

(a) If two sides and angle included between them is not given
(b) If two sides and angle included between them is not given
(c) If its three sides are given
(d) If two angles and side included between them is given

15. Construction of a triangle is not possible if:

(a) $AB + BC < AC$ (b) $AB + BC = AC$ (c) both (a) and (b) (d) $AB + BC > AC$

16. With the help of ruler and compass it is not possible to construct an angle of

(a) 37.5° (b) 40.5° (c) 22.5° (d) 67.5°

17. The construction of a triangle ABC given that $BC = 3$ cm, $\angle C = 60^{\circ}$ is possible when difference of AB and AC is equal to

(a) 3.2 cm (b) 3.1 cm (c) 3 cm (d) 2.8 cm

18. The construction of a triangle ABC, given that $BC = 6$ cm, $\angle = 45^{\circ}$ is not possible when the difference of AB and AC is equal to

(a) 6.9 cm (b) 5.2 cm (c) 5.0 cm (d) 4.0 cm.

19. Construction of a triangle is not possible if:

(a) $AB - BC < AC$ (b) $AB - BC = AC$ (c) both (a) and (b) (d) $AB - BC > AC$

20. To construct an angle of 15° , we

(a) bisect an angle of 60° (b) bisect an angle of 30°
(c) bisect an angle of 45° (d) none of these

PRACTICE QUESTIONS
CLASS X: CHAPTER – 11
CONSTRUCTIONS

1. Draw two tangents to a circle of radius 3.5 cm from a point P at a distance of 5.5 cm from its centre.
2. Construct a similar ΔABC such that each of its side is $\frac{2}{3}$ of the corresponding sides of ΔABC . It is given that $AB = 5$ cm, $AC = 6$ cm and $BC = 7$ cm.
3. Draw a line segment AB of length 4.4cm. Taking A as centre, draw a circle of radius 2cm and taking B as centre, draw another circle of radius 2.2cm. Construct tangents to each circle from the centre of the other circle.
4. Draw a pair of tangents to a circle of radius 2 cm that are inclined to each other at an angle of 90° .
5. Draw a pair of tangents to a circle of radius 3 cm that are inclined to each other at an angle of 50° .
6. Construct a tangent to a circle of radius 2 cm from a point on the concentric circle of radius 2.6cm and measure its length. Also, verify the measurements by actual calculations.
7. Construct an isosceles triangle whose base is 7 cm and altitude 4 cm and then construct another similar triangle whose sides are $\frac{3}{2}$ time the corresponding sides of the isosceles triangle.
8. Construct an isosceles triangle whose base is 8 cm and altitude 4 cm and then another triangle whose sides are $1\frac{1}{2}$ times the corresponding sides of the isosceles triangle.
9. Draw a triangle ABC with side $BC = 6$ cm, $AB = 5$ cm and $\angle ABC = 60^\circ$. Then construct a triangle whose sides are $\frac{3}{4}$ of the corresponding sides of the triangle ABC.
10. Draw a triangle ABC with side $BC = 7$ cm, $\angle B = 45^\circ$, $\angle A = 105^\circ$. Then, construct a triangle whose sides are $\frac{4}{3}$ times the corresponding sides of ΔABC .
11. Draw a right triangle in which the sides (other than hypotenuse) are of lengths 4 cm and 3 cm. Then construct another triangle whose sides are $\frac{5}{3}$ times the corresponding sides of the given triangle.
12. Draw a circle with the help of a bangle. Take a point outside the circle. Construct the pair of tangents from this point to the circle.
13. Draw a circle of radius 6 cm. From a point 10 cm away from its centre, construct the pair of tangents to the circle and measure their lengths.

14. Construct a tangent to a circle of radius 4 cm from a point on the concentric circle of radius 6 cm and measure its length. Also verify the measurement by actual calculation.
15. Draw a circle of radius 3 cm. Take two points P and Q on one of its extended diameter each at a distance of 7 cm from its centre. Draw tangents to the circle from these two points P and Q.
16. Draw a pair of tangents to a circle of radius 5 cm which are inclined to each other at an angle of 60° .
17. Draw a line segment AB of length 8 cm. Taking A as centre, draw a circle of radius 4 cm and taking B as centre, draw another circle of radius 3 cm. Construct tangents to each circle from the centre of the other circle.
18. Draw a circle of radius 5cm. Take a point P on it. Without using the centre of the circle, construct a tangent at the point P. Write the steps of construction also.
19. Draw a circle of diameter 12cm. From a point P, 10cm away from its centre, construct a pair of tangent to the circle. Measure the lengths of the tangent segments.
20. Draw a circle of radius 5cm. from a point P, 7cm away from its centre, construct a pair of tangents to the circle. Measure the length of the tangent segments.
21. Draw a circle of radius 7cm. From a point P, 8cm away from its centre, Construct a pair tangents to the circle. Measure the length of the tangent segments.
22. Draw a right angled triangle ABC with $AB = 4.5\text{cm}$, $AC = 7.5\text{cm}$ and $\angle B = 90^\circ$. Construct its incircle. Write the steps of construction.
23. Construct a triangle ABC in which $BC = 13\text{cm}$, $CA = 5\text{cm}$ and $AB = 12\text{cm}$. Draw its incircle and measure its radius.
24. Construct a triangle ABC in which $AB = 3\text{cm}$, $BC = 4\text{cm}$ and $AC = 5\text{cm}$. Draw the circumcircle of triangle ABC.
25. Construct the circumcircle of an equilateral triangle with side 6cm. Write the steps of construction.



CLASS X : CHAPTER - 12
AREAS RELATED TO CIRCLES

IMPORTANT FORMULAS & CONCEPTS

Perimeter and Area of a Circle

Perimeter/circumference of a circle = $\pi \times \text{diameter}$
= $\pi \times 2r$ (where r is the radius of the circle)
= $2\pi r$

Area of a circle = πr^2 , where $\pi = \frac{22}{7}$

Areas of Sector and Segment of a Circle

Area of the sector of angle $\theta = \frac{\theta}{360^\circ} \times \pi r^2$, where r is the radius of the circle and θ the angle of the sector in degrees

length of an arc of a sector of angle $\theta = \frac{\theta}{360^\circ} \times 2\pi r$, where r is the radius of the circle and θ the angle of the sector in degrees

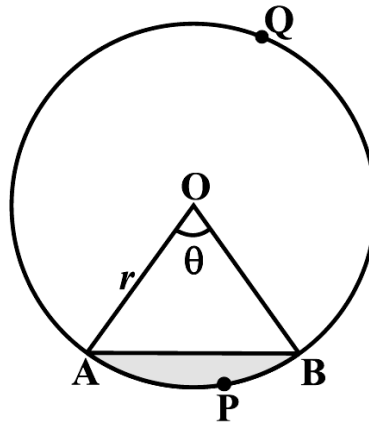

Area of the segment APB = Area of the sector OAPB – Area of Δ OAB

$$= \frac{\theta}{360^\circ} \times \pi r^2 - \text{area of } \Delta \text{ OAB}$$

☞ Area of the major sector OAQB = πr^2 – Area of the minor sector OAPB

☞ Area of major segment AQB = πr^2 – Area of the minor segment APB

☞ Area of segment of a circle = Area of the corresponding sector – Area of the corresponding triangle

MCQ WORKSHEET-I
CLASS X: CHAPTER – 12
AREAS RELATED TO CIRCLES

1. The area of a circle is $49\pi \text{ cm}^2$. Its circumference is
(a) $7\pi \text{ cm}$ (b) $14\pi \text{ cm}$ (c) $21\pi \text{ cm}$ (d) $28\pi \text{ cm}$
2. The perimeter of circular field is 242cm. The area of the field is
(a) 9317 cm^2 (b) 18634 cm^2 (c) 4658.5 cm^2 (d) none of these
3. The area of a circle is 38.5 cm^2 . Its circumference is
(a) 62 cm (b) 12.1 cm (c) 11 cm (d) 22 cm
4. The difference between the circumference and radius of a circle is 37 cm. The area of the circle is
(a) 111 cm^2 (b) 184 cm^2 (c) 154 cm^2 (d) 259 cm^2
5. The circumference of two circles are in the ratio 2 : 3. The ratio of their areas is
(a) 2 : 3 (b) 4 : 9 (c) 9 : 4 (d) none of these
6. On increasing the diameter of circle by 40%, its area will be increased by
(a) 40% (b) 80% (c) 96% (d) none of these
7. On decreasing the radius of the circle by 30%, its area is decreased by
(a) 30% (b) 60% (c) 45% (d) none of these
8. The area of the square is the same as the area of the circle. Their perimeter are in the ratio
(a) 1 : 1 (b) $\pi : 2$ (c) $2 : \pi$ (d) none of these
9. The areas of the two circles are in the ratio 4 : 9. The ratio of their circumference is
(a) 2 : 3 (b) 4 : 9 (c) 9 : 4 (d) 4 : 9
10. In making 1000 revolutions, a wheel covers 88 km. The diameter of the wheel is
(a) 14 m (b) 24 m (c) 28 m (d) 40 m
11. The diameter of a wheel is 40 cm. How many revolutions will it make in covering 176 m?
(a) 140 (b) 150 (c) 160 (d) 166
12. The radius of wheel is 0.25 m. How many revolutions will it make in covering 11 km?
(a) 2800 (b) 4000 (c) 5500 (d) 7000
13. Find the circumference of a circle of diameter 21 cm.
(a) 62 cm (b) 64 cm (c) 66 cm (d) 68 cm
14. Find the area of a circle whose circumference is 52.8 cm.
(a) 221.76 cm^2 (b) 220.76 cm^2 (c) 200.76 cm^2 (d) none of these.
15. A steel wire when bent in the form of a square, encloses an area of 121 sq. cm. The same wire is bent in the form of a circle. Find the area of the circle.
(a) 111 cm^2 (b) 184 cm^2 (c) 154 cm^2 (d) 259 cm^2

MCQ WORKSHEET-II
CLASS X: CHAPTER – 12
AREAS RELATED TO CIRCLES

1. A wire is looped in the form of a circle of radius 28 cm. It is rebent into a square form. Determine the length of the side of the square.
(a) 42 cm (b) 44 cm (c) 46 cm (d) 48 cm
2. A circular path, 42 m in diameter has a path 3.5 m wide running round it on the outside. Find the cost of gravelling the path at Rs. 4 per m².
(a) Rs. 2800 (b) Rs. 2020 (c) Rs. 2002 (d) none of these
3. A road which is 7m wide surrounds a circular park whose circumference is 352 m. Find the area of the road.
(a) 2618 m² (b) 2518 m² (c) 1618 m² (d) none of these
4. If the perimeter of a semicircular protractor is 36 cm, find the diameter.
(a) 14 cm (b) 16 cm (c) 18 cm (d) 12 cm
5. A bicycle wheel makes 5000 revolutions in moving 11 km. Find the diameter of the wheel.
(a) 60 cm (b) 70 cm (c) 66 cm (d) 68 cm
6. The diameter of the wheels of a bus is 140 cm. How many revolutions per minute must a wheel make in order to move at a speed of 66km/hr?
(a) 240 (b) 250 (c) 260 (d) 270
7. A paper is in the form of a rectangle ABCD in which AB = 18cm and BC = 14cm. A semicircular portion with BC as diameter is cut off. Find the area of the remaining paper (see in below figure).
(a) 175 cm² (b) 165 cm² (c) 145 cm² (d) none of these

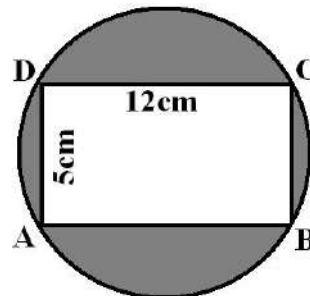
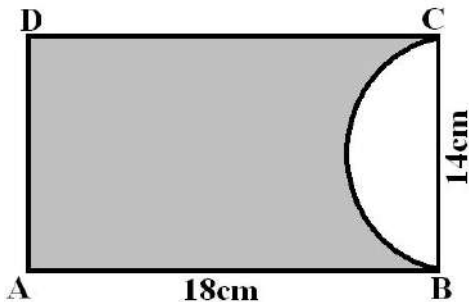

8. Find the area of the shaded region in the above sided figure. Take $\pi = 3.14$
(a) 75 cm² (b) 72 cm² (c) 70 cm² (d) none of these
9. A square ABCD is inscribed in a circle of radius 'r'. Find the area of the square in sq. units.
(a) 3r² (b) 2r² (c) 4r² (d) none of these
10. Find the area of a right-angled triangle, if the radius of its circumcircle is 2.5 cm and the altitude drawn to the hypotenuse is 2 cm long.
(a) 5 cm² (b) 6 cm² (c) 7 cm² (d) none of these

MCQ WORKSHEET-III
CLASS X: CHAPTER – 12
AREAS RELATED TO CIRCLES

- The perimeter of a sector of a circle of radius 5.6 cm is 27.2 cm. Find the area of the sector.
 (a) 44 cm^2 (b) 44.6 cm^2 (c) 44.8 cm^2 (d) none of these
- The minute hand of a clock is 12 cm long. Find the area of the face of the clock described by the minute hand in 35 minutes.
 (a) 265 cm^2 (b) 266 cm^2 (c) 264 cm^2 (d) none of these
- Find the area of the shaded region in the given figure, if $Pr = 24 \text{ cm}$, $PQ = 7 \text{ cm}$ and O is the centre of the circle.
 (a) 164.54 cm^2 (b) 161.54 cm^2 (c) 162.54 cm^2 (d) none of these

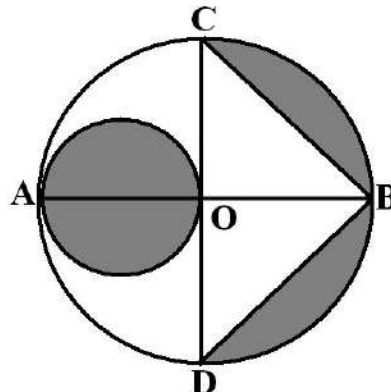
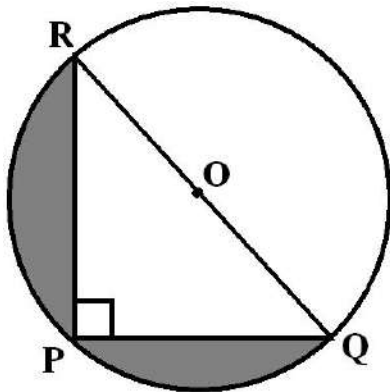

- In the above-sided figure, AB is a diameter of a circle with centre O and $OA = 7 \text{ cm}$. Find the area of the shaded region.
 (a) 64.5 cm^2 (b) 61.5 cm^2 (c) 66.5 cm^2 (d) none of these
- A racetrack is in the form of a ring whose inner circumference is 352 m and outer circumference is 396 m. Find the width of the track.
 (a) 4 m (b) 6 m (c) 8 m (d) 7 m
- The difference between the circumference and the radius of a circle is 37 cm. Find the area of the circle.
 (a) 111 cm^2 (b) 184 cm^2 (c) 154 cm^2 (d) 259 cm^2
- The circumference of a circle exceeds its diameter by 16.8 cm. Find the circumference of the circle.
 (a) 24.64 cm (b) 26.64 cm (c) 28.64 cm (d) 22 cm
- A copper wire when bent in the form of square encloses an area of 484 cm^2 . The same wire is now bent in the form of a circle. Find the area of the circle.
 (a) 116 cm^2 (b) 166 cm^2 (c) 616 cm^2 (d) none of these
- Find the area of the sector of a circle of radius 14 cm with central angle 45° .
 (a) 76 cm^2 (b) 77 cm^2 (c) 66 cm^2 (d) none of these
- A sector is cut from a circle of radius 21 cm. The angle of the sector is 150° . Find the length of the arc.
 (a) 56 cm (b) 57 cm (c) 55 cm (d) 58 cm

MCQ WORKSHEET-IV
CLASS X: CHAPTER – 12
AREAS RELATED TO CIRCLES

1. The area of the sector of a circle of radius r and central angle θ , is
A. $\frac{1}{2}lr$ B. $2\pi r^2\theta/720$ C. $2\pi r\theta/360$ D. $\pi r\theta/360$
2. An arc of a circle is of length 5π cm and the sector it bounds has an area of 20π cm². The radius of circle is
A. 1 cm B. 5 cm C. 8 cm D. 10 cm
3. A sector is cut from a circle of radius 21 cm. The angle of sector is 150° . The area of sector is
A. 577.5 cm² B. 288.2 cm² C. 152 cm² D. 155 m²
4. A chord AB of a circle of radius 10 cm makes a right angle at the centre of the circle. The area of major segment is
A. 210 cm² B. 235.7 cm² C. 185.5 cm² D. 258.1 cm²
5. A horse is tied to a pole with 56 m long string. The area of the field where the horse can graze is
A. 2560 m² B. 2464 m² C. 9856 m² D. 25600 m²
6. The circumferences of two circles are in the ratio 2:3. The ratio of their areas is
A. 4:9 B. 2:3 C. 7:9 D. 4:10
7. Area enclosed between two concentric circles is 770 cm². If the radius of outer circle is 21 cm, then the radius of inner circle is
A. 12 cm B. 13 cm C. 14 cm D. 15 cm
8. The perimeter of a semi-circular protector is 72 cm. Its diameter is
A. 28 cm B. 14 cm C. 36 cm D. 24 cm
9. The minute hand of a clock is 21 cm long. The area described by it on the face of clock in 5 minutes is
A. 115.5 cm² B. 112.5 cm² C. 211.5 cm² D. 123.5 cm²
10. The area of a circle circumscribing a square of area 64 cm² is
A. 50.28 cm² B. 25.5 cm² C. 100.57 cm² D. 75.48 cm²
11. A pendulum swings through an angle of 30° and describes an arc 8.8 cm in length. Find the length of the pendulum.
(a) 16 cm (b) 16.5 cm (c) 16.8 cm (d) 17 cm

12. The minute hand of a clock is 15 cm long. Calculate the area swept by it in 20 minutes. Take $\pi=3.14$
(a) 116 cm^2 (b) 166 cm^2 (c) 616 cm^2 (d) none of these
13. A sector of 56° , cut out from a circle, contains 17.6 cm^2 . Find the radius of the circle.
(a) 6 cm (b) 7 cm (c) 5 cm (d) 8 cm
14. A chord 10 cm long is drawn in a circle whose radius is $5\sqrt{2}$ cm. Find the areas of minor segment. Take $\pi=3.14$
(a) 16 cm^2 (b) 14.5 cm^2 (c) 14.25 cm^2 (d) none of these
15. The circumference of a circle is 88 cm. Find the area of the sector whose central angle is 72° .
(a) 123 cm^2 (b) 123.5 cm^2 (c) 123.4 cm^2 (d) none of these
-

PRACTICE QUESTIONS
CLASS X: CHAPTER – 12
AREAS RELATED TO CIRCLES

1. If the perimeter of a semicircular protractor is 36 cm, find its diameter.
2. A bicycle wheel makes 5000 revolutions in moving 11 km. Find the diameter of the wheel.
3. The diameter of the wheels of a bus is 140 cm. How many revolutions per minute must a wheel make in order to move at a speed of 66 km per hour?
4. Two circles touch externally. The sum of their areas is 130π sq. cm and the distance between their centres is 14 cm. Find the radii of the circles.
5. Two circles touch internally. The sum of their areas is 116π sq. cm and the distance between their centres is 6 cm. Find the radii of the circles.
6. A paper is in the form of a rectangle ABCD in which AB = 18 cm and BC = 14 cm. A semicircular portion with BC as diameter is cut off. Find the area of the remaining paper.
7. A square ABCD is inscribed in a circle of radius r. Find the area of the square.
8. Find the area of a right-angled triangle, if the radius of its circumcircle is 2.5cm and the altitude drawn to the hypotenuse is 2cm long.
9. A steel wire, bent in the form of a square, encloses an area of 121 sq. cm. The same wire is bent in the form of a circle. Find the area of the circle.
10. A wire is looped in the form of a circle of radius 28 cm. It is rebent into a square form. Determine the length of the side of the square.
11. A circular park, 42 m diameter, has a path 3.5 m wide running round it on the outside. Find the cost of gravelling the path at Rs. 4 per m^2 .
12. A road, which is 7m wide, surrounds a circular park whose circumference is 352m. Find the area of the road.
13. A racetrack is in the form of a ring whose inner and outer circumference are 437 m and 503 m respectively. Find the width of the track and also its area.
14. From a circular sheet of radius 4 cm, a circle of radius 3 cm is removed. Find the area of the remaining sheet. (Take $\pi = 3.14$)
15. Saima wants to put a lace on the edge of a circular table cover of diameter 1.5 m. Find the length of the lace required and also find its cost if one meter of the lace costs Rs 15. (Take $\pi = 3.14$)
16. A circle of radius 2 cm is cut out from a square piece of an aluminium sheet of side 6 cm. What is the area of the left over aluminium sheet? (Take $\pi = 3.14$)
17. The circumference of a circle is 31.4 cm. Find the radius and the area of the circle? (Take $\pi = 3.14$)

18. The shape of a garden is rectangular in the middle and semi circular at the ends as shown in the diagram. Find the area and the perimeter of this garden

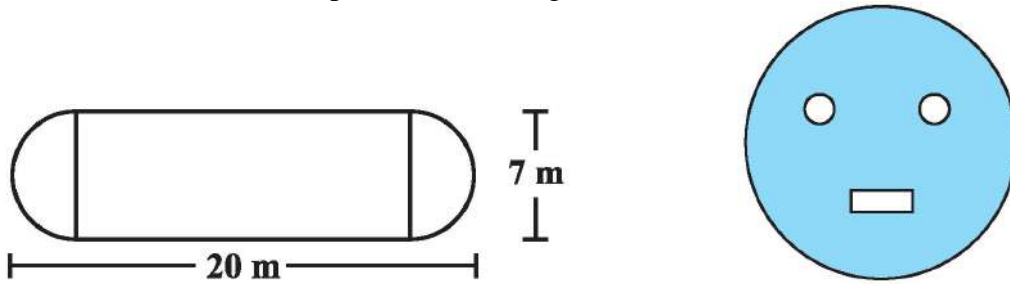

19. From a circular card sheet of radius 14 cm, two circles of radius 3.5 cm and a rectangle of length 3 cm and breadth 1cm are removed. (as shown in the right sided adjoining figure). Find the area of the remaining sheet.

20. A circular flower bed is surrounded by a path 4 m wide. The diameter of the flower bed is 66 m. What is the area of this path? ($\pi = 3.14$)

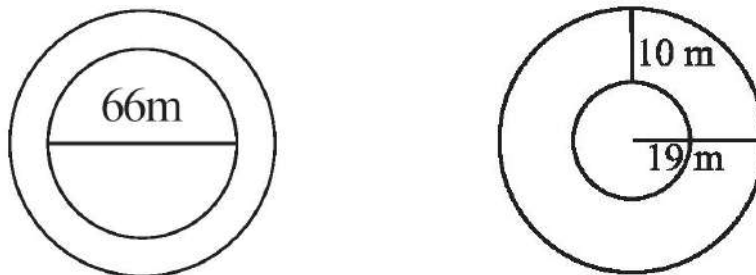

21. Find the circumference of the inner and the outer circles, shown in the right sided adjoining figure? (Take $\pi = 3.14$)
22. Shazli took a wire of length 44 cm and bent it into the shape of a circle. Find the radius of that circle. Also find its area. If the same wire is bent into the shape of a square, what will be the length of each of its sides? Which figure encloses more area, the circle or the square?
23. A circular flower garden has an area of 314 m^2 . A sprinkler at the centre of the garden can cover an area that has a radius of 12 m. Will the sprinkler water the entire garden? (Take $\pi = 3.14$)
24. How many times a wheel of radius 28 cm must rotate to go 352 m? (Take $\pi = \frac{22}{7}$)
25. Three horses are tethered with 7 m long ropes at the three corners of a triangular field having sides 20m, 34 m and 42 m. Find the area of the plot which can be grazed by the horses. Also, find the area of the plot, which remains ungrazed.

26. Find the area of a ΔCAB with $\angle ACB = 120^\circ$ & $CA = CB = 18 \text{ cm}$.

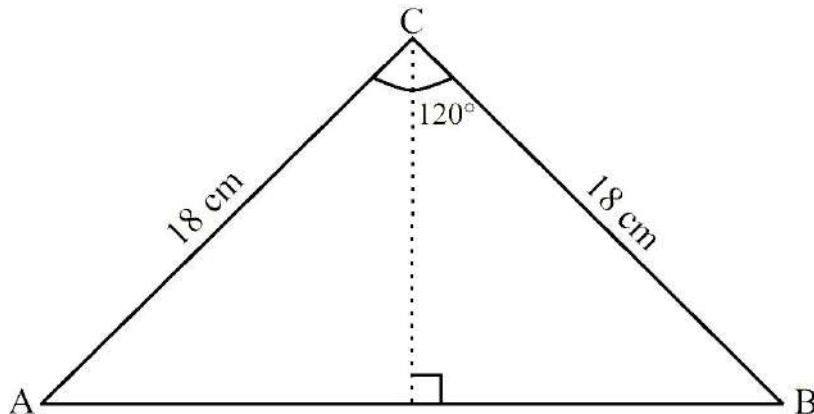

27. Find the area of sector of angle 120° and radius 18 cm.

28. Find the area of the segment AOB of angle 120° and radius 18 cm.
29. The minute hand of a circular clock is 15 cm long. Find the area of the face of the clock and how far does the tip of the minute hand move in 35 minutes? (Take $\pi = 3.14$)
30. Find the cost of polishing a circular table-top of diameter 1.6 m, if the rate of polishing is Rs $15/\text{m}^2$. (Take $\pi = 3.14$)
31. A chord of a circle of radius 14 cm makes a right angle at the centre. Find the areas of the minor and the major segments of the circle.
32. A square tank has area of 1600 m^2 . There are four semicircular plots around it. Find the cost of turfing the plots at Rs. 1.25 per m^2 . Take $\pi = 3.14$.
33. A lawn is rectangular in the middle and it has semicircular portions along the shorter sides of the rectangle. The rectangular portion measures 50m by 35m. Find the area of the lawn.
34. A rope by which a cow is tethered is increased from 16 m to 23 m. How much additional ground does it have now to graze?
35. The perimeter of a certain sector of a circle of radius 6.5 cm is 31 cm. Find the area of the sector.
36. The area of the sector of a circle of radius 10.5 cm is 69.3 cm^2 . Find the central angle of the sector.
37. A sector of 56° cut out from a circle, contains 17.6 cm^2 . Find the radius of the circle.
38. The short and long hands of a clock are 4 cm and 6 cm long respectively. Find the sum of distances travelled by their tips in 2 days. Take $\pi = 3.14$.
39. Find the lengths of the arcs cut off from a circle of radius 12 cm by a chord 12 cm long. Also find the area of the minor segment. Take $\sqrt{3} = 1.73$ and $\pi = 3.14$.
40. The perimeter of a sector of a circle of radius 5.6 cm is 27.2 cm. Find the area of the sector.
41. A chord of a circle of radius 10 cm subtends a right angle at the centre. Find the following: (i) Area of minor sector (ii) Area of major sector (iii) Area of major segment (iv) Area of minor segment. (Use $\pi = 3.14$)
42. In a circle of radius 10.5 cm, the minor arc is one-fifth of the major arc. Find the area of the sector corresponding to the major arc.
43. It is proposed to add two circular ends, to a square lawn whose side measures 58 cm, the centre of each circle being the point of intersection of the diagonals of the square. Find the area of the whole lawn.
44. It is proposed to add two circular ends, to a square lawn whose side measures 50 m, the centre of each circle being the point of intersection of the diagonals of the square. Find the area of the whole lawn. Take $\pi = 3.14$
45. In an equilateral triangle of side 12 cm, a circle is inscribed touching its sides. Find the area of the portion of the triangle not included in the circle. Take $\sqrt{3} = 1.73$ and $\pi = 3.14$.

46. In a circle of radius 21 cm, an arc subtends an angle of 60° at the centre. Find (i) length of the arc (ii) area of sector formed by the arc (iii) area of segment formed by the corresponding chord of the arc.
47. If three circles of radius r each, are drawn such that each touches the other two, the find the area included between them. Take $\pi = 3.14$ and $\sqrt{3} = 1.73$.
48. If four circles of radius r each, are drawn such that each touches the other two, the find the area included between them. Take $\pi = 3.14$.
49. The length of an arc subtending an angle of 72° at the centre is 44 cm. Find the area of the circle.
50. A park is in the form of rectangle 120 m by 100 m. At the centre of the park, there is a circular lawn. The area of the park excluding the lawn is 11384 sq. m. Find the radius of the circular lawn.
51. Find the area of shaded portion in the below figure

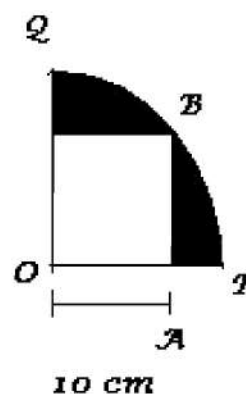
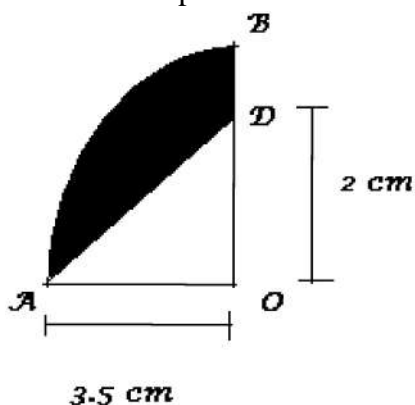

52. Find the area of shaded portion in the above right-sided figure
53. Find the area of shaded portion in the below figure

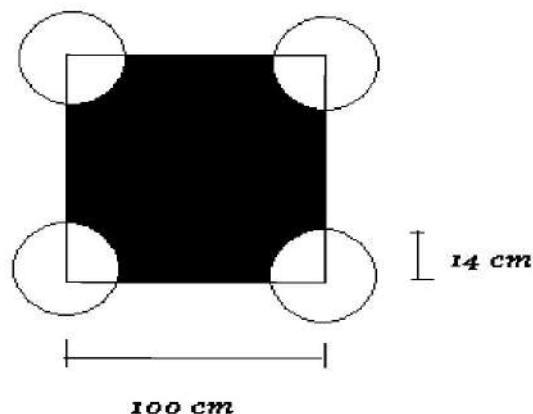
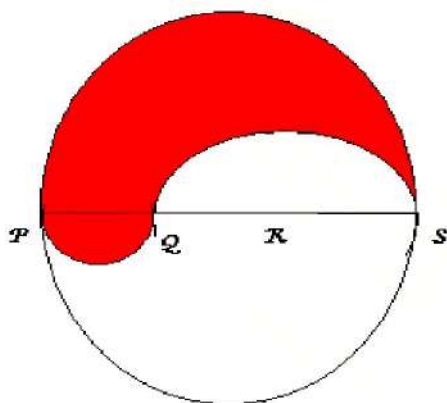

54. Find the area of shaded portion in the above right-sided figure
55. An athletic track, 14 m wide, consists of two straight sections 120 m long joining semicircular ends whose inner radius is 35 m. Calculate the area of the track.
56. The cost of fencing a circular field at the rate of Rs 24 per metre is Rs 5280. The field is to be ploughed at the rate of Rs 0.50 per m². Find the cost of ploughing the field.

57. The radii of two circles are 8 cm and 6 cm respectively. Find the radius of the circle having area equal to the sum of the areas of the two circles.
58. The radii of two circles are 19 cm and 9 cm respectively. Find the radius of the circle which has circumference equal to the sum of the circumferences of the two circles.
59. The wheels of a car are of diameter 80 cm each. How many complete revolutions does each wheel make in 10 minutes when the car is travelling at a speed of 66 km per hour?

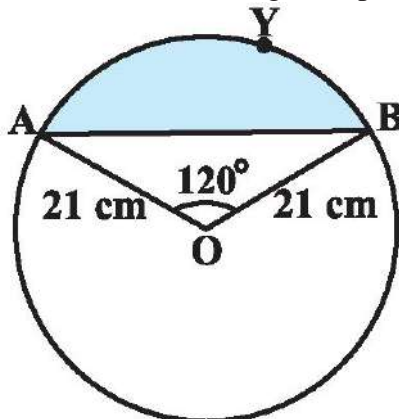

60. Find the area of the segment AYB shown in Fig., if radius of the circle is 21 cm and $\angle AOB = 120^\circ$. (Use $\pi = 22/7$).
61. Find the area of the sector of a circle with radius 4 cm and of angle 30° . Also, find the area of the corresponding major sector (Use $\pi = 3.14$).
62. Find the area of a sector of a circle with radius 6 cm if angle of the sector is 60° .
63. Find the area of a quadrant of a circle whose circumference is 22 cm.
64. The length of the minute hand of a clock is 14 cm. Find the area swept by the minute hand in 5 minutes.
65. A chord of a circle of radius 10 cm subtends a right angle at the centre. Find the area of the corresponding : (i) minor segment (ii) major sector. (Use $\pi = 3.14$)
66. In a circle of radius 21 cm, an arc subtends an angle of 60° at the centre. Find: (i) the length of the arc (ii) area of the sector formed by the arc (iii) area of the segment formed by the corresponding chord
67. A chord of a circle of radius 15 cm subtends an angle of 60° at the centre. Find the areas of the corresponding minor and major segments of the circle. (Use $\pi = 3.14$ and $\sqrt{3} = 1.73$)
68. A chord of a circle of radius 12 cm subtends an angle of 120° at the centre. Find the area of the corresponding segment of the circle. (Use $\pi = 3.14$ and $\sqrt{3} = 1.73$)
69. In Fig, two circular flower beds have been shown on two sides of a square lawn ABCD of side 56 m. If the centre of each circular flower bed is the point of intersection O of the diagonals of the square lawn, find the sum of the areas of the lawn and the flower beds.

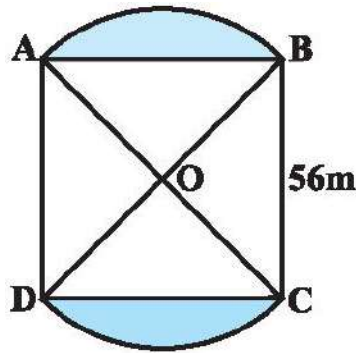

70. Find the area of the shaded region in the below Fig., where ABCD is a square of side 14 cm.

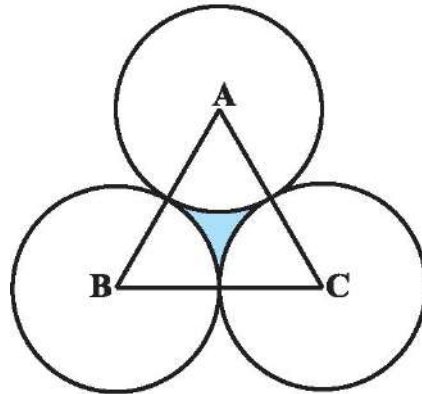
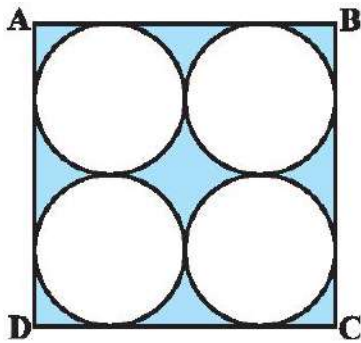

71. The area of an equilateral triangle ABC is 17320.5 cm^2 . With each vertex of the triangle as centre, a circle is drawn with radius equal to half the length of the side of the triangle. Find the area of the shaded region. . (Use $\pi = 3.14$ and $\sqrt{3} = 1.73205$)

72. An umbrella has 8 ribs which are equally spaced. Assuming umbrella to be a flat circle of radius 45 cm, find the area between the two consecutive ribs of the umbrella.

73. A horse is tied to a peg at one corner of a square shaped grass field of side 15 m by means of a 5 m long rope. Find (i) the area of that part of the field in which the horse can graze. (ii) the increase in the grazing area if the rope were 10 m long instead of 5 m. . (Use $\pi = 3.14$)

74. In Fig., ABCD is a square of side 14 cm. With centres A, B, C and D, four circles are drawn such that each circle touch externally two of the remaining three circles. Find the area of the shaded region.

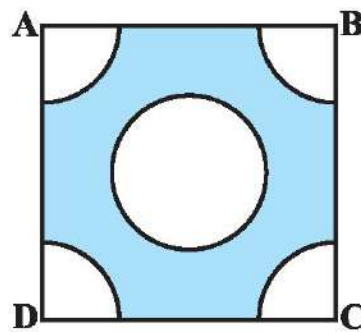
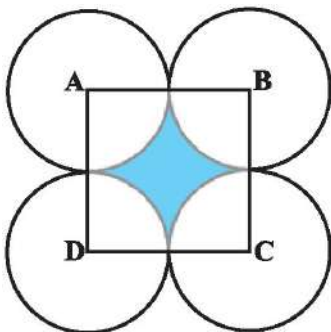

75. From each corner of a square of side 4 cm a quadrant of a circle of radius 1 cm is cut and also a circle of diameter 2 cm is cut as shown in above sided Fig. Find the area of the remaining portion of the square.

76. Find the area of the shaded design in the below Fig., where ABCD is a square of side 10 cm and semicircles are drawn with each side of the square as diameter. (Use $\pi = 3.14$)

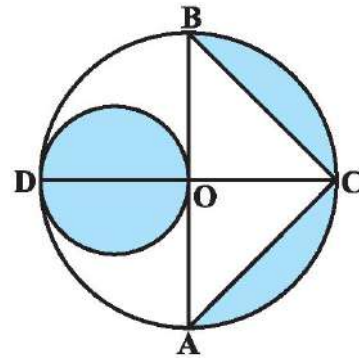
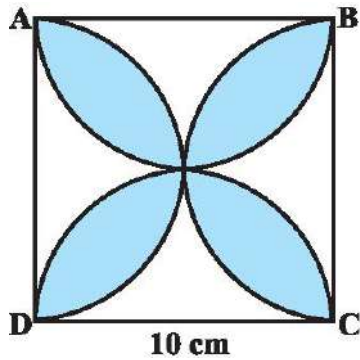

77. In the above sided Fig., AB and CD are two diameters of a circle (with centre O) perpendicular to each other and OD is the diameter of the smaller circle. If $OA = 7$ cm, find the area of the shaded region.

78. In a circular table cover of radius 32 cm, a design is formed leaving an equilateral triangle ABC in the middle as shown in Fig. Find the area of the design (shaded region).

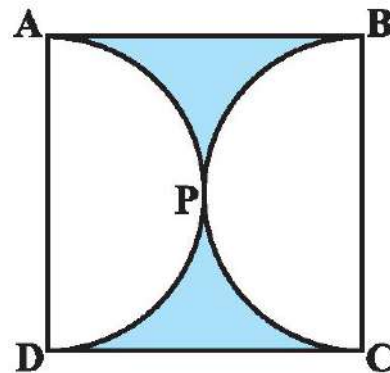
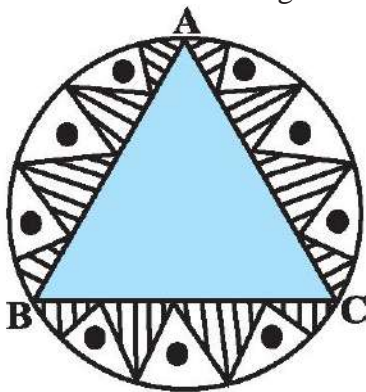

79. Find the area of the shaded region in above sided Fig., if ABCD is a square of side 14 cm and APD and BPC are semicircles.

80. To warn ships for underwater rocks, a lighthouse spreads a red coloured light over a sector of angle 80° to a distance of 16.5 km. Find the area of the sea over which the ships are warned. . (Use $\pi = 3.14$)

81. In Fig., ABC is a quadrant of a circle of radius 14 cm and a semicircle is drawn with BC as diameter. Find the area of the shaded region.

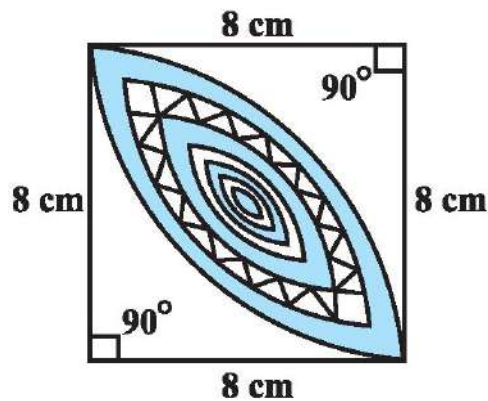
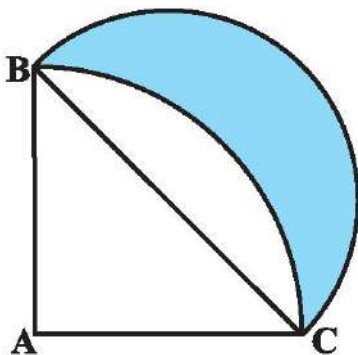

82. Calculate the area of the designed region in the above sided Fig. common between the two quadrants of circles of radius 8 cm each.

83. In Fig., a square OABC is inscribed in a quadrant OPBQ. If OA = 20 cm, find the area of the shaded region. (Use $\pi = 3.14$)

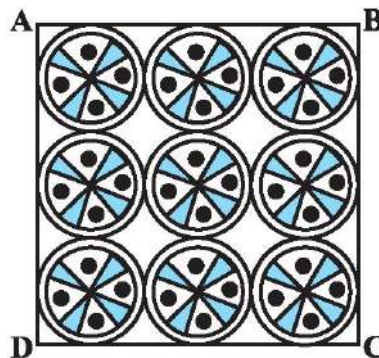
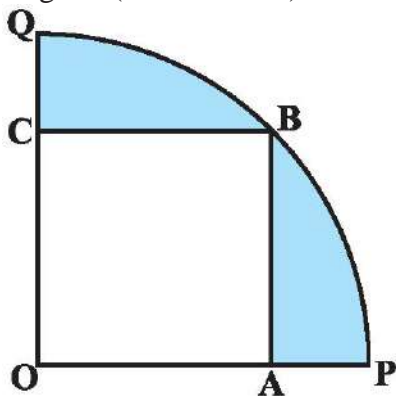

84. On a square handkerchief, nine circular designs each of radius 7 cm are made (see in the above sided Fig.). Find the area of the remaining portion of the handkerchief.

85. In the given figure, ΔABC is right angled at A. Semicircles are drawn on AB, AC and BC as diameters. It is given that AB = 3cm and AC = 4cm. Find the area of the shaded region.

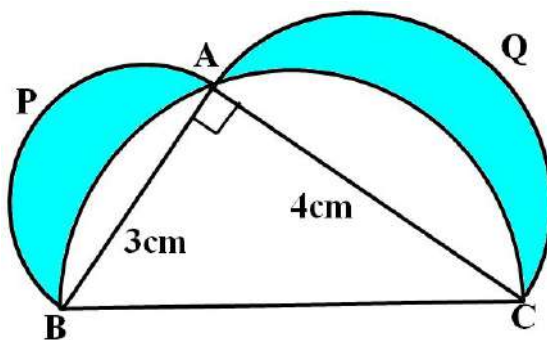

86. Find the area of the shaded region in the below figure, if PQ = 24 cm, PR = 7 cm and O is the centre of the circle.

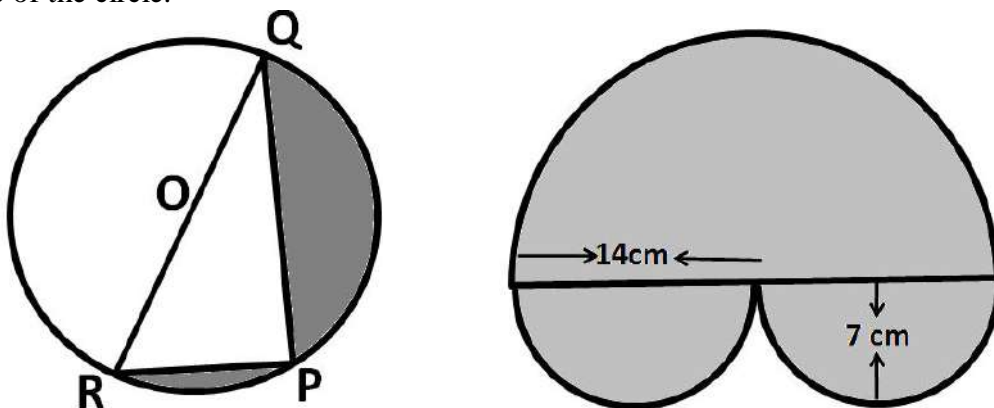

87. Find the areas of the shaded region in the above right sided figure.

88. In an equilateral triangle of side 24 cm, a circle is inscribed touching its sides. Find the area of the remaining portion of the triangle. Take $\sqrt{3} = 1.732$

89. Find to the three places of decimals the radius of the circle whose area is the sum of the areas of two triangles whose sides are 35, 53, 66 and 33, 56, 65 measured in cms. (Take $\pi = \frac{22}{7}$)

90. A square park has each side of 100m. At each corner of the park, there is a slower bed in the form of a quadrant of radius 14 m. Find the area of the remaining part of the park. (Take $\pi = \frac{22}{7}$)

91. Find the area of the shaded region in below figure, where radii of the two concentric circles with centre O are 7 cm and 14 cm respectively and $\angle AOC = 40^\circ$.

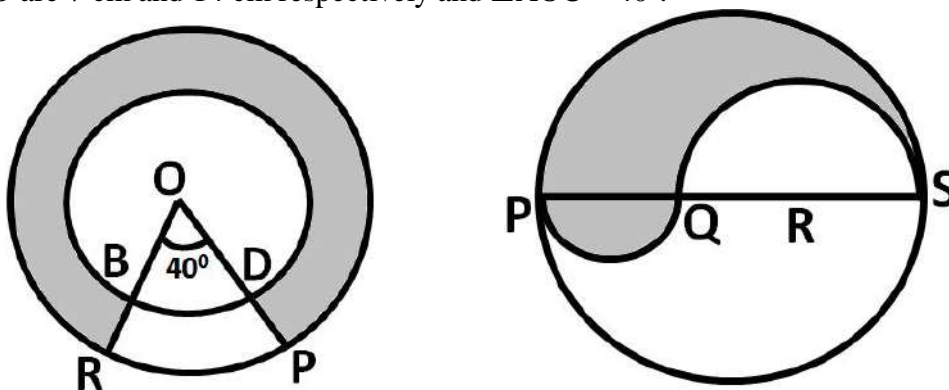

92. PQRS is a diameter of a circle of radius 6 cm. The lengths PQ, QR and RS are equal. Semicircles are drawn on PQ and QS as diameters as shown in above right sided figure. Find the perimeter and area of the shaded region.
93. An athletic track 14 m wide consists of two straight sections 120 m long joining semicircular ends whose inner radius is 35m. Calculate the area of the shaded region.



94. The above right-sided figure depicts a racing track whose left and right ends are semicircular. The distance between the two inner parallel line segments is 60 m and they are each 106 m long. If the track is 10 m wide, find : (i) the distance around the track along its inner edge (ii) the area of the track.
95. AB and CD are respectively arcs of two concentric circles of radii 21 cm and 7 cm and centre O (see below Figure). If $\angle AOB = 30^\circ$, find the area of the shaded region.

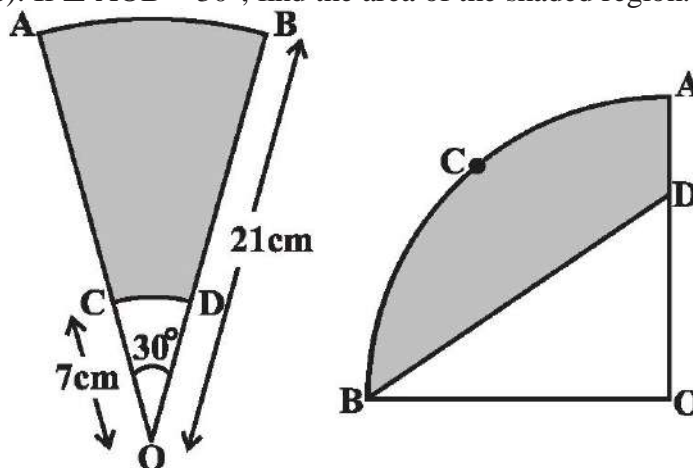

96. In the above right sided Figure, OACB is a quadrant of a circle with centre O and radius 3.5 cm. If $OD = 2$ cm, find the area of the (i) quadrant OACB, (ii) shaded region.
97. A path of 4m width runs round a semicircular grassy plot whose circumference is $163\frac{3}{7}$ m. Find (i) the area of the path (ii) the cost of gravelling the path at the rate of Rs. 1.50 per sq. m (iii) the cost of turfing the plot at the rate of 45 paise per sq. m.

98. Find the area of the shaded region in below figure, where a circular arc of radius 6 cm has been drawn with vertex O of an equilateral triangle OAB of side 12 cm as centre.

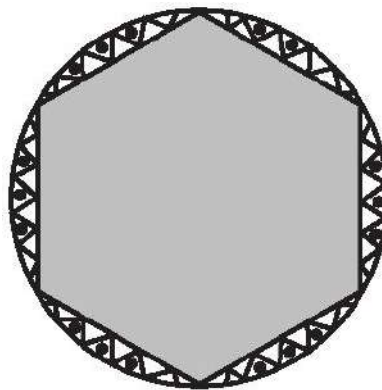
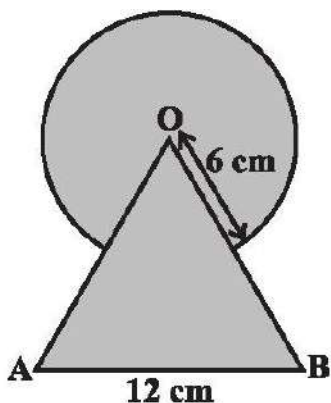

99. A round table cover has six equal designs as shown in the above right-sided figure. If the radius of the cover is 28 cm, find the cost of making the designs at the rate of Rs 0.35 per cm^2 . (Use $\sqrt{3} = 1.7$)

100. Find the area of the shaded region in the below figure, if radii of the two concentric circles with centre O are 7 cm and 14 cm respectively and $\angle AOC = 40^\circ$.

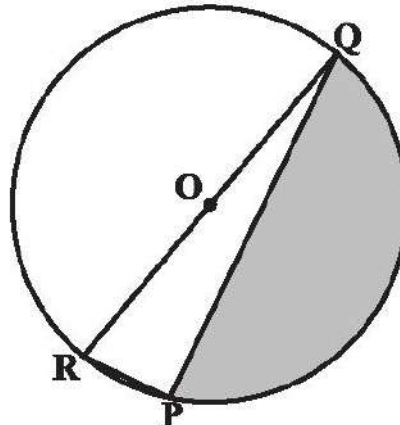
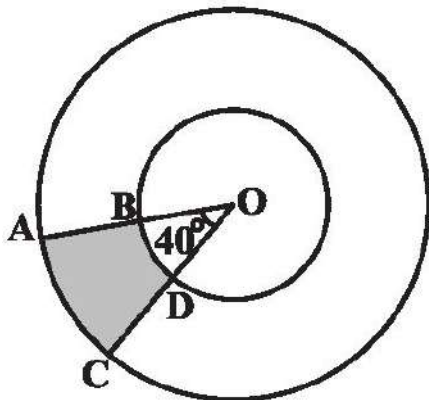

101. Find the area of the shaded region in the above right-sided figure, if $PQ = 24$ cm, $PR = 7$ cm and O is the centre of the circle.
102. A brooch is made with silver wire in the form of a circle with diameter 35 mm. The wire is also used in making 5 diameters which divide the circle into 10 equal sectors as shown in below figure. Find : (i) the total length of the silver wire required. (ii) the area of each sector of the brooch.

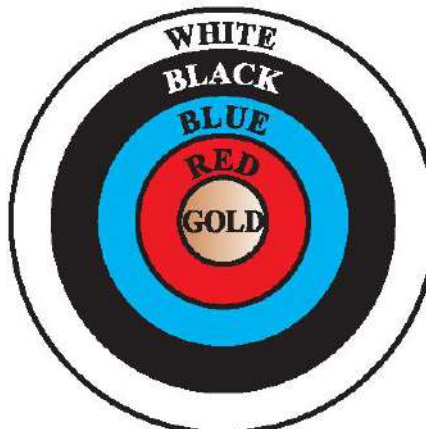
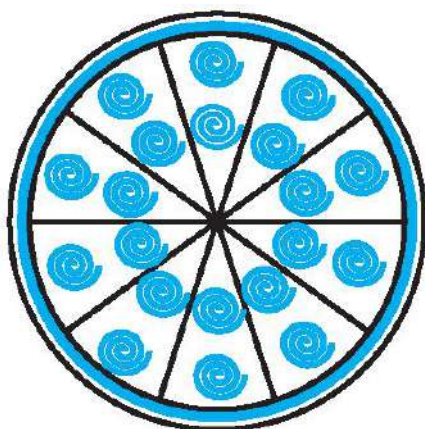

103. The area of a sector is one-twelfth that of the complete circle. Find the angle of the sector.
104. Find the area of the circle in which a square of area 64 sq. cm is inscribed. (use $\pi = 3.14$)

105. In the below figure, ABC is right angled triangle at A. Find the area of the shaded region, if AB = 6cm and BC = 10cm..

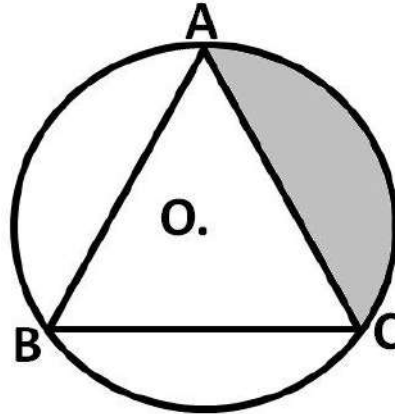
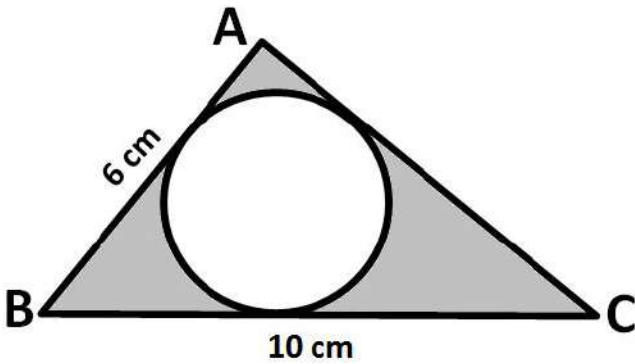

106. In the above right-sided figure, ABC is an equilateral triangle inscribed in a circle of radius 4 cm with centre O. Find the area of the shaded region.
107. The diameter of a coin is 1 cm see the below figure. If four such coins be placed on a table so that the rim of each touches that of the other two, find the area of the shaded region. (use $\pi = 3.1416$)

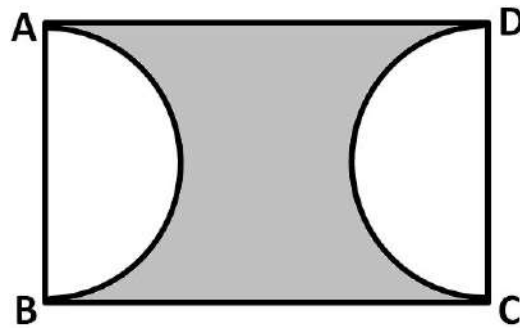
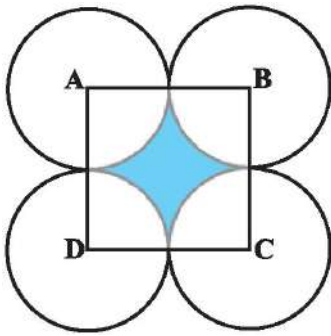

108. In the above right-sided figure, ABCD is a rectangle, having AB = 14 cm and BC = 20 cm. Two sectors of 180° have been cut off. Calculate (i) area of the shaded region (ii) length of the boundary of the shaded region.
109. Find the area of the shaded region given in below Figure

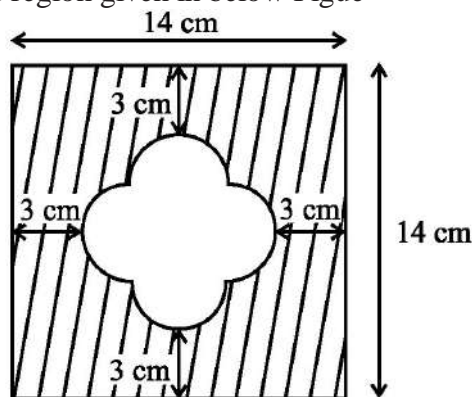

110. Find the number of revolutions made by a circular wheel of area 1.54 m² in rolling a distance of 176 m.
111. Find the difference of the areas of two segments of a circle formed by a chord of length 5 cm subtending an angle of 90° at the centre.

112. Find the difference of the areas of a sector of angle 120° and its corresponding major sector of a circle of radius 21 cm.
113. The central angles of two sectors of circles of radii 7 cm and 21 cm are respectively 120° and 40° . Find the areas of the two sectors as well as the lengths of the corresponding arcs.
114. The length of the minute hand of a clock is 5 cm. Find the area swept by the minute hand during the time period 6:05 a.m. and 6:40 a.m.
115. All the vertices of a rhombus lie on a circle. Find the area of the rhombus, if area of the circle is 1256 cm^2 . (Use $\pi = 3.14$).
116. An archery target has three regions formed by three concentric circles as shown in the below figure. If the diameters of the concentric circles are in the ratio 1: 2:3, then find the ratio of the areas of three regions.

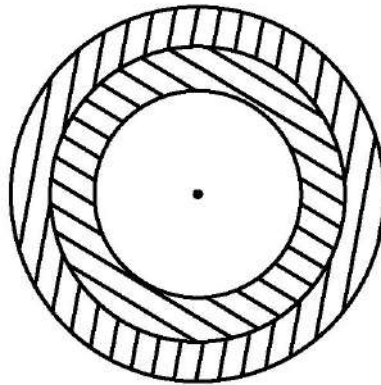

117. Area of a sector of central angle 200° of a circle is 770 cm^2 . Find the length of the corresponding arc of this sector.
118. Three circles each of radius 3.5 cm are drawn in such a way that each of them touches the other two. Find the area enclosed between these circles.
119. Find the area of the sector of a circle of radius 5 cm, if the corresponding arc length is 3.5 cm.
120. Four circular cardboard pieces of radii 7 cm are placed on a paper in such a way that each piece touches other two pieces. Find the area of the portion enclosed between these pieces.
121. On a square cardboard sheet of area 784 cm^2 , four congruent circular plates of maximum size are placed such that each circular plate touches the other two plates and each side of the square sheet is tangent to two circular plates. Find the area of the square sheet not covered by the circular plates.
122. Floor of a room is of dimensions $5 \text{ m} \times 4 \text{ m}$ and it is covered with circular tiles of diameters 50 cm each as shown in the below figure. Find the area of floor which is not covered by tiles.

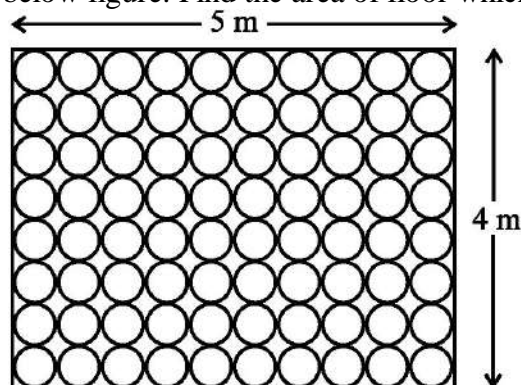

123. With the vertices A, B and C of a triangle ABC as centres, arcs are drawn with radii 5 cm each as shown in below figure. If $AB = 14$ cm, $BC = 48$ cm and $CA = 50$ cm, then find the area of the shaded region. (Use $\pi = 3.14$).

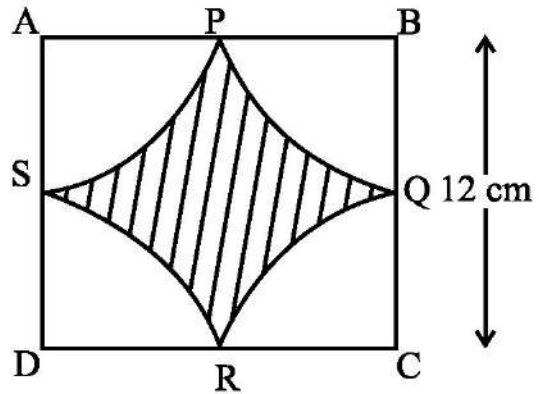
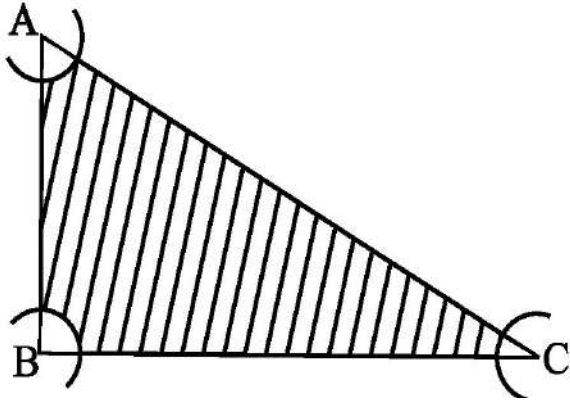

124. Find the area of the shaded region in the above right sided figure, where arcs drawn with centres A, B, C and D intersect in pairs at mid-points P, Q, R and S of the sides AB, BC, CD and DA, respectively of a square ABCD (Use $\pi = 3.14$).
125. Find the area of the shaded field shown in the below figure.

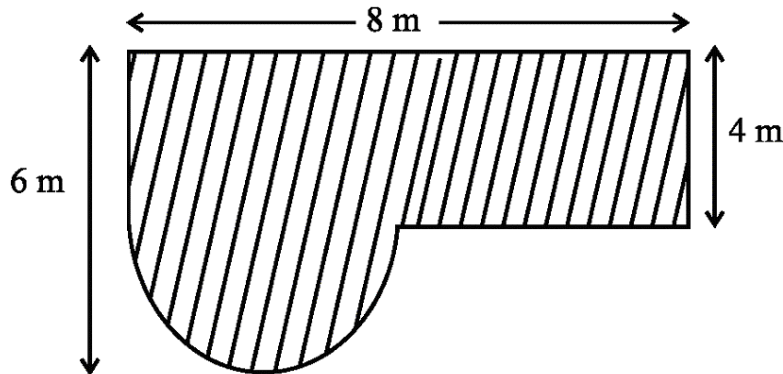

126. A calf is tied with a rope of length 6 m at the corner of a square grassy lawn of side 20 m. If the length of the rope is increased by 5.5m, find the increase in area of the grassy lawn in which the calf can graze.

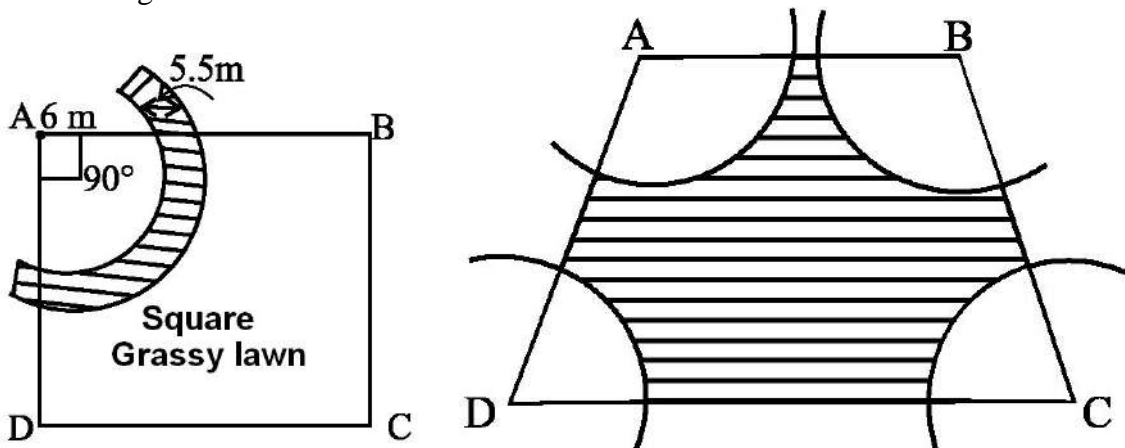

127. In the above right sided figure, ABCD is a trapezium with $AB \parallel DC$, $AB = 18$ cm, $DC = 32$ cm and distance between AB and DC = 14 cm. If arcs of equal radii 7 cm with centres A, B, C and D have been drawn, then find the area of the shaded region of the figure.
128. A circular pond is 17.5 m is of diameter. It is surrounded by a 2 m wide path. Find the cost of constructing the path at the rate of Rs 25 per m^2
129. A circular park is surrounded by a road 21 m wide. If the radius of the park is 105 m, find the area of the road.

130. In the below figure, arcs are drawn by taking vertices A, B and C of an equilateral triangle of side 10 cm. to intersect the sides BC, CA and AB at their respective mid-points D, E and F. Find the area of the shaded region (Use $\pi = 3.14$).

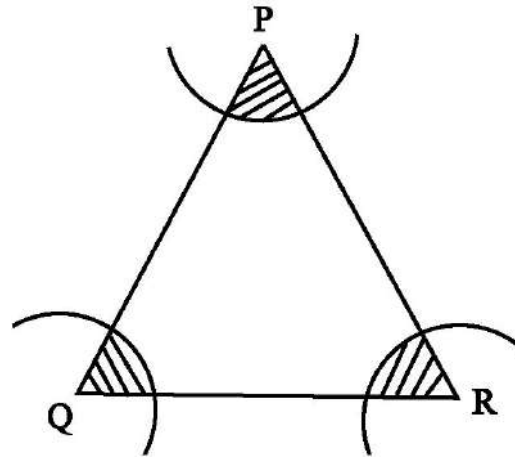
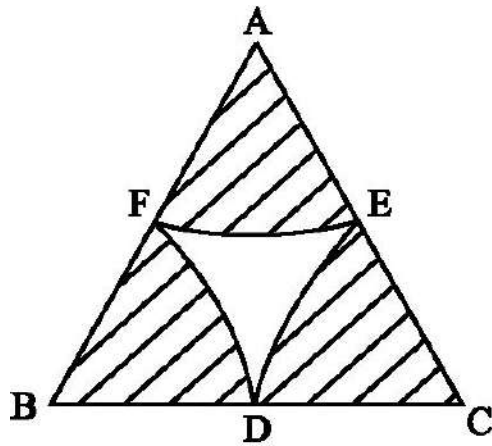

131. In the above right sided figure, arcs have been drawn with radii 14 cm each and with centres P, Q and R. Find the area of the shaded region.

132. In the below figure, arcs have been drawn of radius 21 cm each with vertices A, B, C and D of quadrilateral ABCD as centres. Find the area of the shaded region.

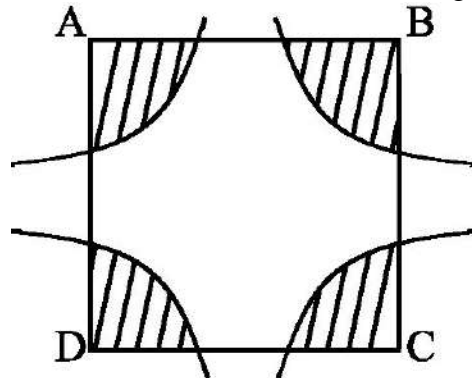

133. A piece of wire 20 cm long is bent into the form of an arc of a circle subtending an angle of 60° at its centre. Find the radius of the circle.



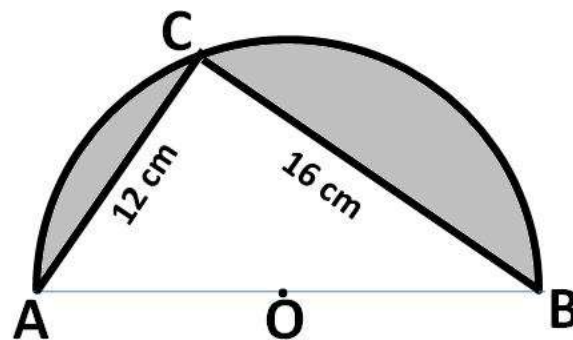
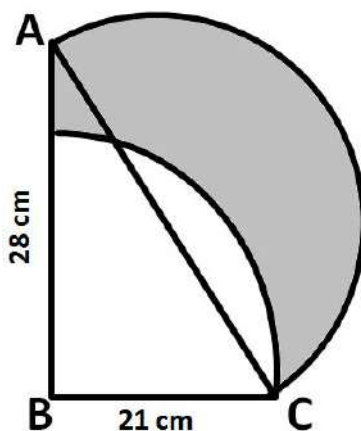



134. In the below figure, ABC is a right angled triangle at B, $AB = 28$ cm and $BC = 21$ cm. With diameter a semicircle is drawn and with BC as radius a quarter circle is drawn. Find the area of the shaded region correct to two decimal places.

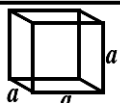

135. In the above right-sided figure, O is the centre of a circular arc and AOB is a straight line. Find the perimeter and the area of the shaded region. (use $\pi = 3.142$)

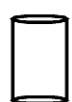
CLASS X : CHAPTER - 13
SURFACE AREAS AND VOLUMES

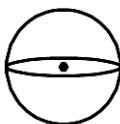
IMPORTANT FORMULAS & CONCEPTS

S. No.	Name of the solid	Figure	Lateral / Curved surface area	Total surface area	Volume	Nomenclature
1.	Cuboid		$2h(l+b)$	$2(lb+bh+hl)$	lbh	l :length b :breadth h :height
2.	Cube		$4a^2$	$6a^2$	a^3	a :side of the cube
3.	Right prism		Perimeter of base \times height	Lateral surface area+2(area of the end surface)	area of base \times height	-
4.	Regular circular Cylinder		$2\pi rh$	$2\pi r(r+h)$	$\pi r^2 h$	r :radius of the base h :height
5.	Right pyramid		$\frac{1}{2}$ (perimeter of base) \times slant height	Lateral surfaces area+area of the base	$\frac{1}{3}$ area of the base \times height	-
6.	Right circular cone		πrl	$\pi r(l+r)$	$\frac{1}{3} \pi r^2 h$	r :radius of the base h :height l :slant height
7.	Sphere		$4\pi r^2$	$4\pi r^2$	$\frac{4}{3} \pi r^3$	r :radius
8.	Hemisphere		$2\pi r^2$	$3\pi r^2$	$\frac{2}{3} \pi r^3$	r :radius

Frustum of a Cone - If a right circular cone is cut off by a plane parallel to its base, then the portion of the cone between the cutting plane and the base of the cone is called a frustum of a cone.

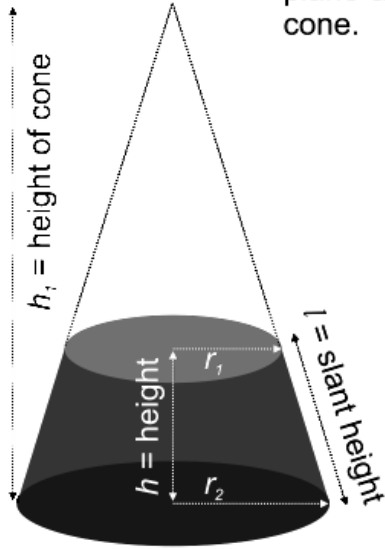

Slant Height of Frustum (l)	$\sqrt{h^2 + (r_1 - r_2)^2}$
Lateral Surface Area	$\pi (r_1 + r_2) l$
Total Surface Area	$\pi \{ (r_1 + r_2) l + r_1^2 + r_2^2 \}$
Volume	$\frac{\pi}{3} (r_1^2 + r_1 r_2 + r_2^2) h$
Height of cone of which the frustum is part of (h₁)	$\frac{h r_1}{(r_1 - r_2)}$



MCQ WORKSHEET-I
CLASS X: CHAPTER – 13
SURFACE AREAS AND VOLUMES

1. The surface area of a cuboid is
(a) $2(lb + bh + lh)$ (b) $3(lb + bh + lh)$ (c) $2(lb - bh - lh)$ (d) $3(lb - bh - lh)$
2. The surface area of a cube if edge 'a' is
(a) $7a^2$ (b) $6a^2$ (c) $5a^3$ (d) $5a^2$
3. The length, breadth and height of a room is 5m, 4m and 3m. The cost of white washing its four walls at the rate of Rs. 7.50 per m^2 is
(a) Rs. 110 (b) Rs. 109 (c) Rs. 220 (d) Rs. 105
4. The perimeter of floor of rectangular hall is 250m. The cost of the white washing its four walls is Rs. 15000. The height of the room is
(a) 5m (b) 4m (c) 6m (d) 8m
5. The breadth of a room is twice its height and is half of its length. The volume of room is $512dm^3$. Its dimensions are
(a) 16 dm, 8 dm, 4 dm (b) 12 dm, 8 dm, 2 dm
(c) 8 dm, 4 dm, 2 dm (d) 10 dm, 15 dm, 20 dm
6. The area of three adjacent faces of a cube is x, y and z. Its volume V is
(a) $V = xyz$ (b) $V^3 = xyz$ (c) $V^2 = xyz$ (d) none of these
7. Two cubes each of edge 12 cm are joined. The surface area of new cuboid is
(a) $140 cm^2$ (b) $1440 cm^2$ (c) $144 cm^2$ (d) $72 cm^2$
8. The curved surface area of cylinder of height 'h' and base radius 'r' is
(a) $2\pi rh$ (b) πrh (c) $\frac{1}{2}\pi rh$ (d) none of these
9. The total surface area of cylinder of base radius 'r' and height 'h' is
(a) $2\pi(r + h)$ (b) $2\pi r(r + h)$ (c) $3\pi r(r + h)$ (d) $4\pi r(r + h)$
10. The curved surface area of a cylinder of height 14 cm is $88 cm^2$. The diameter of its circular base is
(a) 5cm (b) 4cm (c) 3cm (d) 2cm
11. It is required to make a closed cylindrical tank of height 1 m and base diameter 140cm from a metal sheet. How many square meters a sheet are required for the same?
(a) $6.45m^2$ (b) $6.48m^2$ (c) $7.48m^2$ (d) $5.48m^2$.
12. A metal pipe is 77 cm long. Inner diameter of cross section is 4 cm and outer diameter is 4.4 cm. Its inner curved surface area is:
(a) $864 cm^2$ (b) $968 cm^2$ (c) $768 cm^2$ (d) none of these

MCQ WORKSHEET-II
CLASS X: CHAPTER – 13
SURFACE AREAS AND VOLUMES

1. The diameter of a roller is 84 cm and its length is 120 cm. It takes 500 complete revolutions to move once over to level a playground. The area of the playground in m^2 is:
(a) 1584 (b) 1284 (c) 1384 (d) 1184
 2. A cylindrical pillar is 50 cm in diameter and 3.5 m in height. The cost of painting its curved surface at the rate of Rs. 12.50 per m^2 is:
(a) Rs. 68.75 (b) Rs. 58.75 (c) Rs. 48.75 (d) Rs. 38.75
 3. The inner diameter of circular well is 3.5m. It is 10m deep. Its inner curved surface area in m^2 is:
(a) 120 (b) 110 (c) 130 (d) 140
 4. In a hot water heating system there is a cylindrical pipe of length 28 m and diameter 5 cm. The total radiating surface area in the system in m^2 is:
(a) 6.6 (b) 5.5 (c) 4.4 (d) 3.4
 5. The curved surface area of a right circular cone of slant height 10 cm and base radius 7 cm is
(a) 120 cm^2 (b) 220 cm^2 (c) 240 cm^2 (d) 140 cm^2
 6. The height of a cone is 16 cm and base radius is 12 cm. Its slant height is
(a) 10 cm (b) 15 cm (c) 20 cm (d) 8 cm
 7. The curved surface area of a right circular cone of height 16 cm and base radius 12 cm is
(a) 753.6 cm^2 (b) 1205.76 cm^2 (c) 863.8 cm^2 (d) 907.6 cm^2
 8. The curved surface area of a right circular cone of slant height 10 cm and base radius 10.5 cm is
(a) 185 cm^2 (b) 160 cm^2 (c) 165 cm^2 (d) 195 cm^2
 9. The slant height of a cone is 26 cm and base diameter is 20 cm. Its height is
(a) 24 cm (b) 25 cm (c) 23 cm (d) 35 cm
 10. The curved surface area of a cone is 308 cm^2 and its slant height is 14 cm. The radius of its base is
(a) 8 cm (b) 7 cm (c) 9 cm (d) 12 cm
 11. A conical tent is 10 m high and the radius of its base is 24 m. The slant height of tent is
(a) 26 m (b) 28 m (c) 25 m (d) 27 m
 12. The slant height and base diameter of a conical tomb are 25 m and 14 m respectively. The cost of white washing its curved surface at the rate of Rs. 210 per 100 m^2 is
(a) Rs. 1233 (b) Rs. 1155 (c) Rs. 1388 (d) Rs. 1432
-

MCQ WORKSHEET-III
CLASS X: CHAPTER – 13
SURFACE AREAS AND VOLUMES

1. A joker's cap is in the form of cone of base radius 7 cm and height 24 cm. The area of sheet to make 10 such caps is
(a) 5500 cm^2 (b) 6500 cm^2 (c) 8500 cm^2 (d) 3500 cm^2
2. A solid right cylinder cone is cut into two parts at the middle of its height by a plane parallel to its base. The ratio of the volume of the smaller cone to the whole cone is
(a) 1 : 2 (b) 1 : 4 (c) 1 : 6 (d) 1 : 8
3. The total surface area of a hemisphere of radius 'r' is
(a) $2\pi r^2$ (b) $4\pi r^2$ (c) $3\pi r^2$ (d) $5\pi r^2$
4. The curved surface area of a sphere of radius 7 cm is:
(a) 516 cm^2 (b) 616 cm^2 (c) 716 cm^2 (d) 880 cm^2
5. The curved surface area of a hemisphere of radius 21 cm is:
(a) 2772 cm^2 (b) 2564 cm^2 (c) 3772 cm^2 (d) 4772 cm^2
6. The curved surface area of a sphere of radius 14 cm is:
(a) 2464 cm^2 (b) 2428 cm^2 (c) 2464 cm^2 (d) none of these.
7. The curved surface area of a sphere of diameter 14 cm is:
(a) 516 cm^2 (b) 616 cm^2 (c) 716 cm^2 (d) 880 cm^2
8. Total surface area of hemisphere of radius 10 cm is
(a) 942 cm^2 (b) 940 cm^2 (c) 842 cm^2 (d) 840 cm^2
9. The radius of a spherical balloon increases from 7 cm to 14 cm s air is being pumped into it. The ratio of surface area of the balloon in the two cases is:
(a) 4 : 1 (b) 1 : 4 (c) 3 : 1 (d) 1 : 3
10. A matchbox measures 4 cm x 2.5 cm x 1.5 cm. The volume of packet containing 12 such boxes is:
(a) 160 cm^3 (b) 180 cm^3 (c) 160 cm^2 (d) 180 cm^2
11. A cuboidal water tank is 6 m long, 5 m wide and 4.5 m deep. How many litre of water can it hold?
(a) 1350 liters (b) 13500 liters (c) 135000 liters (d) 135 liters
12. A cuboidal vessel is 10 m long and 8 m wide. How high must it be made to hold 380 cubic metres of a liquid?
(a) 4.75 m (b) 7.85 m (c) 4.75 cm (d) none of these
13. The capacity of a cuboidal tank is 50000 litres. The length and depth are respectively 2.5 m and 10 m. Its breadth is
(a) 4 m (b) 3 m (c) 2 m (d) 5 m
14. A godown measures $40 \text{ m} \times 25 \text{ m} \times 10 \text{ m}$. Find the maximum number of wooden crates each measuring $1.5 \text{ m} \times 1.25 \text{ m} \times 0.5 \text{ m}$ that can be stored in the godown.
(a) 18000 (b) 16000 (c) 15000 (d) 14000

MCQ WORKSHEET-IV
CLASS X: CHAPTER – 13
SURFACE AREAS AND VOLUMES

1. A river 3 m deep and 40 m wide is flowing at the rate of 2 km per hour. How much water will fall into the sea in a minute?
(a) 4000 m^3 (b) 40 m^3 (c) 400 m^3 (d) 40000 m^3
 2. The circumference of the base of a cylindrical vessel is 132 cm and its height is 25 cm. How many litres of water can it hold?
(a) 33.75 litre (b) 34.65 litre (c) 35.75 litre (d) 38.75 litre
 3. If the lateral surface of a cylinder is 94.2 cm^2 and its height is 5 cm, then find radius of its base
(a) 5cm (b) 4cm (c) 3cm (d) 6cm
 4. It costs Rs 2200 to paint the inner curved surface of a cylindrical vessel 10 m deep. If the cost of painting is at the rate of Rs 20 per m^2 , find radius of the base,
(a) 1.75 m (b) 1.85 m (c) 1.95 m (d) 1.65 m
 5. The height and the slant height of a cone are 21 cm and 28 cm respectively. Find the volume of the cone.
(a) 5546 cm^3 (b) 7546 cm^3 (c) 5564 m^3 (d) 8546 cm^3
 6. Find the volume of the right circular cone with radius 6 cm, height 7 cm
(a) 254 cm^3 (b) 264 cm^3 (c) 274 cm^2 (d) 284 cm^3
 7. The radius and height of a conical vessel are 7 cm and 25 cm respectively. Its capacity in litres is
(a) 1.232 litre (b) 1.5 litre (c) 1.35 litre (d) 1.6 litre
 8. The height of a cone is 15 cm. If its volume is 1570 cm^3 , find the radius of the base.
(a) 12 cm (b) 10 cm (c) 15 cm (d) 18 cm
 9. If the volume of a right circular cone of height 9 cm is $48\pi \text{ cm}^3$, find the diameter of its base.
(a) 12 cm (b) 10 cm (c) 6 cm (d) 8 cm
 10. A conical pit of top diameter 3.5 m is 12 m deep. What is its capacity in kilolitres?
(a) 38.5 kl (b) 48.5 kl (c) 39.5 kl (d) 47.5 kl
 11. Find the capacity in litres of a conical vessel with radius 7 cm, slant height 25 cm
(a) 1.232 litre (b) 1.5 litre (c) 1.35 litre (d) none of these
 12. The diameter of the moon is approximately one-fourth of the diameter of the earth. What fraction of the volume of the earth is the volume of the moon?
(a) $\frac{1}{64}$ (b) $\frac{1}{32}$ (c) $\frac{1}{16}$ (d) $\frac{1}{48}$
 13. The dimensions of a cuboid are 50 cm x 40 cm x 10 cm. Its volume in litres is:
(a) 10 litres (b) 12 litres (c) 20 litres (d) 25 litres
 14. The volume of a cuboidal tank is 250 m^3 . If its base area is 50 m^2 then depth of the tank is
(a) 5 m (b) 200 m (c) 300 m (d) 12500 m
-

MCQ WORKSHEET-V
CLASS X: CHAPTER – 13
SURFACE AREAS AND VOLUMES

1. The length, breadth and height of a cuboidal solid is 4 cm, 3 cm and 2 cm respectively. Its volume is
(a) $(4 + 3 + 2) \text{ cm}^3$ (b) $2(4 + 3 + 2) \text{ cm}^3$ (c) $(4 \times 3 \times 2) \text{ cm}^3$ (d) $2(4 + 3) \times 2 \text{ cm}^3$
 2. The volume of a cuboidal solid of length 8 m and breadth 5 m is 200 m^3 . Find its height.
(a) 5 m (b) 6 m (c) 15 m (d) 18 m
 3. The curved surface area of a sphere is 616 cm^2 . Its radius is
(a) 7 cm (b) 5 cm (c) 6 cm (d) 8 cm
 4. If radius of a sphere is $\frac{2d}{3}$ then its volume is
(a) $\frac{32}{81} \pi d^3$ (b) $\frac{23}{4} \pi d^3$ (c) $\frac{32}{3} \pi d^3$ (d) $\frac{34}{3} \pi d^3$
 5. The capacity of a cylindrical tank is 6160 cm^3 . Its base diameter is 28 m. The depth of this tank is
(a) 5 m (b) 10 m (c) 15 m (d) 8 m
 6. The volume of a cylinder of radius r and length h is:
(a) $2\pi rh$ (b) $\frac{4}{3} \pi r^2 h$ (c) $\pi r^2 h$ (d) $2\pi r^2 h$
 7. Base radius of two cylinder are in the ratio 2 : 3 and their heights are in the ratio 5 : 3. The ratio of their volumes is
(a) 27 : 20 (b) 25 : 24 (c) 20 : 27 (d) 15 : 20
 8. If base radius and height of a cylinder are increased by 100% then its volume increased by:
(a) 30% (b) 40% (c) 42% (d) 33.1%
 9. The diameter of a sphere is 14 m. The volume of this sphere is
(a) $1437\frac{1}{3} \text{ m}^3$ (b) $1357\frac{1}{3} \text{ m}^3$ (c) $1437\frac{2}{3} \text{ m}^3$ (d) $1337\frac{2}{3} \text{ m}^3$
 10. The volume of a sphere is 524 cm^3 . The diameter of sphere is
(a) 5cm (b) 4cm (c) 3cm (d) 7cm
 11. The total surface area of a cylinder is $40\pi \text{ cm}^2$. If height is 5.5 cm then its base radius is
(a) 5cm (b) 2.5cm (c) 1.5cm (d) 10cm
 12. The area of circular base of a right circular cone is 78.5 cm^2 . If its height is 12 cm then its volume is
(a) 31.4 cm^3 (b) 3.14 cm^3 (c) 314 cm^3 (d) none of these
 13. The base radius of a cone is 11.3 cm and curved surface area is 355 cm^2 . Its height is (Take $\pi = \frac{355}{113}$)
(a) 5 cm (b) 10 cm (c) 11 cm (d) 9 cm
-

MCQ WORKSHEET-VI
CLASS X: CHAPTER – 13
SURFACE AREAS AND VOLUMES

1. If the dimensions of a cuboid are 3 cm, 4 cm and 10 cm, then its surface area is
A. 82 cm^2 B. 123 cm^2 C. 164 cm^2 D. 216 cm^2
2. The volume of the cuboid in Q.1 is
A. 17 cm^3 B. 164 cm^3 C. 120 cm^3 D. 240 cm^3
3. The surface area of a cuboid is 1372 sq. cm. If its dimensions are in the ratio of 4 : 2 : 1, then its length is
A. 7 cm B. 14 cm C. 21 cm D. 28cm
4. The base radius and height of a right circular cylinder are 7 cm and 13.5 cm. The volume of cylinder is
A. 1579 cm^3 B. 1897 cm^3 C. 2079 cm^3 D. 2197 cm^3
5. The base radius of a cone is 5 cm and its height is 12 cm. Its slant height is
A. 13 cm B. 19.5 cm C. 26 cm D. 52cm
6. The curved surface area of a cylinder of height 14 cm is 88 sq. cm. The diameter of the cylinder is
A. 0.5 cm B. 1.0 cm C. 1.5 cm D. 2.0 cm
7. The lateral surface area of a right circular cone of height 28 cm and base radius 21 cm is
A. 1155 cm^2 B. 1055 cm^2 C. 2110 cm^2 D. 2310 cm^2
8. The circumference of the base of a 8 m high conical tent is $\frac{264}{7} \text{ m}^2$. The area of canvas required to make the tent is
A. $\frac{1360}{7} \text{ cm}^2$ B. $\frac{1360}{14} \text{ cm}^2$ C. 286 cm^2 D. 98 cm^2
9. The area of metal sheet required to make a closed hollow cone of height 24 m and base radius 7 m is
A. 176 m^2 B. 352 m^2 C. 704 m^2 D. 1408 m^2
10. The diameter of a sphere whose surface area is 346.5 cm^2 is
A. 5.25 cm B. 5.75 cm C. 11.5 cm D. 10.5 cm
11. The radius of a spherical baloon increases from 7 cm to 14 cm when air is pumped into it. The ratio of the surface area of original baloon to inflated one is
A. 1 : 2 B. 1 : 3 C. 1 : 4 D. 4 : 3

12. The circumference of the base of a cylindrical vessel is 132 cm and its height is 25 cm. If 1000 cu.cm = 1 liter, the number of litres, of water the vessel can hold is
- A. 17.325 B. 34.65 C. 34.5 D. 69.30
13. The number of litres of milk a hemispherical bowl of radius 10.5 cm can hold is
- A. 2.47 B. 2.476 C. 2.376 D. 3.476
14. The number of bricks, each measuring 18 cm × 12 cm × 10 cm are required to build a wall 12 m × 0.6 m × 4.5 m if $\frac{1}{10}$ of its volume is taken by mortar, is
- A. 15000 B. 13500 C. 12500 D. 13900
15. The radius of a sphere is 10 cm. If its radius is increased by 1 cm, the volume of the sphere is increased by
- A. 13.3% B. 21.1% C. 30% D. 33.1%
-

MCQ WORKSHEET-VII
CLASS X: CHAPTER – 13
SURFACE AREAS AND VOLUMES

1. The total surface area of a solid hemisphere of radius r is
(A) πr^2 (B) $2\pi r^2$ (C) $3\pi r^2$ (D) $4\pi r^2$
 2. The volume and the surface area of a sphere are numerically equal, then the radius of sphere is
(A) 0 units (B) 1 units (C) 2 units (D) 3 units
 3. A cylinder, a cone and a hemisphere are of the same base and of the same height. The ratio of their volumes is
(A) 1 : 2 : 3 (B) 2 : 1 : 3 (C) 3 : 1 : 2 (D) 3 : 2 : 1
 4. Small spheres, each of radius 2cm, are made by melting a solid iron ball of radius 6cm, then the total number of small spheres is
(A) 9 (B) 6 (C) 27 (D) 81
 5. A solid sphere of radius r cm is melted and recast into the shape of a solid cone of height r . Then the radius of the base of cone is
(A) $2r$ (B) r (C) $4r$ (D) $3r$
 6. Three solid spheres of diameters 6cm, 8cm and 10cm are melted to form a single solid sphere. The diameter of the new sphere is
(A) 6 cm (B) 4.5 cm (C) 3 cm (D) 12 cm
 7. The radii of the ends of a frustum of a cone 40 cm high are 38 cm and 8 cm. The slant height of the frustum of cone is
(A) 50 cm (B) $10\sqrt{7}$ cm (C) 60.96 cm (D) $4\sqrt{2}$ cm
 8. The circular ends of a bucket are of radii 35 cm and 14 cm and the height of the bucket is 40 cm. Its volume is
(A) 60060 cm^3 (B) 80080 cm^3 (C) 70040 cm^3 (D) 80160 cm^3
 9. If the radii of the ends of a bucket are 5 cm and 15 cm and it is 24 cm high, then its surface area is
(A) 1815.3 cm^2 (B) 1711.3 cm^2 (C) 2025.3 cm^2 (D) 2360 cm^2
 10. If the radii of the ends of a 42 cm high bucket are 16 cm and 11 cm, determine its capacity (take $\pi = \frac{22}{7}$)
(A) 24222 cm^3 (B) 24332 cm^3 (C) 24322 cm^3 (D) none of these
-

PRACTICE QUESTIONS
CLASS X: CHAPTER – 13
SURFACE AREAS AND VOLUMES

1. A cone of maximum size is carved out from a cube of edge 14 cm. Find the surface area of the cone and of the remaining solid left out after the cone carved out.
2. A solid metallic sphere of radius 10.5 cm is melted and recast into a number of smaller cones, each of radius 3.5 cm and height 3 cm. Find the number of cones so formed.
3. A canal is 300 cm wide and 120 cm deep. The water in the canal is flowing with a speed of 20 km/h. How much area will it irrigate in 20 minutes if 8 cm of standing water is desired?
4. A cone of radius 4 cm is divided into two parts by drawing a plane through the mid point of its axis and parallel to its base. Compare the volumes of the two parts.
5. Three cubes of a metal whose edges are in the ratio 3:4:5 are melted and converted into a single cube whose diagonal is $12\sqrt{3}$ cm. Find the edges of the three cubes.
6. Three metallic solid cubes whose edges are 3 cm, 4 cm and 5 cm are melted and formed into a single cube. Find the edge of the cube so formed.
7. How many shots each having diameter 3 cm can be made from a cuboidal lead solid of dimensions $9\text{cm} \times 11\text{cm} \times 12\text{cm}$?
8. A bucket is in the form of a frustum of a cone and holds 28.490 litres of water. The radii of the top and bottom are 28 cm and 21 cm, respectively. Find the height of the bucket.
9. A cone of radius 8 cm and height 12 cm is divided into two parts by a plane through the mid-point of its axis parallel to its base. Find the ratio of the volumes of two parts.
10. Two identical cubes each of volume 64 cm^3 are joined together end to end. What is the surface area of the resulting cuboid?
11. From a solid cube of side 7 cm, a conical cavity of height 7 cm and radius 3 cm is hollowed out. Find the volume of the remaining solid.
12. Two cones with same base radius 8 cm and height 15 cm are joined together along their bases. Find the surface area of the shape so formed.
13. Two solid cones A and B are placed in a cylindrical tube as shown in the below figure. The ratio of their capacities is 2:1. Find the heights and capacities of cones. Also, find the volume of the remaining portion of the cylinder.

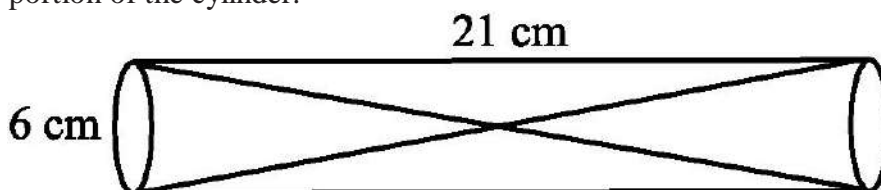

14. An ice cream cone full of ice cream having radius 5 cm and height 10 cm as shown in the below figure. Calculate the volume of ice cream, provided that its $\frac{1}{6}$ part is left unfilled with ice cream.

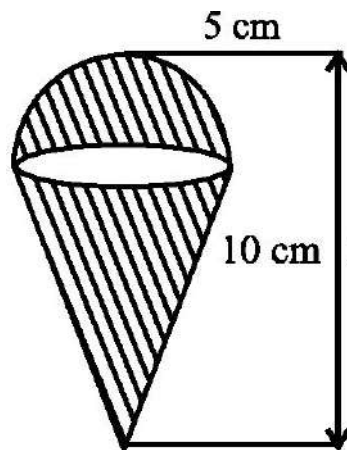

15. Marbles of diameter 1.4 cm are dropped into a cylindrical beaker of diameter 7 cm containing some water. Find the number of marbles that should be dropped into the beaker so that the water level rises by 5.6 cm.
16. How many spherical lead shots each of diameter 4.2 cm can be obtained from a solid rectangular lead piece with dimensions 66 cm, 42 cm and 21 cm.
17. How many spherical lead shots of diameter 4 cm can be made out of a solid cube of lead whose edge measures 44 cm.
18. A wall 24 m long, 0.4 m thick and 6 m high is constructed with the bricks each of dimensions 25 cm \times 16 cm \times 10 cm. If the mortar occupies $\frac{1}{10}$ th of the volume of the wall, then find the number of bricks used in constructing the wall.
19. Find the number of metallic circular disc with 1.5 cm base diameter and of height 0.2 cm to be melted to form a right circular cylinder of height 10 cm and diameter 4.5 cm.
20. A bucket is in the form of a frustum of a cone of height 30 cm with radii of its lower and upper ends as 10 cm and 20 cm, respectively. Find the capacity and surface area of the bucket. Also, find the cost of milk which can completely fill the container, at the rate of Rs 25 per litre (use $\pi = 3.14$).
21. A solid toy is in the form of a hemisphere surmounted by a right circular cone. The height of the cone is 4 cm and the diameter of the base is 8 cm. Determine the volume of the toy. If a cube circumscribes the toy, then find the difference of the volumes of cube and the toy. Also, find the total surface area of the toy.
22. A solid metallic hemisphere of radius 8 cm is melted and recasted into a right circular cone of base radius 6 cm. Determine the height of the cone.
23. A rectangular water tank of base 11 m \times 6 m contains water upto a height of 5 m. If the water in the tank is transferred to a cylindrical tank of radius 3.5 m, find the height of the water level in the tank.

24. A building is in the form of a cylinder surmounted by a hemispherical dome. The base diameter of the dome is equal to $\frac{2}{3}$ of the total height of the building. Find the height of the building, if it contains $67\frac{1}{21}$ m³ of air.
25. How many cubic centimetres of iron is required to construct an open box whose external dimensions are 36 cm, 25 cm and 16.5 cm provided the thickness of the iron is 1.5 cm. If one cubic cm of iron weighs 7.5 g, find the weight of the box.
26. The barrel of a fountain pen, cylindrical in shape, is 7 cm long and 5 mm in diameter. A full barrel of ink in the pen is used up on writing 3300 words on an average. How many words can be written in a bottle of ink containing one fifth of a litre?
27. Water flows at the rate of 10m/minute through a cylindrical pipe 5 mm in diameter. How long would it take to fill a conical vessel whose diameter at the base is 40 cm and depth 24 cm?
28. A heap of rice is in the form of a cone of diameter 9 m and height 3.5 m. Find the volume of the rice. How much canvas cloth is required to just cover the heap?
29. A factory manufactures 120000 pencils daily. The pencils are cylindrical in shape each of length 25 cm and circumference of base as 1.5 cm. Determine the cost of colouring the curved surfaces of the pencils manufactured in one day at Rs 0.05 per dm².
30. Water is flowing at the rate of 15 km/h through a pipe of diameter 14 cm into a cuboidal pond which is 50 m long and 44 m wide. In what time will the level of water in pond rise by 21 cm?
31. A solid iron cuboidal block of dimensions 4.4 m × 2.6 m × 1m is recast into a hollow cylindrical pipe of internal radius 30 cm and thickness 5 cm. Find the length of the pipe.
32. 500 persons are taking a dip into a cuboidal pond which is 80 m long and 50 m broad. What is the rise of water level in the pond, if the average displacement of the water by a person is 0.04m³?
33. 16 glass spheres each of radius 2 cm are packed into a cuboidal box of internal dimensions 16 cm × 8 cm × 8 cm and then the box is filled with water. Find the volume of water filled in the box.
34. A milk container of height 16 cm is made of metal sheet in the form of a frustum of a cone with radii of its lower and upper ends as 8 cm and 20 cm respectively. Find the cost of milk at the rate of Rs. 22 per litre which the container can hold.
35. A cylindrical bucket of height 32 cm and base radius 18 cm is filled with sand. This bucket is emptied on the ground and a conical heap of sand is formed. If the height of the conical heap is 24 cm, find the radius and slant height of the heap.
36. A rocket is in the form of a right circular cylinder closed at the lower end and surmounted by a cone with the same radius as that of the cylinder. The diameter and height of the cylinder are 6 cm and 12 cm, respectively. If the slant height of the conical portion is 5 cm, find the total surface area and volume of the rocket [Use $\pi = 3.14$].

37. A building is in the form a cylinder surmounted by a hemispherical vaulted dome and contains $41\frac{19}{21}$ m³ of air. If the internal diameter of dome is equal to its total height above the floor, find the height of the building?
38. A hemispherical bowl of internal radius 9 cm is full of liquid. The liquid is to be filled into cylindrical shaped bottles each of radius 1.5 cm and height 4 cm. How many bottles are needed to empty the bowl?
39. A solid right circular cone of height 120 cm and radius 60 cm is placed in a right circular cylinder full of water of height 180 cm such that it touches the bottom. Find the volume of water left in the cylinder, if the radius of the cylinder is equal to the radius of the cone.
40. Water flows through a cylindrical pipe, whose inner radius is 1 cm, at the rate of 80 cm/sec in an empty cylindrical tank, the radius of whose base is 40 cm. What is the rise of water level in tank in half an hour?
41. The rain water from a roof of dimensions 22 m 20 m drains into a cylindrical vessel having diameter of base 2 m and height 3.5 m. If the rain water collected from the roof just fill the cylindrical vessel, then find the rainfall in cm.
42. A pen stand made of wood is in the shape of a cuboid with four conical depressions and a cubical depression to hold the pens and pins, respectively. The dimension of the cuboid are 10 cm, 5 cm and 4 cm. The radius of each of the conical depressions is 0.5 cm and the depth is 2.1 cm. The edge of the cubical depression is 3 cm. Find the volume of the wood in the entire stand.
43. A cone of radius 10cm is divided into two parts by drawing a plane through the midpoint of its axis, parallel to its base. Compare the volume of the two parts.
44. A hollow cone is cut by a plane parallel to the base and the upper portion is removed. If the curved surface of the remainder is $\frac{8}{9}$ of the curved surface of the whole cone. Find the ratio of the line segments into which the cone's altitude is divided by the plane.
45. From a solid cylinder of height 24cm and diameter 10cm, two conical cavities of same radius as that of the cylinder are hollowed out. If the height of each conical activity is half the height of cylinder, find the total surface area of the remaining cylinder.
46. A farmer connects a pipe of internal diameter 20cm from a canal into a cylindrical tank to her field, which is 10m in diameter and 2m deep. If water flows through the pipe at the rate of 3km/hr, in how much time will the tank be filled?
47. A toy is in the form of a cone on a hemi-sphere of diameter 7 cm. The total height of the top is 14.5cm. Find the volume and total surface area of the toy.
48. A vessel in the form of hemi-spherical is mounted by a hollow cylinder. The diameter of the bowl is 14cm and the total height of the vessel is 13 cm. Find the capacity of the vessel.
49. A cylindrical with radius and height is 4cm and 8cm is filled with Ice-cream and ice-cream is distributed to 10 Children in equal can having hemi-spherical tops. If the height of the conical portion is 4 times the radius of its base, find the radius of the ice-cream cone.

50. A tent has cylindrical surmounted by a conical roof. The radius of the cylindrical base is 20m. The total height of tent is 6.3m and height of cylindrical portion is 4.2m, find the volume and surface area of tent.
51. Rasheed got a playing top (*lattu*) as his birthday present, which surprisingly had no colour on it. He wanted to colour it with his crayons. The top is shaped like a cone surmounted by a hemisphere. The entire top is 5 cm in height and the diameter of the top is 3.5 cm. Find the area he has to colour. (Take $\pi = 22/7$)
52. A wooden toy rocket is in the shape of a cone mounted on a cylinder. The height of the entire rocket is 26 cm, while the height of the conical part is 6 cm. The base of the conical portion has a diameter of 5 cm, while the base diameter of the cylindrical portion is 3 cm. If the conical portion is to be painted orange and the cylindrical portion yellow, find the area of the rocket painted with each of these colours. (Take $\pi = 3.14$)
53. A toy is in the form of a cone of radius 3.5 cm mounted on a hemisphere of same radius. The total height of the toy is 15.5 cm. Find the total surface area of the toy.
54. A tent is in the shape of a cylinder surmounted by a conical top. If the height and diameter of the cylindrical part are 2.1 m and 4 m respectively, and the slant height of the top is 2.8 m, find the area of the canvas used for making the tent. Also, find the cost of the canvas of the tent at the rate of Rs 500 per m^2
55. From a solid cylinder whose height is 2.4 cm and diameter 1.4 cm, a conical cavity of the same height and same diameter is hollowed out. Find the total surface area of the remaining solid to the nearest cm^2 .
56. A juice seller was serving his customers using glasses. The inner diameter of the cylindrical glass was 5 cm, but the bottom of the glass had a hemispherical raised portion which reduced the capacity of the glass. If the height of a glass was 10 cm, find the apparent capacity of the glass and its actual capacity. (Take $\pi = 3.14$)
57. A solid toy is in the form of a hemisphere surmounted by a right circular cone. The height of the cone is 2 cm and the diameter of the base is 4 cm. Determine the volume of the toy. If a right circular cylinder circumscribes the toy, find the difference of the volumes of the cylinder and the toy. (Take $\pi = 3.14$)
58. A *gulab jamun*, contains sugar syrup up to about 30% of its volume. Find approximately how much syrup would be found in 45 *gulab jamuns*, each shaped like a cylinder with two hemispherical ends with length 5 cm and diameter 2.8 cm.
59. A pen stand made of wood is in the shape of a cuboid with four conical depressions to hold pens. The dimensions of the cuboid are 15 cm by 10 cm by 3.5 cm. The radius of each of the depressions is 0.5 cm and the depth is 1.4 cm. Find the volume of wood in the entire stand.
60. A vessel is in the form of an inverted cone. Its height is 8 cm and the radius of its top, which is open, is 5 cm. It is filled with water up to the brim. When lead shots, each of which is a sphere of radius 0.5 cm are dropped into the vessel, one-fourth of the water flows out. Find the number of lead shots dropped in the vessel.
61. A solid iron pole consists of a cylinder of height 220 cm and base diameter 24 cm, which is surmounted by another cylinder of height 60 cm and radius 8 cm. Find the mass of the pole, given that 1 cm^3 of iron has approximately 8g mass. (Use $\pi = 3.14$)

62. A solid consisting of a right circular cone of height 120 cm and radius 60 cm standing on a hemisphere of radius 60 cm is placed upright in a right circular cylinder full of water such that it touches the bottom. Find the volume of water left in the cylinder, if the radius of the cylinder is 60 cm and its height is 180 cm.
63. A spherical glass vessel has a cylindrical neck 8 cm long, 2 cm in diameter; the diameter of the spherical part is 8.5 cm. By measuring the amount of water it holds, a child finds its volume to be 345 cm³. Check whether she is correct, taking the above as the inside measurements, and $\pi = 3.14$.
64. A cone of height 24 cm and radius of base 6 cm is made up of modeling clay. A child reshapes it in the form of a sphere. Find the radius of the sphere.
65. Selvi's house has an overhead tank in the shape of a cylinder. This is filled by pumping water from a sump (an underground tank) which is in the shape of a cuboid. The sump has dimensions 1.57 m \times 1.44 m \times 95cm. The overhead tank has its radius 60 cm and height 95 cm. Find the height of the water left in the sump after the overhead tank has been completely filled with water from the sump which had been full. Compare the capacity of the tank with that of the sump. (Use $\pi = 3.14$)
66. A copper rod of diameter 1 cm and length 8 cm is drawn into a wire of length 18 m of uniform thickness. Find the thickness of the wire.
67. A hemispherical tank full of water is emptied by a pipe at the rate of $3\frac{4}{7}$ litres per second. How much time will it take to empty half the tank, if it is 3m in diameter? (Take $\pi = 22/7$)
68. A 20 m deep well with diameter 7 m is dug and the earth from digging is evenly spread out to form a platform 22 m by 14 m. Find the height of the platform.
69. A well of diameter 3 m is dug 14 m deep. The earth taken out of it has been spread evenly all around it in the shape of a circular ring of width 4 m to form an embankment. Find the height of the embankment.
70. A container shaped like a right circular cylinder having diameter 12 cm and height 15 cm is full of ice cream. The ice cream is to be filled into cones of height 12 cm and diameter 6 cm, having a hemispherical shape on the top. Find the number of such cones which can be filled with ice cream.
71. How many silver coins, 1.75 cm in diameter and of thickness 2 mm, must be melted to form a cuboid of dimensions 5.5 cm \times 10 cm \times 3.5 cm?
72. A cylindrical bucket, 32 cm high and with radius of base 18 cm, is filled with sand. This bucket is emptied on the ground and a conical heap of sand is formed. If the height of the conical heap is 24 cm, find the radius and slant height of the heap.
73. Water in a canal, 6 m wide and 1.5 m deep, is flowing with a speed of 10 km/h. How much area will it irrigate in 30 minutes, if 8 cm of standing water is needed?
74. A farmer connects a pipe of internal diameter 20 cm from a canal into a cylindrical tank in her field, which is 10 m in diameter and 2 m deep. If water flows through the pipe at the rate of 3 km/h, in how much time will the tank be filled?

75. Hanumappa and his wife Gangamma are busy making jaggery out of sugarcane juice. They have processed the sugarcane juice to make the molasses, which is poured into moulds in the shape of a frustum of a cone having the diameters of its two circular faces as 30 cm and 35 cm and the vertical height of the mould is 14 cm. If each cm^3 of molasses has mass about 1.2 g, find the mass of the molasses that can be poured into each mould. (Take $\pi = 22/7$)
76. An open metal bucket is in the shape of a frustum of a cone, mounted on a hollow cylindrical base made of the same metallic sheet. The diameters of the two circular ends of the bucket are 45 cm and 25 cm, the total vertical height of the bucket is 40 cm and that of the cylindrical base is 6 cm. Find the area of the metallic sheet used to make the bucket, where we do not take into account the handle of the bucket. Also, find the volume of water the bucket can hold.
77. A container, opened from the top and made up of a metal sheet, is in the form of a frustum of a cone of height 16 cm with radii of its lower and upper ends as 8 cm and 20 cm, respectively. Find the cost of the milk which can completely fill the container, at the rate of Rs 20 per litre. Also find the cost of metal sheet used to make the container, if it costs Rs 8 per 100 cm^2 . (Take $\pi = 3.14$)
78. A metallic right circular cone 20 cm high and whose vertical angle is 60° is cut into two parts at the middle of its height by a plane parallel to its base. If the frustum so obtained be drawn into a wire of diameter $\frac{1}{16}$ cm, find the length of the wire.
79. A right triangle, whose sides are 3 cm and 4 cm (other than hypotenuse) is made to revolve about its hypotenuse. Find the volume and surface area of the double cone so formed.
80. The decorative block shown in Fig. is made of two solids - a cube and a hemisphere. The base of the block is a cube with edge 5 cm, and the hemisphere fixed on the top has a diameter of 4.2 cm. Find the total surface area of the block. (Take $\pi = 22/7$).

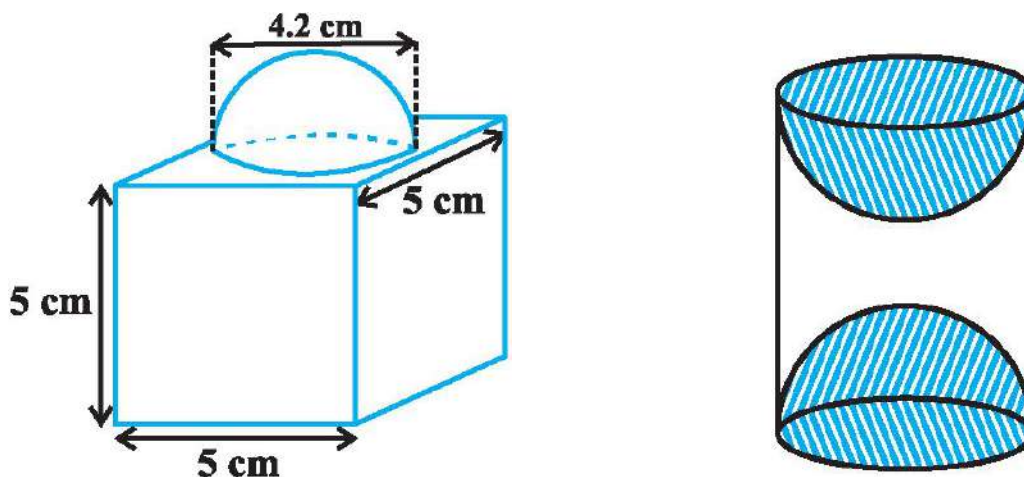

81. A wooden article was made by scooping out a hemisphere from each end of a solid cylinder, as shown in above Fig.. If the height of the cylinder is 10 cm, and its base is of radius 3.5 cm, find the total surface area of the article.
82. A sphere of diameter 12 cm, is dropped in a right circular cylindrical vessel, partly filled with water. If the sphere is completely submerged in water level in the cylindrical vessel rises by $3\frac{5}{9}$ cm. find the diameter of the cylindrical vessel.
83. An iron pillar has lower part in the form of a right circular cylinder and the upper part is in the form of a right circular cone. The radius of the base of the cone and cylinder is 8cm. The cylindrical part is 240cm high and the conical part is 36cm high. Find the weight of the pillar if 1 cm^3 of iron weighs 7.5 grams.

84. An oil funnel made of tin sheet consists of a 10 cm long cylindrical portion attached to a frustum of a cone. If the total height is 22 cm, diameter of the cylindrical portion is 8 cm and the diameter of the top of the funnel is 18 cm, find the area of the tin sheet required to make the funnel (see below figure)

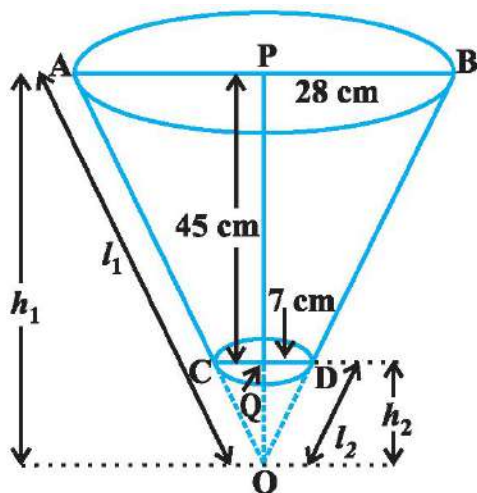
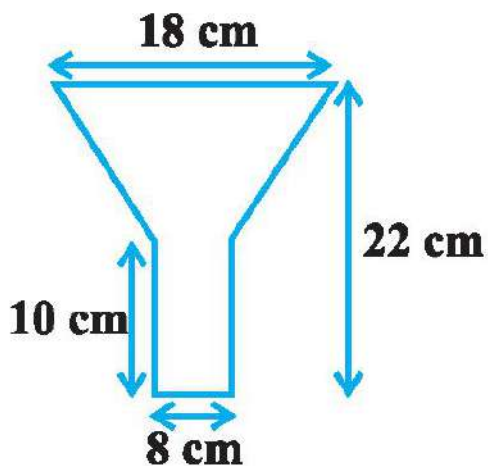

85. The radii of the ends of a frustum of a cone 45 cm high are 28 cm and 7 cm (see above sided Fig). Find its volume, the curved surface area and the total surface area. (Take $\pi = 22/7$)

CLASS X: CHAPTER - 14
STATISTICS

IMPORTANT FORMULAS & CONCEPTS

In many real-life situations, it is helpful to describe data by a single number that is most representative of the entire collection of numbers. Such a number is called a **measure of central tendency**. The most commonly used measures are as follows.

1. The **mean**, or **average**, of 'n' numbers is the sum of the numbers divided by n.
2. The **median** of 'n' numbers is the middle number when the numbers are written in order. If n is even, the median is the average of the two middle numbers.
3. The **mode** of 'n' numbers is the number that occurs most frequently. If two numbers tie for most frequent occurrence, the collection has two modes and is called **bimodal**.

MEAN OF GROUPED DATA

Direct method

$$\text{Mean, } \bar{x} = \frac{\sum f_i x_i}{\sum f_i}$$

Assume mean method or Short-cut method

$$\text{Mean, } \bar{x} = A + \frac{\sum f_i d_i}{\sum f_i} \text{ where } d_i = x_i - A$$

Step Deviation method

$$\text{Mean, } \bar{x} = A + \frac{\sum f_i u_i}{\sum f_i} \times h \text{ where } u = \frac{x_i - A}{h}$$

MODE OF GROUPED DATA

$$\text{Mode} = l + \left(\frac{f_1 - f_0}{2f_1 - f_0 - f_2} \right) \times h$$

where l = lower limit of the modal class,

h = size of the class interval (assuming all class sizes to be equal),

f_1 = frequency of the modal class,

f_0 = frequency of the class preceding the modal class,

f_2 = frequency of the class succeeding the modal class.

- **Cumulative Frequency:** The cumulative frequency of a class is the frequency obtained by adding the frequencies of all the classes preceding the given class.

MEDIAN OF GROUPED DATA

$$\text{Median} = l + \left(\frac{\frac{n}{2} - cf}{f} \right) \times h$$

where l = lower limit of median class,

n = number of observations,

cf = cumulative frequency of class preceding the median class,

f = frequency of median class,

h = class size (assuming class size to be equal).

EMPIRICAL FORMULA

$$3\text{Median} = \text{Mode} + 2 \text{ Mean}$$

❖ Cumulative frequency curve is also known as 'Ogive'.

There are three methods of drawing ogive:

1. LESS THAN METHOD

Steps involved in calculating median using less than Ogive approach-

- Convert the series into a 'less than' cumulative frequency distribution.
- Let N be the total number of students whose data is given. N will also be the cumulative frequency of the last interval. Find the $(N/2)^{\text{th}}$ item and mark it on the y-axis.
- Draw a perpendicular from that point to the right to cut the Ogive curve at point A.
- From point A where the Ogive curve is cut, draw a perpendicular on the x-axis. The point at which it touches the x-axis will be the median value of the series as shown in the graph.

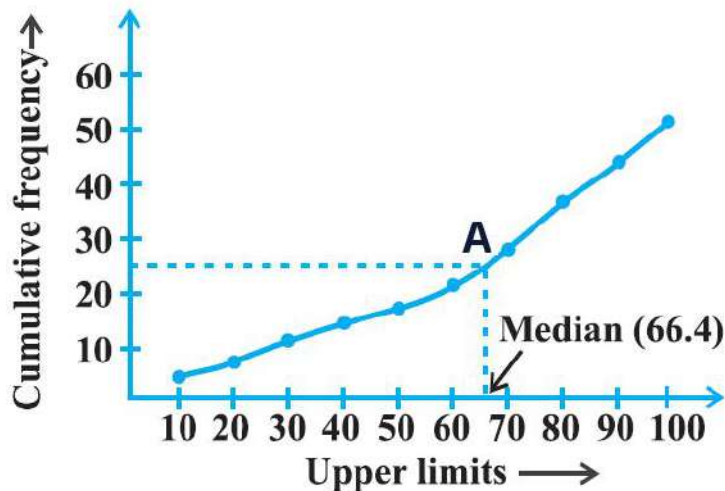

2. MORE THAN METHOD

Steps involved in calculating median using more than Ogive approach-

- Convert the series into a 'more than' cumulative frequency distribution.
- Let N be the total number of students whose data is given. N will also be the cumulative frequency of the last interval. Find the $(N/2)^{\text{th}}$ item and mark it on the y-axis.
- Draw a perpendicular from that point to the right to cut the Ogive curve at point A.
- From point A where the Ogive curve is cut, draw a perpendicular on the x-axis. The point at which it touches the x-axis will be the median value of the series as shown in the graph.

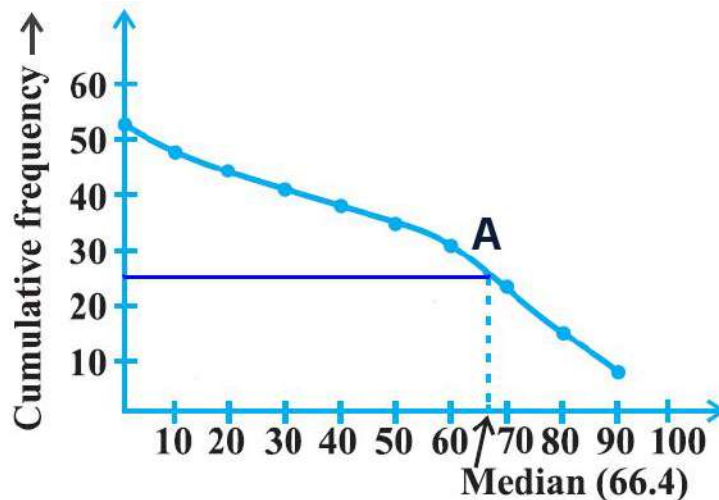

3. LESS THAN AND MORE THAN OGIVE METHOD

Another way of graphical determination of median is through simultaneous graphic presentation of both the less than and more than Ogives.

- Mark the point A where the Ogive curves cut each other.
- Draw a perpendicular from A on the x-axis. The corresponding value on the x-axis would be the median value.

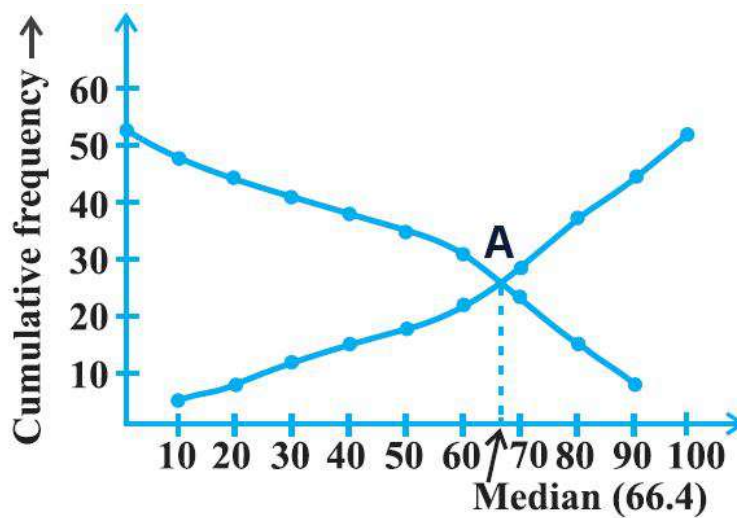

- ❖ The median of grouped data can be obtained graphically as the x -coordinate of the point of intersection of the two ogives for this data.

MCQ WORKSHEET-I
CLASS X: CHAPTER - 14
STATISTICS

- For a frequency distribution, mean, median and mode are connected by the relation
(a) mode = 3mean – 2median (b) mode = 2median – 3mean
(c) mode = 3median – 2mean (d) mode = 3median + 2mean
- Which measure of central tendency is given by the x – coordinate of the point of intersection of the more than ogive and less than ogive?
(a) mode (b) median (c) mean (d) all the above three measures
- The class mark of a class interval is
(a) upper limit + lower limit (b) upper limit – lower limit
(c) $\frac{1}{2}$ (upper limit + lower limit) (d) $\frac{1}{2}$ (upper limit – lower limit)
- Construction of cumulative frequency table is useful in determining the
(a) mode (b) median (c) mean (d) all the above three measures
- For the following distribution

Marks	Number of students
Below 10	3
Below 20	12
Below 30	27
Below 40	57
Below 50	75
Below 60	80

the modal class is

- (a) 10 – 20 (b) 20 – 30 (c) 30 – 40 (d) 40 – 50
- For the following distribution

Marks	Number of students
Below 10	3
Below 20	12
Below 30	27
Below 40	57
Below 50	75
Below 60	80

the median class is

- (a) 10 – 20 (b) 20 – 30 (c) 30 – 40 (d) 40 – 50
- In a continuous frequency distribution, the median of the data is 24. If each item is increased by 2, then the new median will be
(a) 24 (b) 26 (c) 12 (d) 48
 - In a grouped frequency distribution, the mid values of the classes are used to measure which of the following central tendency?
(a) mode (b) median (c) mean (d) all the above three measures
 - Which of the following is not a measure of central tendency of a statistical data?
(a) mode (b) median (c) mean (d) range
 - Weights of 40 eggs were recorded as given below:

Weights(in gms)	85 – 89	90 – 94	95 – 99	100 – 104	105- 109
No. of eggs	10	12	12	4	2

The lower limit of the median class is

- (a) 90 (b) 95 (c) 94.5 (d) 89.5

MCQ WORKSHEET-II
CLASS X: CHAPTER - 14
STATISTICS

1. The median class of the following distribution is

C.I	0 – 10	10 – 20	20 – 30	30 – 40	40 – 50	50 – 60
F	8	10	12	22	30	18

- (a) 10 – 20 (b) 20 – 30 (c) 30 – 40 (d) 40 – 50

2. Weights of 40 eggs were recorded as given below:

Weights(in gms)	85 – 89	90 – 94	95 – 99	100 – 104	105- 109
No. of eggs	10	12	15	4	2

The lower limit of the modal class is

- (a) 90 (b) 95 (c) 94.5 (d) 89.5

3. The arithmetic mean of 12 observations is 7.5. If the arithmetic mean of 7 of these observations is 6.5, the mean of the remaining observations is

- (a) 5.5 (b) 8.5 (c) 8.9 (d) 9.2

4. In a continuous frequency distribution, the mean of the data is 25. If each item is increased by 5, then the new median will be

- (a) 25 (b) 30 (c) 20 (d) none of these

5. In a continuous frequency distribution with usual notations, if $l = 32.5$, $f_1 = 15$, $f_0 = 12$, $f_2 = 8$ and $h = 8$, then the mode of the data is

- (a) 32.5 (b) 33.5 (c) 33.9 (d) 34.9

6. The arithmetic mean of the following frequency distribution is 25, then the value of p is

C.I	0 – 10	10 – 20	20 – 30	30 – 40	40 – 50
F	5	18	15	p	6

- (a) 12 (b) 16 (c) 18 (d) 20

7. If the mean of the following frequency distribution is 54, then the value of p is

C.I	0 – 20	20 – 40	40 – 60	60 – 80	80 – 100
F	7	p	10	9	13

- (a) 12 (b) 16 (c) 18 (d) 11

8. The mean of the following frequency distribution is

C.I	0 – 10	10 – 20	20 – 30	30 – 40	40 – 50
F	12	16	6	7	9

- (a) 12 (b) 16 (c) 22 (d) 20

9. The mean of the following frequency distribution is

C.I	0 – 10	10 – 20	20 – 30	30 – 40	40 – 50
F	7	8	12	13	10

- (a) 12.2 (b) 16.2 (c) 22.2 (d) 27.2

10. The median of the following frequency distribution is

C.I	100 – 150	150 – 200	200 – 250	250 – 300	300 – 350
F	6	3	5	20	10

- (a) 120 (b) 160 (c) 220 (d) 270

MCQ WORKSHEET-III
CLASS X: CHAPTER - 14
STATISTICS

1. The range of the data 14, 27, 29, 61, 45, 15, 9, 18 is
(a) 61 (b) 52 (c) 47 (d) 53
2. The class mark of the class 120 – 150 is
(a) 120 (b) 130 (c) 135 (d) 150
3. The class mark of a class is 10 and its class width is 6. The lower limit of the class is
(a) 5 (b) 7 (c) 8 (d) 10
4. In a frequency distribution, the class width is 4 and the lower limit of first class is 10. If there are six classes, the upper limit of last class is
(a) 22 (b) 26 (c) 30 (d) 34
5. The class marks of a distribution are 15, 20, 25,.....45. The class corresponding to 45 is
(a) 12.5 – 17.5 (b) 22.5 – 27.5 (c) 42.5 – 47.5 (d) none of these
6. The number of students in which two classes are equal.
(a) VI and VIII (b) VI and VII (c) VII and VIII (d) none of these

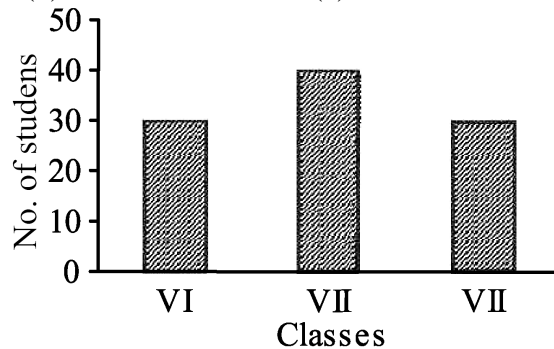

7. The mean of first five prime numbers is
(a) 5.0 (b) 4.5 (c) 5.6 (d) 6.5
8. The mean of first ten multiples of 7 is
(a) 35.0 (b) 36.5 (c) 38.5 (d) 39.2
9. The mean of $x + 3$, $x - 2$, $x + 5$, $x + 7$ and $x + 72$ is
(a) $x + 5$ (b) $x + 2$ (c) $x + 3$ (d) $x + 7$
10. If the mean of n observations $x_1, x_2, x_3, \dots, x_n$ is \bar{x} then $\sum_{i=1}^n x_i - \bar{x}$ is
(a) 1 (b) -1 (c) 0 (d) cannot be found
11. The mean of 10 observations is 42. If each observation in the data is decreased by 12, the new mean of the data is
(a) 12 (b) 15 (c) 30 (d) 54
12. The median of 10, 12, 14, 16, 18, 20 is
(a) 12 (b) 14 (c) 15 (d) 16

13. If the median of 12, 13, 16, $x + 2$, $x + 4$, 28, 30, 32 is 23, when $x + 2$, $x + 4$ lie between 16 and 30, then the value of x is

- (a) 18 (b) 19 (c) 20 (d) 22

14. If the mode of 12, 16, 19, 16, x , 12, 16, 19, 12 is 16, then the value of x is

- (a) 12 (b) 16 (c) 19 (d) 18

15. The mean of the following data is

x	5	10	15	20	25
f	3	5	8	3	1

- (a) 12 (b) 13 (c) 13.5 (d) 13.6

16. The mean of 10 numbers is 15 and that of another 20 number is 24 then the mean of all 30 observations is

- (a) 20 (b) 15 (c) 21 (d) 24



MCQ WORKSHEET-IV
CLASS X: CHAPTER - 14
STATISTICS

- Construction of cumulative frequency table is useful in determining the
(a) mean (b) median (c) mode (d) all three
- In the formula $\bar{x} = a + \frac{\sum f_i d_i}{\sum f_i}$, finding the mean of the grouped data, d_i 's are deviations from assumed mean 'a' of
(a) lower limits of classes (b) upper limits of classes
(c) class marks (d) frequencies of the classes.
- If x_i 's are the midpoints of the class intervals of grouped data, f_i 's are the corresponding frequencies and \bar{x} is the mean, then $\sum f_i (x_i - \bar{x})$ is equal to
(a) 0 (b) -1 (c) 1 (d) 2
- In the formula $\bar{x} = a + \left(\frac{\sum f_i u_i}{\sum f_i} \times h \right)$, finding the mean of the grouped data, $u_i =$
(a) $\frac{x_i + a}{h}$ (b) $\frac{x_i - a}{h}$ (c) $\frac{a - x_i}{h}$ (d) $h(x_i - a)$
- For the following distribution:

Class	0-5	5-10	10-15	15-20	20-25
Frequency	10	15	12	20	9

The sum of lower limits of the median class and the modal class is
(a) 15 (b) 25 (c) 30 (d) 35

- Consider the following frequency distribution:

Class	0-9	10-19	20-29	30-39	40-49
Frequency	13	10	15	8	11

The upper limit of the median class is
(a) 29 (b) 29.5 (c) 30 (d) 19.5

- The abscissa of the point of intersection of the less than type and of the more than type ogives gives its
(a) mean (b) median (c) mode (d) all three

- For the following distribution: the modal class is

Marks	Below 10	Below 20	Below 30	Below 40	Below 50
No. of Students	8	17	32	62	80

(a) 10 – 20 (b) 20 – 30 (c) 30 – 40 (d) 40 – 50

- From the following data of the marks obtained by students of class X

Marks	0-10	10-20	20-30	30-40	40-50	50-60
No. of Students	8	12	20	30	10	10

How many students, secured less than 40 marks?

(a) 70 (b) 40 (c) 80 (d) 30

10. The times in seconds taken by 150 athletics to run a 100m hurdle race are given as under:

Class	12.7-13	13-13.3	13.3-13.6	13.6-13.9	13.9-13.12
Frequency	5	6	10	55	41

The number of athletes who completed the race in less than 13.9 sec is

- (a) 21 (b) 55 (c) 41 (d) 76

11. Consider the data:

Class	25-45	45-65	65-85	85-105	105-125	125-145
Frequency	4	5	12	20	14	11

The difference of the upper limit of the median class and the lower limit of the modal class is

- (a) 0 (b) 19 (c) 20 (d) 38

12. Consider the following distribution:

Marks	Above 0	Above 10	Above 20	Above 30	Above 40	Above 50
No. of Students	63	58	55	51	48	42

The frequency of the class 30 – 40 is

- (a) 3 (b) 4 (c) 48 (d) 41



PRACTICE QUESTIONS
CLASS X: CHAPTER - 14
STATISTICS
MEAN BASED QUESTIONS

1. Is it true to say that the mean, mode and median of grouped data will always be different. Justify your answer.
2. The mean of ungrouped data and the mean calculated when the same data is grouped are always the same. Do you agree with this statement? Give reason for your answer.

3. Find the mean of the distribution:

Class	1-3	3-5	5-7	7-9
Frequency	9	22	27	17

4. Daily wages of 110 workers, obtained in a survey, are tabulated below:

Daily wages (in Rs.)	100 - 120	120 - 140	140 - 160	160 - 180	180 - 200	200 - 220
No. of workers	15	18	25	22	18	12

Determine the mean wages of workers.

5. Calculate the mean of the scores of 20 students in a mathematics test :

Marks	0-10	10-20	20-30	30-40	40-50
No. of Students	2	4	7	6	1

6. Calculate the mean of the following data :

Class	4-7	8-11	12-15	16-19
Frequency	5	4	9	10

7. The following table gives the number of pages written by Sarika for completing her own book for 30 days :

No. of pages written per day	16-18	19-21	22-24	25-27	28-30
No. of days	1	3	4	9	13

Find the mean number of pages written per day.

8. The daily income of a sample of 50 employees are tabulated as follows :

Income(in Rs.)	1-200	201-400	401-600	601-800
No. of employees	14	15	14	7

9. The weights (in kg) of 50 wrestlers are recorded in the following table :

Weight(in kg)	100-110	110-120	120-130	130-140	140-150
No. of wrestlers	4	14	21	8	3

Find the mean weight of the wrestlers.

10. An aircraft has 120 passenger seats. The number of seats occupied during 100 flights is given below:

No. of seats	100-104	104-108	108-112	112-116	116-120
Frequency	15	20	32	18	15

Determine the mean number of seats occupied over the flights

11. The mileage (km per litre) of 50 cars of the same model was tested by a manufacturer and details are tabulated as given below :

Mileage(km/l)	10-12	12-14	14-16	16-18
No. of cars	7	12	18	13

Find the mean mileage. The manufacturer claimed that the mileage of the model was 16 km/litre. Do you agree with this claim?

12. The following table shows the cumulative frequency distribution of marks of 800 students in an examination:

Marks	Below 10	Below 20	Below 30	Below 40	Below 50	Below 60	Below 70	Below 80	Below 90	Below 100
No. of Students	8	17	32	62	80	80	80	80	80	80

Find the mean marks.

13. The following is the cumulative frequency distribution (of less than type) of 1000 persons each of age 20 years and above. Determine the mean age.

Age Below(in years)	30	40	50	60	70	80
No. of persons	100	220	350	750	950	1000

14. Find the mean marks of students for the following distribution :

Marks Above	0	10	20	30	40	50	60	70	80	90	100
No. of Students	80	77	72	65	55	43	28	16	10	8	0

15. Determine the mean of the following distribution :

Marks Below	10	20	30	40	50	60	70	80	90	100
No. of Students	5	9	17	29	45	60	70	78	83	85

16. Find the mean age of 100 residents of a town from the following data :

Age equal and above(in years)	0	10	20	30	40	50	60	70
No. of Persons	100	90	75	50	25	15	5	0

17. Find the mean weights of tea in 70 packets shown in the following table :

Weight(in gm)	200-201	201-202	202-203	203-204	204-205	205-206
No. of packets	13	27	18	10	1	1

18. Find the mean of the following distribution :

Class	0-20	20-40	40-60	60-80	80-100	100-120	120-140
Frequency	12	18	15	25	26	15	9

19. Find the mean age from the following distribution :

Age(in years)	25-29	30-34	35-39	40-44	45-49	50-54	55-59
No. of persons	4	14	22	16	6	5	3

20. Find the mean age of the patients from the following distribution :

Age(in years)	5-14	15-24	25-34	35-44	45-54	55-64
No. of patients	6	11	21	23	14	5

.....

PRACTICE QUESTIONS
CLASS X: CHAPTER - 14
STATISTICS
MEDIAN BASED QUESTIONS

1. The median of an ungrouped data and the median calculated when the same data is grouped are always the same. Do you think that this is a correct statement? Give Reason.

2. The percentage of marks obtained by 100 students in an examination are given below:

Marks	30-35	35-40	40-45	45-50	50-55	55-60	60-65
No. of Students	14	16	18	23	18	8	3

Determine the median percentage of marks.

3. Weekly income of 600 families is as under:

Income(in Rs.)	0-1000	1000-2000	2000-3000	3000-4000	4000-5000	5000-6000
No. of Families	250	190	100	40	15	5

Compute the median income.

4. Find the median of the following frequency distribution:

Marks	0 – 5	5 – 10	10 – 15	15 – 20	20 – 25	25 – 30	30 – 35	35 – 40
Number of students	8	12	20	12	18	13	10	7

5. The following table gives the distribution of the life time of 500 neon lamps:

Life time (in hrs)	1500 – 2000	2000 – 2500	2500 – 3000	3000 – 3500	3500 – 4000	4000 – 4500	4500 – 5000
Number of Lamps	24	86	90	115	95	72	18

Find the median life time of a lamp.

6. The lengths of 40 leaves of a plant are measured correct to the nearest millimetre, and the data obtained is represented in the following table. Find the median length of the leaves.

Length(in mm)	118-126	127-135	136-144	145-153	154-162	163-171	172-180
No. of leaves	3	5	9	12	5	4	2

7. Find the median of the following frequency distribution:

Class	75-84	85-94	95-104	105-114	115-124	125-134	135-144
Frequency	8	11	26	31	18	4	2

8. Find the median marks from the following data:

Marks	Below 10	Below 20	Below 30	Below 40	Below 50
Number of students	15	45	90	102	120

9. The following is the cumulative frequency distribution (of less than type) of 1000 persons each of age 20 years and above. Determine the median age.

Age Below(in years)	30	40	50	60	70	80
No. of persons	100	220	350	750	950	1000

10. Find the median age from the following distribution :

Age(in years)	25-29	30-34	35-39	40-44	45-49	50-54	55-59
No. of persons	4	14	22	16	6	5	3

11. Find the median marks for the following distribution:

Marks	Below 10	Below 20	Below 30	Below 40	Below 50	Below 60
No. of Students	6	15	29	41	60	70

12. Find the median marks for the following distribution:

Marks below	10	20	30	40	50	60	70	80
No. of Students	12	32	57	80	92	116	164	200

13. Find the median wages for the following frequency distribution:

Wages per day	61-70	71-80	81-90	91-100	101-110	111-120
No. of workers	5	15	20	30	10	8

14. Find the median marks for the following distribution:

Marks	11-15	16-20	21-25	26-30	31-35	36-40	41-45	46-50
No. of Students	2	3	6	7	14	12	4	2

15. Find the median age of the patients from the following distribution :

Age(in years)	5-14	15-24	25-34	35-44	45-54	55-64
No. of patients	6	11	21	23	14	5

PRACTICE QUESTIONS
CLASS X: CHAPTER - 14
STATISTICS
MODE BASED QUESTIONS

1. Will the median class and modal class of grouped data always be different? Justify your answer.
2. The frequency distribution table of agriculture holdings in a village is given below:

Area of land(in ha)	1-3	3-5	5-7	7-9	9-11	11-13
No. of families	20	45	80	55	40	12

Find the modal agriculture holdings of the village.

3. The weight of coffee in 70 packets is shown below:

Weight (in gm):	200-201	201-202	202-203	203-204	204-205	205-206
No. of packets:	12	26	20	9	2	1

Determine the modal weight.

4. Find the mode marks from the following data:

Marks	Below 10	Below 20	Below 30	Below 40	Below 50
Number of students	15	45	90	102	120

5. Find the mode of the following frequency distribution:

Marks	10 – 20	20 – 30	30 – 40	40 – 50	50 – 60
Number of students	15	30	45	12	18

6. Find the mode of the following frequency distribution:

Marks	Less than 20	Less than 40	Less than 60	Less than 80	Less than 100
Number of students	4	10	28	36	50

7. The following table show the marks of 85 students of a class X in a school. Find the modal marks of the distribution:

Marks(Below)	10	20	30	40	50	60	70	80	90	100
Number of Students	5	9	17	29	45	60	70	78	83	85

8. Find the mode of the following frequency distribution:

Class	25-30	30-35	35-40	40-45	45-50	50-55
Frequency	25	34	50	42	38	14

9. Find the average height of maximum number of students from the following distribution:

Height(in cm)	160-162	163-165	166-168	169-171	172-174
No. of students	15	118	142	127	18

10. Compare the modal ages of two groups of students appearing for an entrance examination:

Age(in years)	16-18	18-20	20-22	22-24	24-26
Group A	50	78	46	28	23
Group B	54	89	40	25	17

11. Find the mode age of the patients from the following distribution :

Age(in years)	6-15	16-25	26-35	36-45	46-55	56-65
No. of patients	6	11	21	23	14	5

12. 100 surnames were randomly picked up from a local telephone directory and the frequency distribution of the number of letters in the English alphabets in the surnames was obtained as follows:

Number of letters	1 - 4	4 - 7	7 - 10	10 - 13	13 - 16	16 - 19
Number of surnames	6	30	40	16	4	4

Determine the median number of letters in the surnames. Find the mean number of letters in the surnames? Also, find the modal size of the surnames.

13. Find the mean, mode and median for the following frequency distribution.

Class	0-10	10-20	20-30	30-40	40-50	Total
Frequency	8	16	36	34	6	100

14. A survey regarding the heights (in cms) of 50 girls of a class was conducted and the following data was obtained.

Height(in cm)	120-130	130-140	140-150	150-160	160-170	Total
No. of girls	2	8	12	20	8	50

Find the mean, median and mode of the above data.

15. Find the mean, mode and median marks for the following frequency distribution.

Marks	Less than 10	Less than 20	Less than 30	Less than 40	Less than 50	Less than 60
No. of Students	2	3	6	7	14	20

16. Find the mean, mode and median for the following frequency distribution.

Class	25-29	30-34	35-39	40-44	45-49	50-54	55-59
Frequency	14	22	16	6	5	3	4

17. Find the mean, mode and median for the following frequency distribution.

Class	0-10	10-20	20-30	30-40	40-50	50-60	60-70
Frequency	5	10	18	30	20	12	5

18. Find the mean, mode and median for the following frequency distribution.

Class	15-19	20-24	25-29	30-34	35-39	40-44	45-49
Frequency	3	13	21	15	5	4	2

19. Find the mean, mode and median for the following frequency distribution.

Class	500-520	520-540	540-560	560-580	580-600	600-620
Frequency	14	9	5	4	3	5

20. Find the mean, mode and median age in years for the following frequency distribution.

Age in years	10 – 19	20 – 29	30 – 39	40 – 49	50 – 59	60 – 69
No. of persons	8	8	10	14	28	32

PRACTICE QUESTIONS
CLASS X: CHAPTER - 14
STATISTICS
MISSING FREQUENCY BASED QUESTIONS

1. The mean of the following distribution is 18. The frequency f in the class interval 19-21 is missing. Determine f .

Class	11-13	13-15	15-17	17-19	19-21	21-23	23-25
Frequency	3	6	9	13	f	5	4

2. The mean of the following distribution is 24. Find the value of p .

Marks	0-10	10-20	20-30	30-40	40-50	50-60
No. of Students	15	20	35	P	10	42

3. Find the missing frequencies f_1 and f_2 in table given below; it is being given that the mean of the given frequency distribution is 50.

Class	0-20	20-40	40-60	60-80	80-100	Total
Frequency	17	f_1	32	f_2	19	120

4. Find the missing frequencies f_1 and f_2 in table given below; it is being given that the mean of the given frequency distribution is 145.

Class	100-120	120-140	140-160	160-180	180-200	Total
Frequency	10	f_1	f_2	15	5	80

5. The mean of the following frequency distribution is 57.6 and the sum of the observations is 50. Find f_1 and f_2 .

Class	0-20	20-40	40-60	60-80	80-100	100-120
Frequency	7	f_1	12	f_2	8	5

6. The mean of the following frequency distribution is 28 and the sum of the observations is 100. Find f_1 and f_2 .

Marks	0-10	10-20	20-30	30-40	40-50	50-60
No. of Students	12	18	f_1	20	f_2	6

7. The mean of the following frequency distribution is 53. But the frequencies a and b in the classes 20-40 and 60-80 are missing. Find the missing frequencies.

Age (in years)	0 - 20	20 - 40	40 - 60	60 - 80	80 - 100	Total
Number of people	15	a	21	b	17	100

8. Compute the missing frequencies x and y in the following data if the mean is $166\frac{9}{26}$ and the sum of the frequencies is 52:

Class Interval	140 – 150	150 – 160	160 – 170	170 – 180	180 – 190	190 – 200
Frequency	5	x	20	y	6	2

9. If the median of the distribution given below is 28.5, find the values of x and y .

C. I.	0 - 10	10 - 20	20 - 30	30 - 40	40 - 50	50 - 60
F	5	x	20	15	y	5

10. The median of the following data is 525. Find the values of x and y , if the total frequency is 100.

C.I	0-100	100-200	200-300	300-400	400-500	500-600	600-700	700-800	800-900	900-1000
F	2	5	x	12	17	20	y	9	7	4

11. The median of the following data is 28. Find the values of x and y , if the total frequency is 50.

Marks	0-7	7-14	14-21	21-28	28-35	35-42	42-49
No. of Students	3	x	7	11	y	16	9

12. Find the missing frequencies in the following frequency distribution table, if the total frequency is 100 and median is 32.

Marks	0-10	10-20	20-30	30-40	40-50	50-60
No. of Students	10	x	25	30	y	10

13. Find the missing frequencies in the following frequency distribution table, if the total frequency is 70 and median is 35.

Marks	0-10	10-20	20-30	30-40	40-50	50-60
No. of Students	6	9	x	y	19	10

14. The median of the following data is 167. Find the values of x .

Height(in cm)	160-162	163-165	166-168	169-171	172-174
Frequency	15	117	x	118	14

15. The mode of the following data is 36. Find the values of x .

Class	0-10	10-20	20-30	30-40	40-50	50-60	60-70
Frequency	8	10	x	16	12	6	7

16. Find the missing frequencies in the following frequency distribution table, if the total frequency is 100 and mode is $46\frac{2}{3}$.

Class	0-10	10-20	20-30	30-40	40-50	50-60	60-70	70-80
Frequency	5	8	7	x	28	20	10	y

PRACTICE QUESTIONS
CLASS X: CHAPTER - 14
STATISTICS
OGIVE BASED QUESTIONS

- Is it correct to say that an ogive is a graphical representation of a frequency distribution? Give reason.
- Which measure of central tendency is given by the x – coordinate of the point of intersection of the more than ogive and less than ogive?
- The following is the distribution of weights (in kg) of 40 persons:

Weight(in kg)	40-45	45-50	50-55	55-60	60-65	65-70	70-75	75-80
No. of persons	4	4	13	5	6	5	2	1

Construct a cumulative frequency distribution (of less than type) table for the data above.

- Find the unknown entries a, b, c, d, e, f in the following distribution of heights of students in a class:

Height(in cm)	150-155	155-160	160-165	165-170	170-175	175-180
Frequency	12	b	10	d	e	2
Cumulative Frequency	a	25	c	43	48	f

- Following is the age distribution of a group of students. Draw the cumulative frequency curve less than type and hence obtain the median from the graph.

Age(in years)	4-5	5-6	6-7	7-8	8-9	9-10	10-11	11-12	12-13	13-14	14-15	15-16
No. of students	36	42	52	60	68	84	96	82	66	48	50	16

- For the following distribution, draw the cumulative frequency curve more than type and hence obtain the median from the graph.

Class	0-10	10-20	20-30	30-40	40-50	50-60	60-70
Frequency	5	15	20	23	17	11	9

- Draw less than ogive for the following frequency distribution:

Marks	0 – 10	10 – 20	20 – 30	30 – 40	40 – 50	50 – 60
Number of students	5	8	6	10	6	6

Also find the median from the graph and verify that by using the formula.

- The table given below shows the frequency distribution of the cores obtained by 200 candidates in a BCA examination.

Score	200-250	250-300	300-350	350-400	400-450	450-500	500-550	550-600
No. of students	30	15	45	20	25	40	10	15

Draw cumulative frequency curves by using (i) less than type and (ii) more than type. Hence find median

- Draw less than and more than ogive for the following frequency distribution:

Marks	0 – 10	10 – 20	20 – 30	30 – 40	40 – 50	50 – 60
Number of students	8	5	10	6	6	6

Also find the median from the graph and verify that by using the formula.

10. The following table gives production yield per hectare of wheat of 100 farms of a village.

production yield (in kg/ha)	50 - 55	55 - 60	60 - 65	65 - 70	70 - 75	75 - 80
Number of farms	2	8	12	24	38	16

Change the distribution to a more than type distribution, and draw its ogive.

11. The following table gives the heights (in meters) of 360 trees:

Height (in m)	Less than 7	Less than 14	Less than 21	Less than 28	Less than 35	Less than 42	Less than 49	Less than 56
No. of trees	25	45	95	140	235	275	320	360

From the above data, draw an ogive and find the median

12. From the following data, draw the two types of cumulative frequency curves and determine the median from the graph.

Height(in cm)	Frequency
140-144	3
144-148	9
148-152	24
152-156	31
156-160	42
160-164	64
164-168	75
168-172	82
172-176	86
176-180	34

13. For the following distribution, draw the cumulative frequency curve more than type and hence obtain the median from the graph.

Marks	Below 10	Below 20	Below 30	Below 40	Below 50	Below 60
No. of Students	6	15	29	41	60	70

14. For the following distribution, draw the cumulative frequency curve less than type and hence obtain the median from the graph.

Age equal and above(in years)	0	10	20	30	40	50	60	70
No. of Persons	100	90	75	50	25	15	5	0

15. During the medical check-up of 35 students of a class, their weights were recorded as follows: Draw a less than type ogive for the given data. Hence obtain the median weight from the graph and verify the result by using the formula.

Weight (in kg)	Less than 38	Less than 40	Less than 42	Less than 44	Less than 46	Less than 48	Less than 50	Less than 52
No. of students	0	3	5	9	14	28	32	35



CLASS X : CHAPTER - 15 PROBABILITY

IMPORTANT FORMULAS & CONCEPTS

PROBABILITY

Experimental or empirical probability $P(E)$ of an event E is

$$P(E) = \frac{\text{Number of trials in which the event happened}}{\text{Total number of trials}}$$

The theoretical probability (also called classical probability) of an event A , written as $P(A)$, is defined as

$$P(A) = \frac{\text{Number of outcomes favourable to A}}{\text{Number of all possible outcomes of the experiment}}$$

Two or more events of an experiment, where occurrence of an event prevents occurrences of all other events, are called **Mutually Exclusive Events**.

COMPLIMENTARY EVENTS AND PROBABILITY

We denote the event 'not E ' by \bar{E} . This is called the **complement** event of event E .

$$\text{So, } P(E) + P(\bar{E}) = 1$$

i.e., $P(E) + P(\bar{E}) = 1$, which gives us $P(\bar{E}) = 1 - P(E)$.

In general, it is true that for an event E , $P(\bar{E}) = 1 - P(E)$





















































- ☞ The probability of an event which is impossible to occur is 0. Such an event is called an **impossible event**.
- ☞ The probability of an event which is sure (or certain) to occur is 1. Such an event is called a **sure event** or a **certain event**.
- ☞ The probability of an event E is a number $P(E)$ such that $0 \leq P(E) \leq 1$
- ☞ An event having only one outcome is called an elementary event. The sum of the probabilities of all the elementary events of an experiment is 1.

DECK OF CARDS AND PROBABILITY

A deck of playing cards consists of 52 cards which are divided into 4 suits of 13 cards each. They are black spades (♠) red hearts (♥), red diamonds (♦) and black clubs (♣).

The cards in each suit are Ace, King, Queen, Jack, 10, 9, 8, 7, 6, 5, 4, 3 and 2. Kings, Queens and Jacks are called face cards.

Example set of 52 poker playing cards

Suit	Ace	2	3	4	5	6	7	8	9	10	Jack	Queen	King
Clubs													
Diamonds													
Hearts													
Spades													

Equally likely events : Two or more events are said to be equally likely if each one of them has an equal chance of occurrence.

Mutually Exclusive events : Two or more events are mutually exclusive if the occurrence of each event prevents the every other event.

Complementary events : Consider an event has few outcomes. Event of all other outcomes in the sample survey which are not in the favourable event is called Complementary event.

Exhaustive events : All the events are exhaustive events if their union is the sample space.

Sure events : The sample space of a random experiment is called sure or certain event as any one of its elements will surely occur in any trail of the experiment.

Impossible event : An event which will occur on any account is called an impossible event.



MCQ WORKSHEET-I
CLASS X: CHAPTER - 15
PROBABILITY

1. There are 6 marbles in a box with number 1 to 6 marked on each of them . What is the probability of drawing a marble with number 2 ?
(a) $\frac{1}{6}$ (b) $\frac{1}{5}$ (c) $\frac{1}{3}$ (d) 1
2. A coin is flipped to decide which team starts the game . What is the probability of your team will start ?
(a) $\frac{1}{4}$ (b) $\frac{1}{2}$ (c) 1 (d) 0
3. A die is thrown once . What will be the probability of getting a prime number ?
(a) $\frac{1}{6}$ (b) $\frac{1}{2}$ (c) 1 (d) 0

Cards marked with numbers 1 to 25 are placed in the box and mixed thoroughly. One card is drawn at random from the box. Answer the following questions (Q4-Q13)

4. What is the probability of getting a number 5?
(a) 1 (b) 0 (c) $\frac{1}{25}$ (d) $\frac{1}{5}$
5. What is the probability of getting a number less than 11?
(a) 1 (b) 0 (c) $\frac{1}{5}$ (d) $\frac{2}{5}$
6. What is the probability of getting a number greater than 25?
(a) 1 (b) 0 (c) $\frac{1}{5}$ (d) $\frac{2}{5}$
7. What is the probability of getting a multiple of 5?
(a) 1 (b) 0 (c) $\frac{1}{25}$ (d) $\frac{1}{5}$
8. What is the probability of getting an even number?
(a) 1 (b) 0 (c) $\frac{12}{25}$ (d) $\frac{13}{25}$
9. What is the probability of getting an odd number?
(a) 1 (b) 0 (c) $\frac{12}{25}$ (d) $\frac{13}{25}$
10. What is the probability of getting a prime number?
(a) $\frac{8}{25}$ (b) $\frac{9}{25}$ (c) $\frac{12}{25}$ (d) $\frac{13}{25}$

11. What is the probability of getting a number divisible by 3?

- (a) $\frac{8}{25}$ (b) $\frac{9}{25}$ (c) $\frac{12}{25}$ (d) $\frac{13}{25}$

12. What is the probability of getting a number divisible by 4?

- (a) $\frac{8}{25}$ (b) $\frac{9}{25}$ (c) $\frac{6}{25}$ (d) $\frac{3}{25}$

13. What is the probability of getting a number divisible by 7?

- (a) $\frac{8}{25}$ (b) $\frac{9}{25}$ (c) $\frac{6}{25}$ (d) $\frac{3}{25}$

14. A bag has 4 red balls and 2 yellow balls. A ball is drawn from the bag without looking into the bag. What is probability of getting a red ball?

- (a) $\frac{1}{6}$ (b) $\frac{2}{3}$ (c) $\frac{1}{3}$ (d) 1

15. A bag has 4 red balls and 2 yellow balls. A ball is drawn from the bag without looking into the bag. What is probability of getting a yellow ball?

- (a) $\frac{1}{6}$ (b) $\frac{2}{3}$ (c) $\frac{1}{3}$ (d) 1



MCQ WORKSHEET-II
CLASS X: CHAPTER - 15
PROBABILITY

A box contains 3 blue, 2 white, and 5 red marbles. If a marble is drawn at *random* from the box, then answer the questions from 1 to 5.

1. What is the probability that the marble will be white?

- (a) $\frac{1}{6}$ (b) $\frac{1}{5}$ (c) $\frac{1}{3}$ (d) 1

2. What is the probability that the marble will be red?

- (a) $\frac{1}{6}$ (b) $\frac{1}{2}$ (c) 1 (d) 0

3. What is the probability that the marble will be blue?

- (a) $\frac{3}{10}$ (b) $\frac{1}{2}$ (c) 1 (d) 0

4. What is the probability that the marble will be any one colour?

- (a) $\frac{1}{6}$ (b) $\frac{1}{2}$ (c) 1 (d) 0

5. What is the probability that the marble will be red or blue?

- (a) 1 (b) $\frac{4}{5}$ (c) $\frac{1}{5}$ (d) $\frac{2}{5}$

A die is thrown once, then answer the questions from 6 to 10.

6. Find the probability of getting a prime number

- (a) $\frac{1}{6}$ (b) $\frac{1}{2}$ (c) 1 (d) 0

7. Find the probability of getting a number lying between 2 and 6

- (a) $\frac{1}{6}$ (b) $\frac{1}{2}$ (c) 1 (d) 0

8. Find the probability of getting an odd number.

- (a) $\frac{1}{6}$ (b) $\frac{1}{2}$ (c) 1 (d) 0

9. Find the probability of getting an even number.

- (a) $\frac{1}{6}$ (b) $\frac{1}{2}$ (c) 1 (d) 0

10. Find the probability of getting a number greater than 4.

- (a) $\frac{1}{6}$ (b) $\frac{2}{3}$ (c) $\frac{1}{3}$ (d) 1

MCQ WORKSHEET-III
CLASS X: CHAPTER - 15
PROBABILITY

A box contains 5 red marbles, 6 white marbles and 4 green marbles. If a marble is drawn at random from the box, then answer the questions from 1 to 6.

1. What is the probability that the marble will be white?

- (a) $\frac{1}{6}$ (b) $\frac{2}{3}$ (c) $\frac{1}{3}$ (d) 1

2. What is the probability that the marble will be red?

- (a) $\frac{1}{6}$ (b) $\frac{2}{3}$ (c) $\frac{1}{3}$ (d) 1

3. What is the probability that the marble will be green?

- (a) 0.3 (b) $\frac{1}{2}$ (c) 1 (d) none of these

4. What is the probability that the marble will be any one colour?

- (a) $\frac{1}{6}$ (b) $\frac{1}{2}$ (c) 1 (d) 0

5. What is the probability that the marble will be red or green?

- (a) $\frac{2}{5}$ (b) $\frac{3}{25}$ (c) $\frac{1}{5}$ (d) none of these

6. What is the probability that the marble will be blue?

- (a) $\frac{1}{6}$ (b) $\frac{1}{2}$ (c) 1 (d) 0

Cards marked with numbers 1 to 50 are placed in the box and mixed thoroughly. One card is drawn at random from the box. Answer the following questions from 7 to 15.

7. What is the probability of getting a number 5?

- (a) 1 (b) 0 (c) $\frac{1}{25}$ (d) $\frac{1}{5}$

8. What is the probability of getting a number less than 11?

- (a) 1 (b) 0 (c) $\frac{1}{5}$ (d) $\frac{2}{5}$

9. What is the probability of getting a number greater than 50?

- (a) 1 (b) 0 (c) $\frac{1}{5}$ (d) $\frac{2}{5}$

10. What is the probability of getting a multiple of 5?

- (a) 1 (b) 0 (c) $\frac{1}{25}$ (d) $\frac{1}{5}$

11. What is the probability of getting an even number?

- (a) 1 (b) $\frac{1}{2}$ (c) $\frac{12}{25}$ (d) $\frac{13}{25}$

12. What is the probability of getting an odd number?

- (a) 1 (b) $\frac{1}{2}$ (c) $\frac{12}{25}$ (d) $\frac{13}{25}$

13. What is the probability of getting a prime number?

- (a) 1 (b) $\frac{1}{2}$ (c) $\frac{4}{10}$ (d) $\frac{3}{10}$

14. What is the probability of getting a number divisible by 3?

- (a) $\frac{8}{25}$ (b) $\frac{9}{25}$ (c) $\frac{12}{25}$ (d) $\frac{13}{25}$

15. What is the probability of getting a number divisible by 4?

- (a) $\frac{8}{25}$ (b) $\frac{9}{25}$ (c) $\frac{6}{25}$ (d) $\frac{3}{25}$

16. What is the probability of getting a number divisible by 7?

- (a) $\frac{8}{25}$ (b) $\frac{9}{25}$ (c) $\frac{6}{25}$ (d) $\frac{3}{25}$



MCQ WORKSHEET-IV
CLASS X: CHAPTER - 15
PROBABILITY

1. A coin is tossed 1000 times and 560 times a "head" occurs. The empirical probability of occurrence of a Head in this case is
- A. 0.5 B. 0.56 C. 0.44 D. 0.056

2. Two coins are tossed 200 times and the following out comes are recorded

HH	HT/TH	TT
56	110	34

What is the empirical probability of occurrence of at least one Head in the above case

- A. 0.33 B. 0.34 C. 0.66 D. 0.83

A die is thrown 200 times and the following outcomes are noted, with their frequencies:

Outcome	1	2	3	4	5	6
Frequency	56	22	30	42	32	18

3. What is the empirical probability of getting a 1 in the above case.
- A. 0.28 B. 0.22 C. 0.15 D. 0.21

4. What is the empirical probability of getting a number less than 4 ?
- A. 0.50 B. 0.54 C. 0.46 D. 0.52

5. What is the empirical probability. of getting a number greater than 4.
- A. 0.32 B. 0.25 C. 0.18 D. 0.30

6. On a particular day, the number of vehicles passing a crossing is given below :

Vehicle	Two wheeler	Three wheeler	Four wheeler
Frequency	52	71	77

What is the probability of a two wheeler passing the crossing on that day ?

- A. 0.26 B. 0.71 C. 0.385 D. 0.615

7. The following table shows the blood-group of 100 students

Blood group	A	B	O	AB	B ⁺
Number of Students	12	23	35	20	10

One student is taken at random. What is probability that his blood group is B⁺

- A. 0.12 B. 0.35 C. 0.20 D. 0.10

8. In a bag, there are 100 bulbs out of which 30 are bad ones. A bulb is taken out of the bag at random. The probability of the selected bulb to be good is

- A. 0.50 B. 0.70 C. 0.30 D. None of these

9. On a page of telephone directory having 250 telephone numbers, the Frequency of the unit digits of those number are given below :

0	1	2	3	4	5	6	7	8	9
18	22	32	28	40	30	30	22	18	10

A telephone number is selected from the page at random. What is the probability that its unit digit is

(a) 2

- A. 0.16 B. 0.128 C. 0.064 D. 0.04

(b) More than 6

- A. 0.20 B. 0.25 C. 0.32 D. 0.16

(c) less than 2

- A. 0.16 B. 0.18 C. 0.22 D. 0.32

10. 10 defective pens are accidentally mixed with 90 good ones. It is not possible to just look at a pen and tell whether or not it is defective. One pen is taken out at random from this lot. Determine the probability that the pen taken out is a good one.

- A. 0.10 B. 0.20 C. 0.90 D. 1.0



MCQ WORKSHEET-V
CLASS X: CHAPTER - 15
PROBABILITY

One card is drawn from a well-shuffled deck of 52 cards. Answer the question from 1 to 12.

1. Find the probability of getting a king of red colour
(a) $\frac{1}{26}$ (b) $\frac{2}{13}$ (c) $\frac{1}{13}$ (d) $\frac{3}{26}$
2. Find the probability of getting a face card.
(a) $\frac{1}{26}$ (b) $\frac{2}{13}$ (c) $\frac{1}{13}$ (d) $\frac{3}{13}$
3. Find the probability of getting a black face card
(a) $\frac{1}{26}$ (b) $\frac{2}{13}$ (c) $\frac{1}{13}$ (d) $\frac{3}{26}$
4. Find the probability of getting an ace.
(a) $\frac{1}{26}$ (b) $\frac{2}{13}$ (c) $\frac{1}{13}$ (d) $\frac{3}{26}$
5. Find the probability of getting a black card.
(a) $\frac{1}{2}$ (b) $\frac{2}{13}$ (c) $\frac{1}{13}$ (d) $\frac{3}{26}$
6. Find the probability of getting a face card or an ace.
(a) $\frac{4}{13}$ (b) $\frac{2}{13}$ (c) $\frac{1}{13}$ (d) $\frac{3}{13}$
7. Find the probability of getting face card or black card.
(a) $\frac{4}{13}$ (b) $\frac{8}{13}$ (c) $\frac{7}{13}$ (d) $\frac{3}{13}$
8. Find the probability of getting a king or red card.
(a) $\frac{4}{13}$ (b) $\frac{8}{13}$ (c) $\frac{7}{13}$ (d) $\frac{3}{13}$
9. Find the probability of getting a king and red card.
(a) $\frac{1}{26}$ (b) $\frac{2}{13}$ (c) $\frac{1}{13}$ (d) $\frac{3}{26}$
10. Find the probability of getting a king or queen card.
(a) $\frac{1}{26}$ (b) $\frac{2}{13}$ (c) $\frac{1}{13}$ (d) $\frac{3}{26}$

PRACTICE QUESTIONS
CLASS X : CHAPTER – 15
PROBABILITY : DICE BASED QUESTIONS

1. An unbiased die is thrown. What is the probability of getting
 - a). an even number
 - b). a multiple of 3
 - c). a multiple of 2 or 3
 - d). a number less than 5 divisible by 2.
 - e). A number greater than 2 divisible by 3.
 - f). an even number or a multiple of 3
 - g). an even number and a multiple of 3
 - h). a number 3 or 4
 - i). an odd number
 - j). a number less than 5
 - k). a number greater than 3
 - l). a number between 3 and 6.
2. Two dice are thrown together. Find the probability that the product of the numbers on the top of the dice is (i) 6 (ii) 12 (iii) 7
3. Two dice are thrown at the same time and the product of numbers appearing on them is noted. Find the probability that the product is less than 9.
4. Two dice are numbered 1, 2, 3, 4, 5, 6 and 1, 1, 2, 2, 3, 3, respectively. They are thrown and the sum of the numbers on them is noted. Find the probability of getting each sum from 2 to 9 separately.
5. Two dice are thrown at the same time. Determine the probability that the difference of the numbers on the two dice is 2.
6. Two dice are thrown at the same time. Find the probability of getting (i) same number on both dice. (ii) different numbers on both dice.
7. Two dice are thrown simultaneously. What is the probability that the sum of the numbers appearing on the dice is (i) 7? (ii) a prime number? (iii) 1?
8. Two dice are thrown simultaneously. Find the probability of getting
 - a). an even number on first dice
 - b). an odd number on first dice
 - c). an even number as the sum
 - d). a multiple of 5 as the sum
 - e). a multiple of 7 as the sum
 - f). a multiple of 3 as the sum
 - g). a sum more than 7
 - h). a sum greater than 9
 - i). neither the sum 9 nor the sum 11 as the sum
 - j). a sum less than 6

- k).** a sum less than 7
 - l).** a sum more than 7
 - m).** a multiple of 3 on one dice
 - n).** a multiple of 2 on one dice
 - o).** a multiple of 5 on one dice
 - p).** a multiple of 2 on one dice and a multiple of 3 on the other
 - q).** a doublet
 - r).** a doublet of even number
 - s).** a doublet of odd number
 - t).** a doublet of prime number
 - u).** a number other than 5 on any dice
 - v).** a number other than 3 on any dice
 - w).** the sum equal to 12.
 - x).** the sum greater than equal to 10
 - y).** the sum less than or equal to 10
 - z).** the sum as a prime number
-

PRACTICE QUESTIONS
CLASS X : CHAPTER – 15
PROBABILITY
PLAYING CARDS BASED QUESTIONS

1. One card is drawn from a well-shuffled deck of 52 cards. Find the probability of getting
- (a) an ace card
 - (b) a red card
 - (c) either red or king card
 - (d) red and a king
 - (e) '2' of spades
 - (f) '10' of a black suit
 - (g) a queen of black suit
 - (h) either a black card or a king
 - (i) black and king card
 - (j) a jack, queen or a king
 - (k) a heart card
 - (l) a queen card
 - (m) the ace of spades
 - (n) the seven of clubs
 - (o) a ten
 - (p) a black card
 - (q) neither a heart nor a king
 - (r) neither an ace nor a king
 - (s) neither a red card nor a queen card
 - (t) a face card or an ace
 - (u) a face card or a black card
 - (v) a face card and a black card
 - (w) neither a face card nor an ace
 - (x) neither a face card nor '10' card
 - (y) either a king or red card
 - (z) either an ace or black card
 - (aa) an ace and a black card
 - (bb) a king of red colour card
 - (cc) a face card
 - (dd) a red face card
 - (ee) the jack of hearts
 - (ff) a spade card
 - (gg) the queen of diamonds
 - (hh) '9' of black suit
 - (ii) a face card or spade card
2. Five cards—the ten, jack, queen, king and ace of diamonds, are well-shuffled with their face downwards. One card is then picked up at random.
- (i) What is the probability that the card is the queen?
 - (ii) If the queen is drawn and put aside, what is the probability that the second card picked up is (a) an ace? (b) a queen?

3. The king , queen and jack of clubs are removed from a pack of 52 playing cards. One card is selected at random from the remaining cards. Find the probability that the card is
- (a) neither a heart nor a king
 - (b) neither an ace nor a king
 - (c) neither a red card nor a queen card
 - (d) a black card or an ace.
 - (e) either a heart or a spade card
 - (f) a king card
 - (g) a heart card
 - (h) a red card
 - (i) a black card
 - (j) a spade card
 - (k) a diamond card
 - (l) a club card
 - (m) either an ace card or black card
 - (n) an ace card
 - (o) a face card
 - (p) a face card with red colour
 - (q) neither '10' card nor an ace
 - (r) an even number card
 - (s) an odd number card
 - (t) not a natural number.
6. All spades are removed from a well shuffled deck of 52 cards and then one card is drawn randomly from the remaining cards. Find the probability of getting
- (a) neither a heart nor a king
 - (b) neither an ace nor a king
 - (c) neither a red card nor a queen card
 - (d) a black card or an ace.
 - (e) either a heart or a spade card
 - (f) a red card
 - (g) a black card
 - (h) a spade card
 - (i) a diamond card
 - (j) a club card
 - (k) either an ace card or black card
 - (l) an ace card
 - (m) a face card with red colour
 - (n) neither '10' card nor an ace
 - (o) an even number card
 - (p) a face card
 - (q) an odd number card
4. All face cards are removed from a well shuffled deck of 52 cards and then one card is drawn randomly from the remaining cards. Find the probability of getting
- (a) neither a heart nor a king

- (b) neither an ace nor a king
- (c) neither a red card nor a queen card
- (d) a black card or an ace.
- (e) either a heart or a spade card
- (f) a red card
- (g) a black card
- (h) a spade card
- (i) a diamond card
- (j) a club card
- (k) either an ace card or black card
- (l) an ace card
- (m) a face card with red colour
- (n) neither '10' card nor an ace
- (o) an even number card
- (p) an odd number card

5. All cards of ace, jack and queen are removed from a deck of playing cards. One card is drawn at random from the remaining cards, find the probability that the card drawn

- (a) neither a heart nor a king
- (b) neither an ace nor a king
- (c) neither a red card nor a queen card
- (d) a black card or an ace.
- (e) either a heart or a spade card
- (f) a king card
- (g) a heart card
- (h) a red card
- (i) a black card
- (j) a spade card
- (k) a diamond card
- (l) a club card
- (m) either an ace card or black card
- (n) an ace card
- (o) a face card
- (p) a face card with red colour
- (q) neither '10' card nor an ace
- (r) an even number card
- (s) an odd number card
- (t) not a natural number.

6. All cards of '10', an ace and queen cards are removed from a well shuffled deck of 52 cards and then one card is drawn randomly from the remaining cards. Find the probability of getting

- (a) neither a heart nor a king
- (b) neither an ace nor a king
- (c) neither a red card nor a queen card
- (d) a black card or an ace.
- (e) either a heart or a spade card
- (f) a king card
- (g) a heart card

- (h) a red card
- (i) a black card
- (j) a spade card
- (k) a diamond card
- (l) a club card
- (m) either an ace card or black card
- (n) an ace card
- (o) a face card
- (p) a face card with red colour
- (q) neither '10' card nor an ace
- (r) an even number card
- (s) an odd number card
- (t) not a natural number.

7. Five cards—the ten, jack, queen, king and ace of diamonds, are removed from the well-shuffled 52 playing cards. One card is then picked up at random. Find the probability of getting

- (a) neither a heart nor a king
- (b) neither an ace nor a king
- (c) neither a red card nor a queen card
- (d) a black card or an ace.
- (e) either a heart or a spade card
- (f) a king card
- (g) a heart card
- (h) a red card
- (i) a black card
- (j) a spade card
- (k) a diamond card
- (l) a club card
- (m) either an ace card or black card
- (n) an ace card
- (o) a face card
- (p) a face card with red colour
- (q) neither '10' card nor an ace
- (r) an even number card
- (s) an odd number card
- (t) not a natural number.



PRACTICE QUESTIONS
CLASS X : CHAPTER – 15
PROBABILITY : COINS BASED QUESTIONS

1. Two coins are tossed simultaneously. Find the probability of getting
 - i). at least one head
 - ii). at most one head
 - iii). exactly two head
 - iv). exactly one head
 - v). no head
 - vi). no tail
 - vii). at least one tail
 - viii). at most one tail
 - ix). exactly two tails
 - x). exactly one tail

2. A coin is tossed two times. Find the probability of getting at most one head.

3. A coin is tossed 3 times. List the possible outcomes. Find the probability of getting (i) all heads
(ii) at least 2 heads

4. Sushma tosses a coin 3 times and gets tail each time. Do you think that the outcome of next toss will be a tail? Give reasons.

5. If I toss a coin 3 times and get head each time, should I expect a tail to have a higher chance in the 4th toss? Give reason in support of your answer.

6. Three coins are tossed simultaneously. What is the probability of getting
 - i). exactly two heads
 - ii). at least two heads
 - iii). at most two heads
 - iv). one head or two heads
 - v). exactly one tail
 - vi). at least one tail
 - vii). at most one tail
 - viii). at least two tails
 - ix). at most two tails
 - x). exactly two tails
 - xi). no head
 - xii). no tail

7. Four coins are tossed simultaneously. What is the probability of getting
 - i). exactly one head
 - ii). exactly two heads
 - iii). exactly three heads
 - iv). at least one head
 - v). at most one head

- vi).** at least three heads
 - vii).** at most three heads
 - viii).** at least two heads
 - ix).** at most two heads
 - x).** one head or two heads
 - xi).** exactly one tail
 - xii).** at least one tail
 - xiii).** at most one tail
 - xiv).** at least two tails
 - xv).** at most two tails
 - xvi).** at least three tails
 - xvii).** at most three tails
 - xviii).** exactly two tails
 - xix).** no head
 - xx).** no tail
-

PRACTICE QUESTIONS
CLASS X : CHAPTER – 15
PROBABILITY
BAG BALLS BASED QUESTIONS

1. A bag contains 3 red balls and 5 black balls. A ball is drawn at random from the bag. What is the probability that the ball drawn is
 1. red ?
 2. not red?

2. A bag contains 5 red, 8 green and 7 white balls. One ball is drawn at random from the bag, find the probability of getting
 3. a white ball or a green ball
 4. neither green ball nor red ball.
 5. not green?
 6. not red?
 7. not white?
 8. neither red ball nor white ball?

3. A bag contains 5 red balls, 8 white balls and 4 green balls. One ball is taken out of the bag at random. What is the probability that the ball taken out will be
 9. red ?
 10. white ?
 11. not green?
 12. not red?
 13. not white?
 14. neither red ball nor white ball?

4. A box contains 3 blue, 2 white, and 4 red balls. If a ball is drawn at *random* from the box, what is the probability that it will be
 15. white?
 16. blue?
 17. red?
 18. neither blue ball nor red ball?
 19. neither blue ball nor white ball?
 20. neither white ball nor red ball?
 21. not blue?
 22. not red?
 23. not white?

5. A bag contains 4 blue, 5 black, 6 red and 5 white balls. One ball is taken out of the bag at random. What is the Probability that it will be
 24. black?
 25. blue?
 26. red?
 27. white?
 28. black or blue?
 29. white or blue?

30. red or blue?
31. white or red?
32. neither blue ball nor red ball?
33. neither red ball nor white ball?
34. neither blue ball nor black ball?
35. not blue ball?
36. not red ball?
37. not white ball?
38. not black ball?

6. A bag contains 9 blue, 4 black, 5 red and 7 white balls. One ball is taken out of the bag and found red ball then again one ball is taken out at random from the remaining. What is the Probability that it will be

39. black?
40. blue?
41. red?
42. white?
43. black or blue?
44. white or blue?
45. red or blue?
46. white or red?
47. neither blue ball nor red ball?
48. neither red ball nor white ball?
49. neither blue ball nor black ball?
50. not blue ball?
51. not red ball?
52. not white ball?
53. not black ball?



PRACTICE QUESTIONS
CLASS X : CHAPTER – 15
PROBABILITY : NUMBER BASED QUESTIONS

1. On one page of a telephone directory, there were 200 telephone numbers. The frequency distribution of their unit place digit (for example, in the number 25828573, the unit place digit is 3) is given in below table:

Digit	0	1	2	3	4	5	6	7	8	9
Frequency	22	26	22	22	20	10	14	28	16	20

Without looking at the page, the pencil is placed on one of these numbers, i.e., the number is chosen at *random*. What is the probability that the digit in its unit place is (i) an odd number (ii) a prime number and (iii) a number greater than 4.?

2. A box contains 90 discs which are numbered from 1 to 90. If one disc is drawn at random from the box, find the probability that it bears
- a two-digit number
 - a perfect square number
 - a number divisible by 5.
 - a number divisible by 2 or 3.
 - a number divisible by 2 and 3.
 - a number divisible by 7.
 - a number multiple of 8.
 - a two digit number divisible by 5.
 - a two digit number divisible by 2.
 - a two digit number divisible by 3.
 - a two digit number divisible by 4.
 - a two digit number perfect square.
 - neither divisible by 5 nor 10.
 - neither divisible by 2 nor 5.
 - neither divisible by 3 nor 5.
 - a perfect cube number.
 - a prime number
 - a two digit prime number.
 - an even prime number.
 - a number is not divisible by 5.
 - a number is not divisible by 3.
 - a number is not divisible by 2 and 3.
3. Cards are marked with numbers 4, 5, 6,50 are placed in the box and mixed thoroughly. One card is drawn at random from the box. What is the probability of getting
- a two-digit number
 - a perfect square number
 - a number divisible by 5.
 - a number divisible by 2 or 3.
 - a number divisible by 2 and 3.
 - a number divisible by 7.
 - a number multiple of 8.
 - a two digit number divisible by 5.
 - a two digit number divisible by 2.
 - a two digit number divisible by 3.
 - a two digit number divisible by 4.

- l).** a two digit number perfect square.
- m).** neither divisible by 5 nor 10.
- n).** neither divisible by 2 nor 5.
- o).** neither divisible by 3 nor 5.
- p).** a perfect cube number.
- q).** a prime number
- r).** a two digit prime number.
- s).** an even prime number.
- t).** a number is not divisible by 5.
- u).** a number is not divisible by 3.
- v).** a number is not divisible by 2 and 3.

4. Cards are marked with numbers 13, 14, 15,60 are placed in the box and mixed thoroughly. One card is drawn at random from the box. What is the probability of getting

- a).** a two-digit number
- b).** a perfect square number
- c).** a number divisible by 5.
- d).** a number divisible by 2 or 3.
- e).** a number divisible by 2 and 3.
- f).** a number divisible by 7.
- g).** a number multiple of 8.
- h).** a two digit number divisible by 5.
- i).** a two digit number divisible by 2.
- j).** a two digit number divisible by 3.
- k).** a two digit number divisible by 4.
- l).** a two digit number perfect square.
- m).** a perfect cube number.
- n).** a prime number.
- o).** neither divisible by 5 nor 10.
- p).** neither divisible by 2 nor 5.
- q).** neither divisible by 3 nor 5.
- r).** a two digit prime number.
- s).** an even prime number.
- t).** a number is not divisible by 5.
- u).** a number is not divisible by 3.
- v).** a number is not divisible by 2 and 3.

5. There are 30 cards numbered from 1 to 30. One card is drawn at random. Find the probability of getting the card with

- a).** a two-digit number
- b).** a perfect square number
- c).** a number divisible by 5.
- d).** a number divisible by 2 or 3.
- e).** a number divisible by 2 and 3.
- f).** a number divisible by 7.
- g).** a number multiple of 8.
- h).** a two digit number divisible by 5.
- i).** a two digit number divisible by 2.
- j).** a two digit number divisible by 3.
- k).** a two digit number divisible by 4.
- l).** a two digit number perfect square.
- m).** a perfect cube number.
- n).** a prime number.
- o).** neither divisible by 5 nor 10.

- p). neither divisible by 2 nor 5.
- q). neither divisible by 3 nor 5.
- r). a two digit prime number.
- s). an even prime number.
- t). a number is not divisible by 5.
- u). a number is not divisible by 3.
- v). a number is not divisible by 2 and 3.

6. A box contains 25 cards numbered from 1 to 25. A card is drawn from the box at random. Find the probability of getting the card with

- a). a two-digit number
- b). a perfect square number
- c). a number divisible by 5.
- d). a number divisible by 2 or 3.
- e). a number divisible by 2 and 3.
- f). a number divisible by 7.
- g). a number multiple of 8.
- h). a two digit number divisible by 5.
- i). a two digit number divisible by 2.
- j). a two digit number divisible by 3.
- k). a two digit number divisible by 4.
- l). a two digit number perfect square.
- m). a perfect cube number.
- n). a prime number.
- o). neither divisible by 5 nor 10.
- p). neither divisible by 2 nor 5.
- q). neither divisible by 3 nor 5.
- r). a two digit prime number.
- s). an even prime number.
- t). a number is not divisible by 5.
- u). a number is not divisible by 3.
- v). a number is not divisible by 2 and 3.

7. A box contains 19 balls bearing numbers 1,2,3, 19 respectively. A ball is drawn at random from the box, Find the probability that the number on the ball is

- a). a two-digit number
- b). a perfect square number
- c). a number divisible by 5.
- d). a number divisible by 2 or 3.
- e). a number divisible by 2 and 3.
- f). a number divisible by 7.
- g). a number multiple of 8.
- h). a two digit number divisible by 5.
- i). a two digit number divisible by 2.
- j). a two digit number divisible by 3.
- k). a two digit number divisible by 4.
- l). a two digit number perfect square.
- m). a perfect cube number.
- n). a prime number.
- o). neither divisible by 5 nor 10.
- p). neither divisible by 2 nor 5.
- q). neither divisible by 3 nor 5.
- r). a two digit prime number.
- s). an even prime number.

- t). a number is not divisible by 5.
- u). a number is not divisible by 3.
- v). a number is not divisible by 2 and 3.

8. A box contains 20 balls bearing numbers 1,2,3, 20 respectively. A ball is drawn at random from the box, Find the probability that the number on the ball is

- a). a two-digit number
- b). a perfect square number
- c). a number divisible by 5.
- d). a number divisible by 2 or 3.
- e). a number divisible by 2 and 3.
- f). a number divisible by 7.
- g). a number multiple of 8.
- h). a two digit number divisible by 5.
- i). a two digit number divisible by 2.
- j). a two digit number divisible by 3.
- k). a two digit number divisible by 4.
- l). a two digit number perfect square.
- m). a perfect cube number.
- n). a prime number.
- o). neither divisible by 5 nor 10.
- p). neither divisible by 2 nor 5.
- q). neither divisible by 3 nor 5.
- r). a two digit prime number.
- s). an even prime number.
- t). a number is not divisible by 5.
- u). a number is not divisible by 3.
- v). a number is not divisible by 2 and 3.

9. 15 cards numbered 1, 2, 3, 4,..... 14, 15 are put in a box and mixed thoroughly. A man draws a card at random from the box. Find the probability that the number on the card is

- a). a two-digit number
- b). a perfect square number
- c). a number divisible by 5.
- d). a number divisible by 2 or 3.
- e). a number divisible by 2 and 3.
- f). a number divisible by 7.
- g). a number multiple of 8.
- h). a two digit number divisible by 5.
- i). a two digit number divisible by 2.
- j). a two digit number divisible by 3.
- k). a two digit number divisible by 4.
- l). a two digit number perfect square.
- m). a perfect cube number.
- n). a prime number.
- o). neither divisible by 5 nor 10.
- p). neither divisible by 2 nor 5.
- q). neither divisible by 3 nor 5.
- r). a two digit prime number.
- s). an even prime number.
- t). a number is not divisible by 5.
- u). a number is not divisible by 3.
- v). a number is not divisible by 2 and 3.

- 10.** Tickets numbered 2, 3, 4, 5,100, 101 are placed in a box and mixed thoroughly. One ticket is drawn at random from the box. Find the probability that the number on the ticket is
- a). a two-digit number
 - b). a perfect square number
 - c). a number divisible by 5.
 - d). a number divisible by 2 or 3.
 - e). a number divisible by 2 and 3.
 - f). a number divisible by 7.
 - g). a number multiple of 8.
 - h). a two digit number divisible by 5.
 - i). a two digit number divisible by 2.
 - j). a two digit number divisible by 3.
 - k). a two digit number divisible by 4.
 - l). a two digit number perfect square.
 - m). a perfect cube number.
 - n). a prime number.
 - o). neither divisible by 5 nor 10.
 - p). neither divisible by 2 nor 5.
 - q). neither divisible by 3 nor 5.
 - r). a two digit prime number.
 - s). an even prime number.
 - t). a number is not divisible by 5.
 - u). a number is not divisible by 3.
 - v). a number is not divisible by 2 and 3.
- 11.** Cards are marked with numbers 5, 6, 7,50 are placed in the box and mixed thoroughly. One card is drawn at random from the box. What is the probability of getting
- a). a two-digit number
 - b). a perfect square number
 - c). a number divisible by 5.
 - d). a number divisible by 2 or 3.
 - e). a number divisible by 2 and 3.
 - f). a number divisible by 7.
 - g). a number multiple of 8.
 - h). a two digit number divisible by 5.
 - i). a two digit number divisible by 2.
 - j). a two digit number divisible by 3.
 - k). a two digit number divisible by 4.
 - l). a two digit number perfect square.
 - m). a perfect cube number.
 - n). a prime number.
 - o). neither divisible by 5 nor 10.
 - p). neither divisible by 2 nor 5.
 - q). neither divisible by 3 nor 5.
 - r). a two digit prime number.
 - s). an even prime number.
 - t). a number is not divisible by 5.
 - u). a number is not divisible by 3.
 - v). a number is not divisible by 2 and 3.
-

PRACTICE QUESTIONS
CLASS X : CHAPTER – 15
PROBABILITY
LOGICAL REASONING BASED QUESTIONS

1. Why is tossing a coin considered to be a fair way of deciding which team should get the ball at the beginning of a football game?
2. The probability that it will rain today is 0.84. What is the probability that it will not rain today?
3. What is the probability that an ordinary year has 53 Sundays?
4. Find the probability of getting 53 Fridays in a leap year.
5. Find the probability of getting 53 Fridays or 53 Saturdays in a leap year.
6. Find the probability of getting 53 Mondays or 53 Tuesday in an ordinary year.
7. Out of 400 bulbs in a box, 15 bulbs are defective. One bulb is taken out at random from the box. Find the probability that the drawn bulb is not defective.
8. In a lottery there are 10 prizes and 25 blanks. What is the probability of getting a prize?
9. 250 lottery tickets were sold and there are 5 prizes on these tickets. If Mahesh purchased one lottery ticket, what is the probability that he wins a prize?
10. The record of a weather station shows that out of the past 250 consecutive days, its weather forecasts were correct 175 times. (i) What is the probability that on a given day it was correct?
(ii) What is the probability that it was not correct on a given day?
11. A lot consists of 144 ball pens of which 20 are defective and the others are good. Nuri will buy a pen if it is good, but will not buy if it is defective. The shopkeeper draws one pen at random and gives it to her. What is the probability that (i) She will buy it ? (ii) She will not buy it ?
12. A box contains 5 red marbles, 8 white marbles and 4 green marbles. One marble is taken out of the box at random. What is the probability that the marble taken out will be (i) red ? (ii) white ?
(iii) not green?
13. Savita and Hamida are friends. What is the probability that both will have (i) different birthdays?
(ii) the same birthday? (ignoring a leap year).
14. 12 defective pens are accidentally mixed with 132 good ones. It is not possible to just look at a pen and tell whether or not it is defective. One pen is taken out at random from this lot. Determine the probability that the pen taken out is a good one.
15. A piggy bank contains hundred 50p coins, fifty Re 1 coins, twenty Rs 2 coins and ten Rs 5 coins. If it is equally likely that one of the coins will fall out when the bank is turned upside down, what is the probability that the coin (i) will be a 50 p coin ? (ii) will not be a Rs 5 coin?
16. Gopi buys a fish from a shop for his aquarium. The shopkeeper takes out one fish at random from a tank containing 5 male fish and 8 female fish. What is the probability that the fish taken out is a male fish?

17. A number x is selected from the numbers 1, 2, 3 and then a second number y is randomly selected from the number 1, 4, 9. What is the probability that the product xy of the two numbers will be less than 9?
18. A missing helicopter is reported to have crashed somewhere in the rectangular region shown in Fig. What is the probability that it crashed inside the lake shown in the figure?

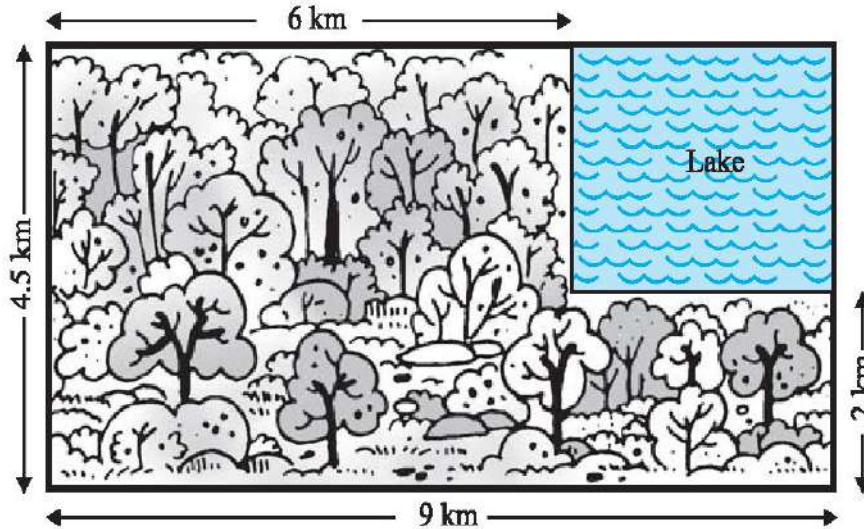

19. There are 40 students in Class X of a school of whom 25 are girls and 15 are boys. The class teacher has to select one student as a class representative. She writes the name of each student on a separate card, the cards being identical. Then she puts cards in a bag and stirs them thoroughly. She then draws one card from the bag. What is the probability that the name written on the card is the name of (i) a girl? (ii) a boy?
20. A carton consists of 100 shirts of which 88 are good, 8 have minor defects and 4 have major defects. Jimmy, a trader, will only accept the shirts which are good, but Sujatha, another trader, will only reject the shirts which have major defects. One shirt is drawn at random from the carton. What is the probability that (i) it is acceptable to Jimmy? (ii) it is acceptable to Sujatha?
21. Two customers Shyam and Ekta are visiting a particular shop in the same week (Tuesday to Saturday). Each is equally likely to visit the shop on any day as on another day. What is the probability that both will visit the shop on (i) the same day? (ii) consecutive days? (iii) different days?
22. Two customers are visiting a particular shop in the same week (Monday to Saturday). Each is equally likely to visit the shop on any day as on another day. What is the probability that both will visit the shop on (i) the same day? (ii) consecutive days? (iii) different days?
23. A bag contains 5 red balls and some blue balls. If the probability of drawing a blue ball is *double* that of a red ball, determine the number of blue balls in the bag.
24. A box contains 12 balls out of which x are black. If one ball is drawn at random from the box, what is the probability that it will be a black ball? If 6 more black balls are put in the box, the probability of drawing a black ball is now double of what it was before. Find x .
25. A jar contains 24 marbles, some are green and others are blue. If a marble is drawn at random from the jar, the probability that it is green is $\frac{2}{3}$. Find the number of blue marbles in the jar.

26. A lot consists of 144 ball pens of which 20 are defective and the others are good. Nuri will buy a pen if it is good, but will not buy if it is defective. The shopkeeper draws one pen at random and gives it to her. What is the probability that (i) She will buy it ? (ii) She will not buy it ?
27. A jar contains 54 marbles, each of which is blue, green or white. If a marble is drawn at random from the jar, the probability that it is green is $\frac{1}{3}$ and that of getting a blue marble is $\frac{4}{9}$. Find the number of white marbles in the jar.
28. A letter is chosen at random from the letters of the word 'ASSASSINATION'. Find the probability that the letter chosen is a (i) vowel (ii) consonant (iii) A (iv) S (v) N.
29. A letter is chosen at random from the letters of the word 'INDEPENDENCE'. Find the probability that the letter chosen is a (i) vowel (ii) consonant (iii) E (iv) N (v) D.
30. A letter is chosen at random from the letters of the word 'MATHEMATICS'. Find the probability that the letter chosen is a (i) vowel (ii) consonant (iii) A (iv) T (v) M.
31. A letter of English alphabets is chosen at random. Determine the probability that the letter is a consonant.
32. There are 1000 sealed envelopes in a box, 10 of them contain a cash prize of Rs 100 each, 100 of them contain a cash prize of Rs 50 each and 200 of them contain a cash prize of Rs 10 each and rest do not contain any cash prize. If they are well shuffled and an envelope is picked up out, what is the probability that it contains no cash prize?
33. Box A contains 25 slips of which 19 are marked Re 1 and other are marked Rs 5 each. Box B contains 50 slips of which 45 are marked Re 1 each and others are marked Rs 13 each. Slips of both boxes are poured into a third box and reshuffled. A slip is drawn at random. What is the probability that it is marked other than Re 1?
34. A carton of 24 bulbs contain 6 defective bulbs. One bulbs is drawn at random. What is the probability that the bulb is not defective? If the bulb selected is defective and it is not replaced and a second bulb is selected at random from the rest, what is the probability that the second bulb is defective?
35. A child's game has 8 triangles of which 3 are blue and rest are red, and 10 squares of which 6 are blue and rest are red. One piece is lost at random. Find the probability that it is a (i) triangle (ii) square (iii) square of blue colour (iv) triangle of red colour
36. In a game, the entry fee is Rs 5. The game consists of a tossing a coin 3 times. If one or two heads show, Sweta gets her entry fee back. If she throws 3 heads, she receives double the entry fees. Otherwise she will lose. For tossing a coin three times, find the probability that she (i) loses the entry fee. (ii) gets double entry fee. (iii) just gets her entry fee.
37. A die has its six faces marked 0, 1, 1, 1, 6, 6. Two such dice are thrown together and the total score is recorded. (i) How many different scores are possible? (ii) What is the probability of getting a total of 7?
38. A lot consists of 48 mobile phones of which 42 are good, 3 have only minor defects and 3 have major defects. Varnika will buy a phone if it is good but the trader will only buy a mobile if it has no major defect. One phone is selected at random from the lot. What is the probability that it is (i) a good phone (ii) a bad phone

39. (i) A lot of 20 bulbs contain 4 defective ones. One bulb is drawn at random from the lot. What is the probability that this bulb is defective?
(ii) Suppose the bulb drawn in (i) is not defective and is not replaced. Now one bulb is drawn at random from the rest. What is the probability that this bulb is not defective ?
40. A game of chance consists of spinning an arrow which comes to rest pointing at one of the numbers 1, 2, 3, 4, 5, 6, 7, 8 (see Fig.), and these are equally likely outcomes. What is the probability that it will point at (i) 8 ? (ii) an odd number? (iii) a number greater than 2? (iv) a number less than 9?

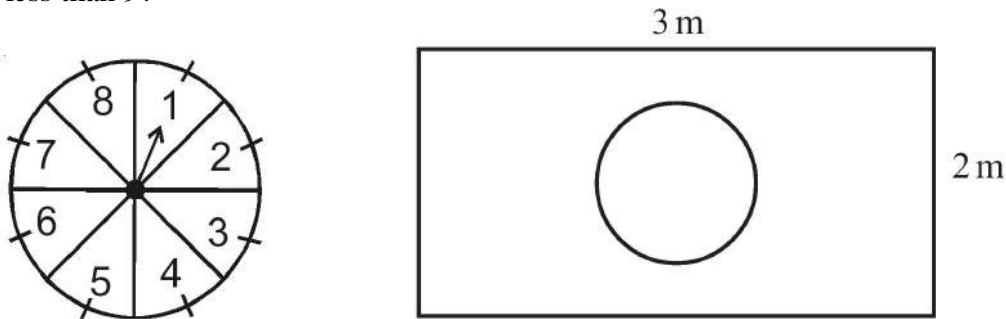

41. Suppose you drop a die at random on the rectangular region shown in above right-sided figure. What is the probability that it will land inside the circle with diameter 1m?
42. A child has a die whose six faces show the letters as given below:
A B C D E A
- The die is thrown once. What is the probability of getting (i) A? (ii) D?
43. A game consists of tossing a one rupee coin 3 times and noting its outcome each time. Hanif wins if all the tosses give the same result i.e., three heads or three tails, and loses otherwise. Calculate the probability that Hanif will lose the game.